

MRXBOX95-WH1-1Z & MRXBOX95AB-WH1-1Z

Both the MRXBOX95-WH1-1Z and MRXBOX95AB-WH1-1Z are designed to provide optimised balanced (supply and extract) mechanical ventilation heat recovery, whilst offering the best all-in-one acoustic solution on the market.

Tempered air is delivered into 'living areas' whilst extracting moisture laden air from 'wet areas', creating comfortable and well ventilated homes. The unit has the facility to commission the supply and extract fans independently on both minimum and maximum speeds, and the heat exchange block can recover up to 95% of the normally wasted heat that has been extracted from 'wet rooms'. The "1Z" element of the above product codes relates to our new Q-Aire all-in-one acoustic enclosure, designed specifically for our MRXBOX range of heat recovery units. It acts as an acoustic enclosure allowing the MVHR unit and attenuator to be entirely encased in an aesthetically pleasing model which encloses the attenuators and flexible duct connections that would otherwise be visible and unsightly, all whilst making significant reduction in case-radiated noise.

Please note both of these units are available in Opposite Handed format. EU Energy rating A+ as per EU regulation No. 1254/2014. Please contact our Sales Team for further details.



Typical Installation

Limited ceiling voids in modern apartments and complex duct arrangements coupled with increased airflow demands placed on MVHR systems in an effort to reduce the risk of overheating lead to higher system resistances and running speeds.

Restrictions on utility cupboard space, practical and financial limitations frequently prevent the construction of acoustic cupboards, whilst modern light-weight wall construction methods offer little mass to absorb unit noise and vibration. This can often result in the transfer of low frequency noise and vibration into adjacent living and sleeping areas.

These factors leave designers at risk of exceeding the stringent noise requirements specified in Part F of the building regulations and further defined by CIBSE.

By integrating the MVHR unit and flexible connections within an enclosure and supporting the internals on anti-vibration mounts, noise and vibration are isolated.

Performance - MRBOX95(AB)-WH1-1Z

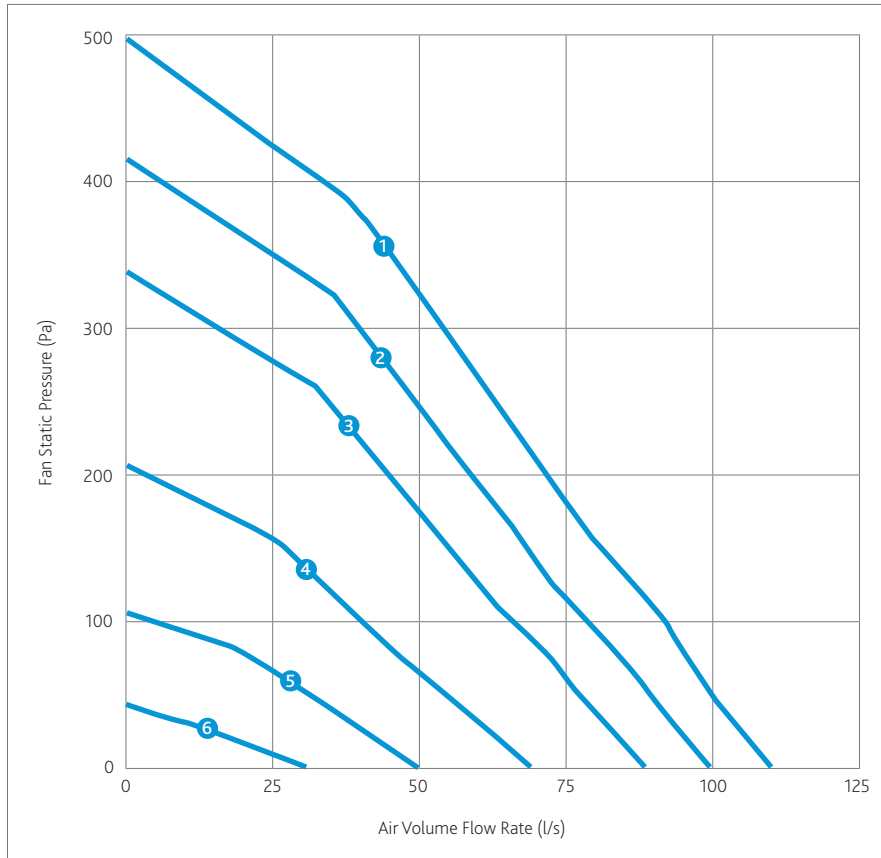

CODE DESCRIPTION

MRXBOX95-WH1-1Z



1. Multi-room supply and extract heat recovery
2. Product range
3. Efficiency
4. Wall/cupboard application
5. High Duty Model 1
6. Acoustic enclosure of MVHR unit plus Silencer

MRXBOX95AB-WH1-1Z



1. Multi-room supply and extract heat recovery
2. Product range
3. Efficiency
4. Automatic Summer Bypass
5. Wall/cupboard application
6. High Duty Model 1
7. Acoustic enclosure of MVHR unit plus Silencer

Electrical & Sound

WH1 Sound Data with 1Z fitted											
	Maximum power consumption	Frequency/Hz	63	125	250	500	1K	2K	4K	8K	dBA @3m
Curve	W	Sound Power Levels dB re 1pW									
1	150	Open Inlet	40	41	43	33	25	<16	<16	<16	28
		Open Outlet	42	53	56	53	39	34	30	26	
		Breakout	51	59	51	38	19	<16	<16	<16	
2	114	Open Inlet	40	40	42	32	23	<16	<16	<16	27
		Open Outlet	42	52	55	52	37	32	28	24	
		Breakout	51	58	50	37	17	<16	<16	<16	
3	75	Open Inlet	39	40	41	30	21	<16	<16	<16	27
		Open Outlet	41	52	54	50	35	30	26	22	
		Breakout	50	58	49	35	15	<16	<16	<16	
4	36	Open Inlet	38	38	38	27	<16	<16	<16	<16	25
		Open Outlet	40	50	51	47	29	24	20	<16	
		Breakout	49	56	46	32	<16	<16	<16	<16	
5	14	Open Inlet	36	35	35	22	8	<16	<16	<16	21
		Open Outlet	38	47	48	42	22	17	<16	<16	
		Breakout	47	53	43	27	<16	<16	<16	<16	
6	8	Open Inlet	33	32	29	14	<16	<16	<16	<16	18
		Open Outlet	35	44	42	34	<16	<16	<16	<16	
		Breakout	44	50	37	19	<16	<16	<16	<16	
WH1 Sound Data with 1Z & DB fitted											
1	150	Open Inlet	40	34	38	28	18	<16	<16	<16	28
		Open Outlet	38	48	50	43	30	24	23	<16	
		Breakout	51	59	51	38	19	<16	<16	<16	

The maximum power consumption shown above (Watts) is consumed on units running continuously, not taking into account any heat recovery saving and based on SAP Appendix Q testing. The breakout case-radiated dBA values are given for Hemispherical free field radiation at 3m – to obtain the spherical radiated data, subtract 3dBA.

Sap Appendix Q Test Results

Product Code	MRXBOX95AB-WH1-1Z			MRXBOX95-WH1-1Z		
SAP Identifier	MRXBOX95AB-WH1			MRXBOX95-WH1		
Application	Specific Fan Power (W/l/s)	Heat Exchange Efficiency	Energy Saving Trust Best Practice Compliant	Specific Fan Power (W/l/s)	Heat Exchange Efficiency	Energy Saving Trust Best Practice Compliant
Kitchen + 1 Wet Room	0.52	88%	Yes	0.42	91%	Yes
Kitchen + 2 Wet Room	0.56	88%	Yes	0.50	91%	Yes
Kitchen + 3 Wet Room	0.67	88%	Yes	0.61	89%	Yes
Kitchen + 4 Wet Room	0.78	86%	Yes	0.75	88%	Yes
Kitchen + 5 Wet Room	0.95	86%	Yes	0.90	87%	Yes
Kitchen + 6 Wet Room	1.16	85%	Yes	1.05	85%	Yes
Kitchen + 7 Wet Room	1.40	85%	Yes	-	-	Yes

General Arrangement

STANDARD UNIT SPIGOT LOCATION & DUCTING REFERENCES

- Spigot 1. 150mm dia. = Extract air from dwelling
- Spigot 2. 150mm dia. = Exhaust air to outside
- Spigot 3. 150mm dia. = Intake air from outside
- Spigot 4. 150mm dia. = Supply air to property

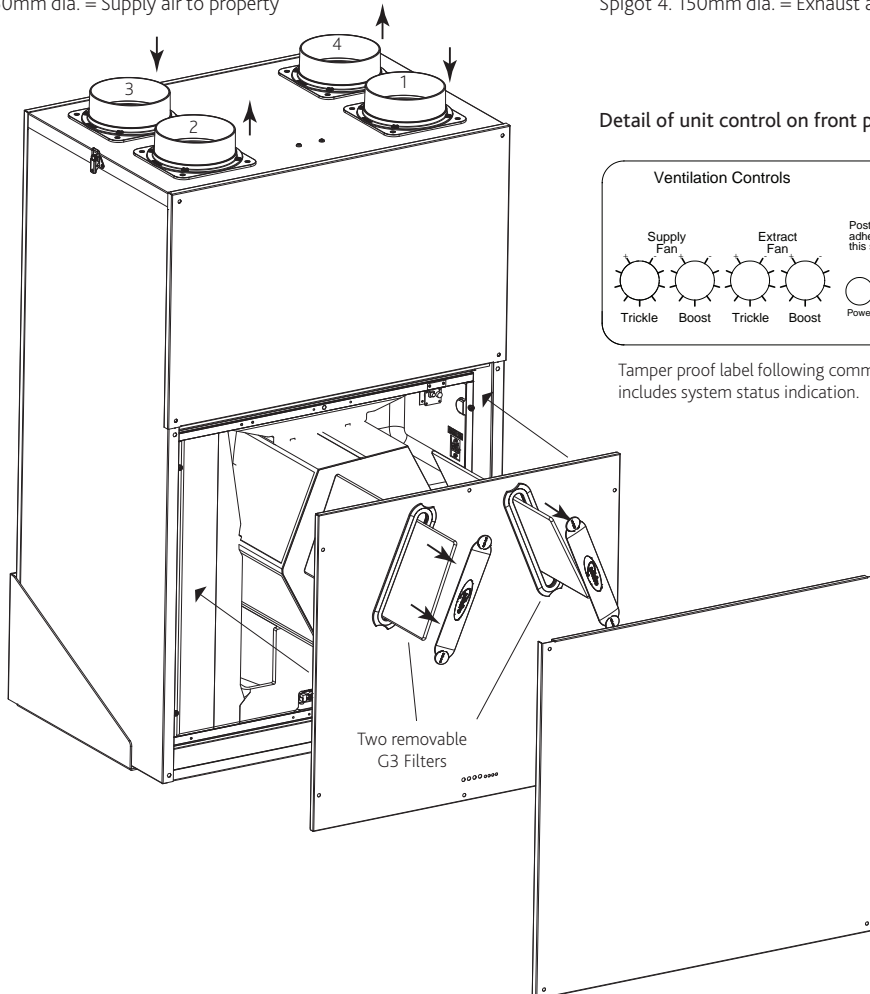

OPPOSITE HANDED UNIT SPIGOT LOCATION & DUCTING REFERENCES

- Spigot 1. 150mm dia. = Intake air from outside
- Spigot 2. 150mm dia. = Supply air to property
- Spigot 3. 150mm dia. = Extract air from dwelling
- Spigot 4. 150mm dia. = Exhaust air to outside

Detail of unit control on front panel.

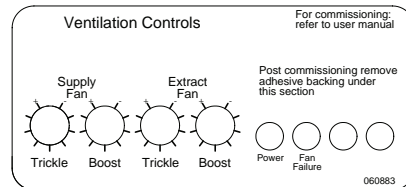

Tamper proof label following commissioning, includes system status indication.

Ancillaries

Distribution Box

The DB-WH1 is fitted on top of the MRXBOX95(AB)-WH1-1Z before installation and offers a neat arrangement by directly distributing the initial ducting. It further benefits this MVHR system by reducing any in-line noise breakout, therefore improving this acoustic solution.

*For the DB-WH1 acoustic data please refer to the bottom 3 lines of the table found on pg 39.

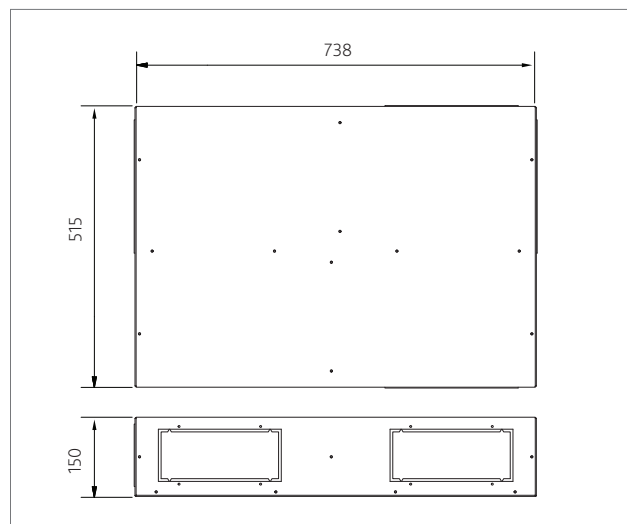
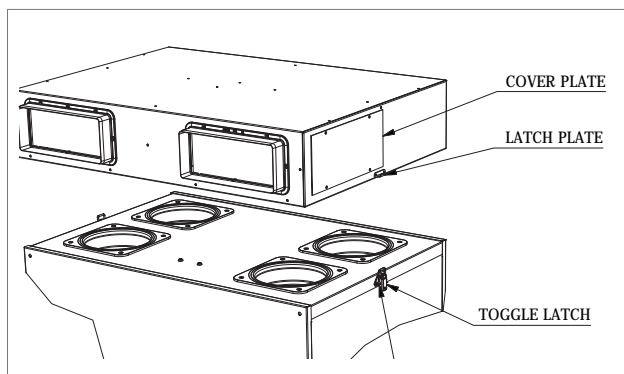
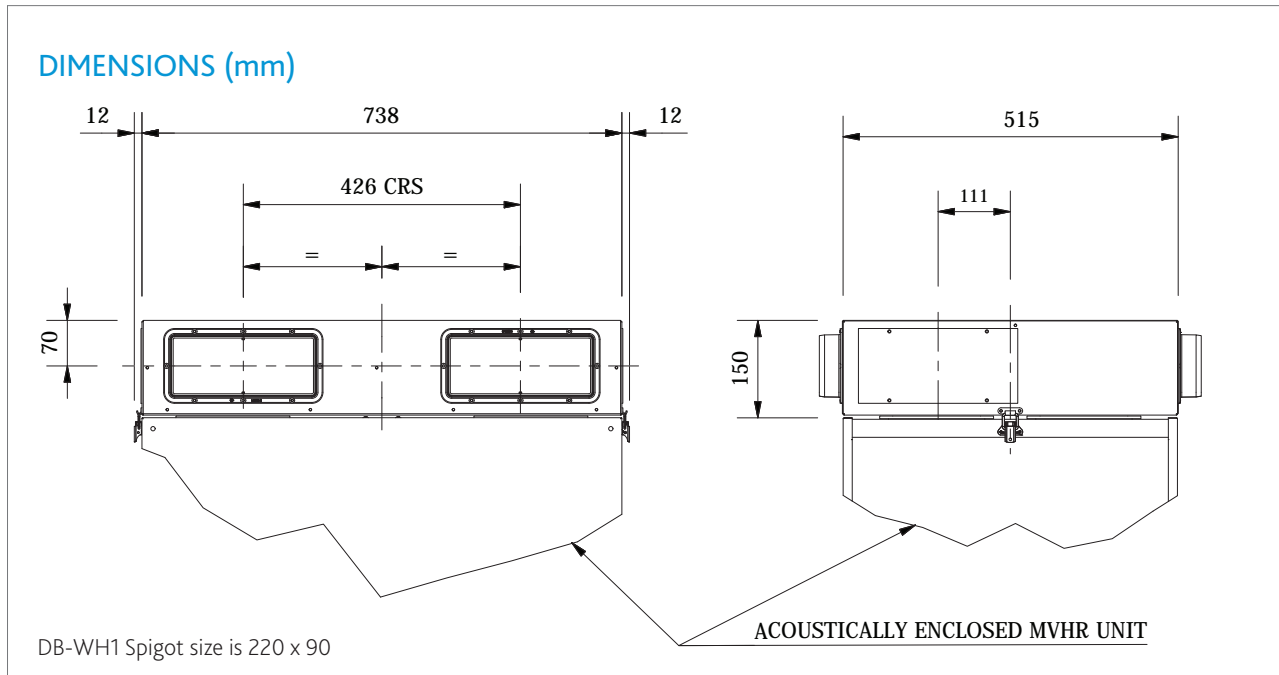

Humidity Sensor

A low voltage sensor which activates the MVHR system when the relative humidity level exceeds a set point. The MRXBOX95-HUM incorporates an overrun timer and allows the user to manually adjust the relative humidity set point.



Remote Fail Indicator

The MRXBOX95-RFI flashes warning light when fan failure occurs. This remote device will ensure you are always aware of the status of the system.



MRXBOX95-PIR (passive infra-red)

A low voltage sensor, detects movement and activates system. Incorporates overrun timer and timer adjustments.



LCD Touchscreen Controller

Simple, intuitive and discreet the Nuair LCD control- MRXBOX-VSC – puts you in total control of your MVHR system. With a wide range of functions and settings, no other product gives you the freedom to tailor performance whilst saving energy.

DIMENSIONS (mm)

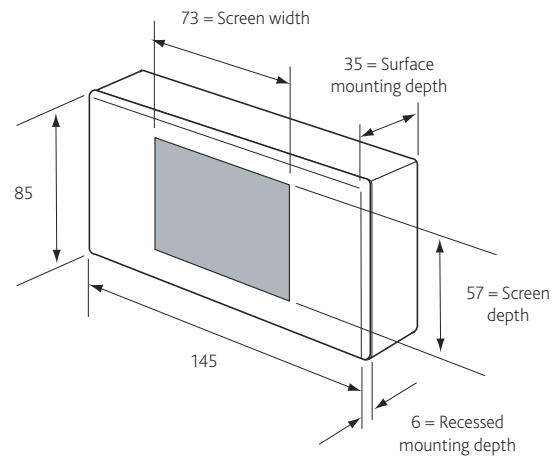

MRXBOX-VSC
CONTROL SCREEN
COMPATIBLE WITH
THIS UNIT

Technical - MRBOX95(AB)-WH1-1Z

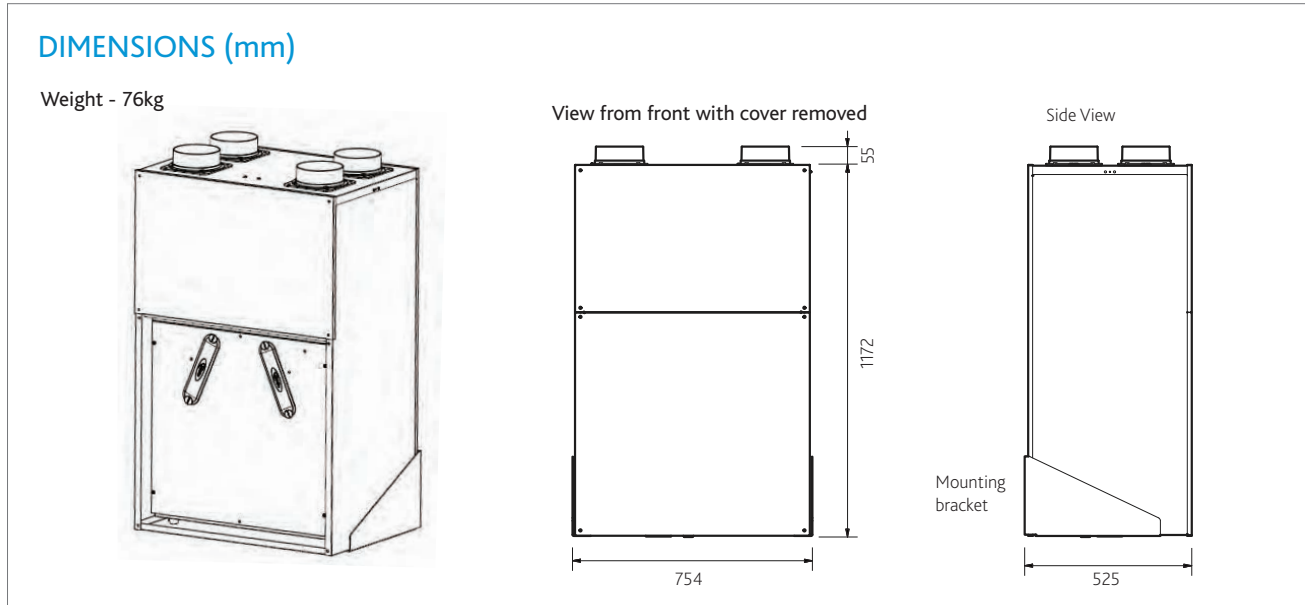

Wiring - MRBOX95(AB)-WH1-1Z

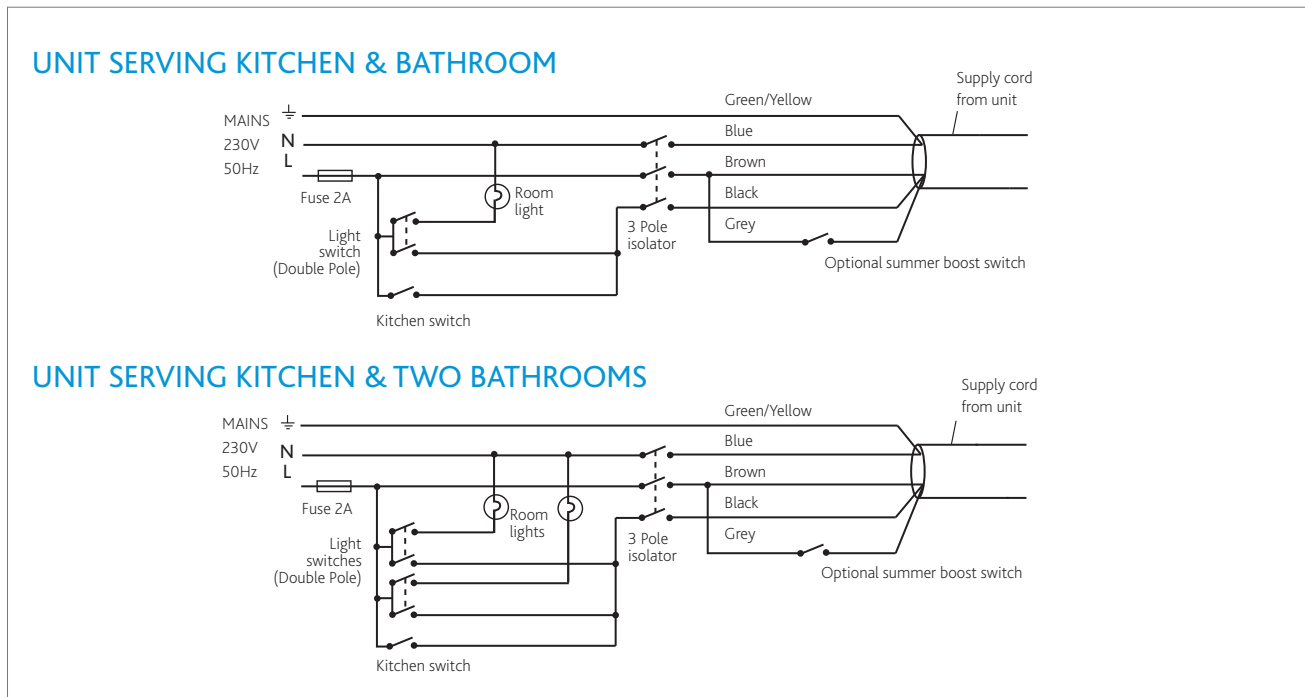

Electrical Details

Please note: the electrical connection of the unit must be carried out by a qualified electrician.

The unit is supplied with a flexible cord for connection to the mains supply.

NOTE: This unit must be earthed.

The mains power supply cable should be connected to a fixed wiring installation, via a fused isolator, in accordance with current IEE wiring regulations.

ELECTRICAL DETAILS: MRXBOX95-WH1-1Z	
Voltage:	230V 1ph 50Hz
Consumption:	WH1 - 1.3 Amp
Fuse rating:	3 Amp

Consultants Specification

TECHNICAL DATA

Fan Codes: MRXBOX95AB-WH1-1Z / MRXBOX95-WH1-1Z / MRXBOX95AB-WH1-1Z-OH / MRXBOX95-WH1-1Z-OH

Acoustically Enclosed Wall Mounted Multi-room Heat Recovery unit.

SPECIFICATION

The unit shall be fully insulated providing excellent thermal and acoustic characteristics and shall be complete with a multi plate counter flow high efficiency heat exchanger block, with a thermal efficiency of up to 95%. The heat exchanger shall be protected by G3 grade filters on fresh air inlet and system extract. The heat exchanger and filters shall be accessible via the front access panel, enabling quick and easy maintenance.

The unit shall have low energy, high efficiency EC fan/motor assemblies with sealed for life bearings, the impellers shall be backward curved centrifugal type. The motors shall be suitable of an ambient temperature of 40°C.

The unit shall be supplied complete with a condensate drip tray and 21.5mm drain connection.

The unit shall be suitable for 150mm diameter circular ducting.

The breakout noise level and power requirements shall be as detailed by the unit manufacturer and in accordance with the ventilation equipment schedule.

Units shall be one of MRXBOX95AB-WH1-1Z, MRXBOX95-WH1-1Z, MRXBOX95AB-WH1-1Z-OH, MRXBOX95-WH1-1Z-OH as manufactured by Nuair.

The unit shall be provided within a white pre-painted or coated steel acoustic enclosure lined with a minimum of 20mm class '0' acoustic foam insulation to reduce breakout noise.

In-duct noise shall be attenuated on Intake/Exhaust/Supply/Extract by means of a 4-way attenuator mounted within the enclosure and close coupled directly to the unit. Flexible duct connections shall be within the enclosure, pre-fitted between the attenuator section and the connection spigots on the top face of the enclosure. (Removing the need for flexible duct connectors outside of the unit which may cause breakout).

The MVHR unit and attenuator assembly shall be retained within the enclosure on a metal tray supported on turret type anti-vibration mounts of suitable deflection to ensure that vibration is not transmitted to the supporting structure.

All operational components of the MVHR unit shall be accessible via the front panel of the enclosure. The enclosure shall be supported on 3mm (minimum) prefabricated steel cantilever wall brackets or other suitable fabricated steel supporting frame.

The unit shall be offered with a 5 year warranty.

The unit complies with EU regulations No.1253/2014 and No.1254/2014.

OPERATION

The supply and extract ventilation unit shall be positioned as indicated on the drawings and shall be in accordance with the particular fan schedule in the specification. This unit is also available in Opposite Hand formatting.

The combined supply and extract with heat recovery unit, shall supply filtered fresh air to each of the habitable rooms and vitiated air shall be extracted from the wet areas e.g. bathroom, en-suite, w.c, kitchen, utility rooms, etc. The supply air shall be pre-heated by the warm extract air via the integrated counter-flow heat exchanger element. The extracted air shall also be filtered before it reaches the heat exchanger block.

The ventilation unit shall vary its speed and therefore the ventilation rate, as it receives signals from the switched live signal from light/remote switches or any ancillary sensors. When signals are received, the fan shall alter its speed to adjustable, normal and boost rates.

The unit shall have the facility to commission the supply and extract fans independently on minimum speed (continuous background ventilation), and boost speed, via inbuilt minimum and maximum speed adjustment. The fans shall have infinitely variable speed control.

INTEGRAL AUTOMATIC SUMMER BYPASS (MRXBOX95AB-WH1-1Z & MRXBOX95AB-WH1-1Z-OH only)

Including Automatic SUMMER BYPASS where intake and return air temperatures shall be measured so that supply air temperatures can be maximised during winter months and minimised as external ambient temperature rises. The Summer Bypass damper shall be opened by a wax actuator. Supply and Extract air shall be filtered irrespective of the bypass setting (open or closed).

Integral Humidity Sensor

The integral humidity sensor incorporated within the extract fan chamber will automatically boost both the extract and supply fan, to the commissioned boost speed, when the humidity level exceeds that set by the front panel mounted adjustment potentiometer.

CONTROL OPTIONS

All versions shall have the following functions integrally mounted within the fan unit on a purpose made PCB, all such components pre-wired and factory fitted by the manufacturer:

- Independent control of background supply and extract flow rates.
- Independent control of boost speed supply and extract flow rates.
- Integral fan failure indication.
- Integral S/L terminal for boost from remote switch, e.g. light switch, kitchen boost switch.
- Integral heat exchanger frost protection.
- Discreet daily run monitor.
- Integral humidistat.

OPTIONAL CONTROLS

MRXBOX95-RFI Remote fail indicator.
(or Volt Free contacts to allow failure indication to BMS).

MRXBOX95-PIR (Passive Infra Red)
A low voltage sensor which detects movement and activates system. Incorporates overrun timer and timer adjustments.

MRBOX95-HUM
A low voltage sensor which activates the system when the relative humidity level is above a set point. Incorporates overrun timer and relative humidity set-point level adjustment.

MRXBOX-VSC
An LCD controller for MVHR system with a 3.2" touch screen display. Can be surface or semi-recess mounted.