

NALTM 50 & 60HZ

Metal Cased Centrifugal Fans Installation and Maintenance



CE The EMC Directive
2014/30/EU
The Low Voltage
Directive
2014/35/EU

1.0 INTRODUCTION

The NALTM unit is supplied with a pre-wired terminal box and an IP44 rated, class B (unit sizes 100-160) or class F (unit sizes 200-315) insulated motor. The fans are designed to convey clean air with a maximum temperature of up to 60°C (NALTM-315H up to 55°C only).

Do not operate the fan in the presence of inflammable vapours (alcohol etc). An adequate supply of fresh air must be provided if the fan is to be fitted in a room with a gas burning appliance which is not of the balance flue type.

Figure 1. Unit Drawing

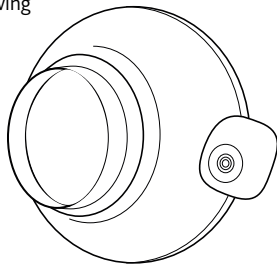

Code Description:

NALTM-100H
| | |
1 2 3

1. NALTM - Centrifugal Metal Tube Fan Range
2. 100 - Case Size
3. No Suffix - 50Hz 230V
H - 60Hz 220V

2.0 HANDLING

Always handle the fans carefully to avoid damage and distortion. Care should be taken to ensure that any slings used for lifting purposes do not damage the casing, connection box, impeller or inlet cone.

3.0 INSTALLATION

Installation must be carried out by a competent person in accordance with the appropriate authority and conforming to all statutory and governing regulations (e.g. IEE, CIBSE etc.).

From the fan Rating Plate, observe the weight of the unit and select the mounting position and structure that can support the unit.

These are not for stand-alone use. They are designed to be incorporated into ducted systems, machines or where safe (i.e. operation has been ensured by providing applicable protection to moving parts).

This unit is not designed for external use. Before installing ensure the impeller is running freely and there are no obstructions to the airflow

A robust mounting foot is available as an accessory, to ease installation.

IMPORTANT

For good EMC engineering practice, any sensor cables or switched live cables should not be placed within 50mm of other cables or on the same metal cable tray as other cables.

Isolation - Before commencing work, make sure that the unit, switched live and any controls are electrically isolated from the mains supply.

Please note that this product must be earthed.

4.0 DIMENSIONS (mm) & Weights (kg)

Figure 2. Unit Dimensions

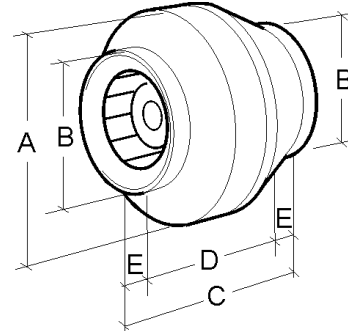

50 Hz Code	60 Hz Code	A	B	C	D	E	Weight
NALTM-100	NALTM-100H	241	98	196	150	23	3
NALTM-125	NALTM-125H	241	123	198	144	27	3
NALTM-150	NALTM-150H	332	147	212	166	23	5
NALTM-160	NALTM-160H	332	157	221	175	23	5
NALTM-200	NALTM-200H	333	198	223	173	25	5
NALTM-250	NALTM-250H	333	248	206	152	27	6
NALTM-315	NALTM-315H	401	312	230	180	25	8

5.0 ELECTRICAL WIRING

Electrically isolate unit before commencing any work. Ensure that the voltage and frequency of the electrical supply match the information stated on the Rating Plate on the unit. Wire the unit as shown in the wiring diagram. On connecting the electrical supply, ensure that the airflow direction corresponds with the direction of the airflow arrow sited on the unit.

Figure 3. Wiring diagram

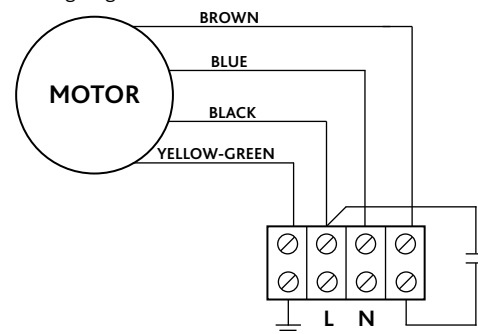

Electrical Note: Because the run and start currents depend upon the duty and associated duct work of an individual unit, the values quoted in the table are nominal.

Run currents will be exceeded if the unit is operated beyond the operating curve shown in the performance catalogue.

6.0 MAINTENANCE

Electrically isolate unit before commencing any work. Usage and conditions will dictate frequency of maintenance. We recommend a thorough inspection and cleaning three months after commissioning and, dependant on how the fan is found at least annually thereafter.

Fans and systems should be maintained in accordance with the HVCA Standard Maintenance Recommendations for Mechanical Services in Buildings Volume 11 Ventilation and Air-conditioning.

Do not use a high pressure cleaner (steam jet) or any solvents for cleaning purposes.

Do not immerse the unit in water.

Check all parts for security and general condition.

Ensure the impeller rotates freely.

7.0 WARRANTY

The unit has a one year warranty. The warranty starts from the date of delivery and covers faulty materials or workmanship and includes parts and labour.

This warranty is void if the equipment is modified without authorisation, is incorrectly applied, misused, disassembled, or not installed, commissioned and maintained in accordance with the details contained in this manual and general good practice.

The product warranty applies to the UK mainland and in accordance with Clause 14 of our Conditions of Sale. Customers purchasing from outside of the UK should contact Nuaire International Sales office for further details.

8.0 AFTER SALES ENQUIRIES

For technical assistance or further product information, including spare parts and replacement components, please contact the After Sales Department.

Telephone: 02920 858 400