



Opus 40,60 & 95

230V Surface and Recessed Mounted
Domestic Single & Twin fans

Installation and Maintenance

CE The EMC Directive
2014/30/EU
The Low Voltage
directive
2014/35/EU



Opus Fans

The Nuair range of Opus 230V fans have been specifically designed to ventilate areas such as the bathroom, toilet, stores, drying rooms, cupboards etc.

The range consists of three duty ranges, 40l/s, 60l/s and 95l/s. The 40 and 60 models are available as single and twin fan variants (twin fans are duty sharing). The 95 model is dual fan only (both fans run simultaneously).

The unit package is supplied to offer the installer 3 alternative mounting options.

Fig 1. Surface mounting with rear spigot.

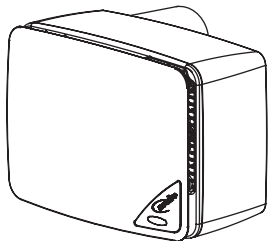

Fig. 2 Recessed Mounting top spigot (Not suitable for Opus 95D units).

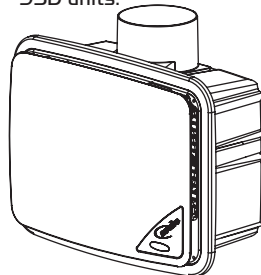
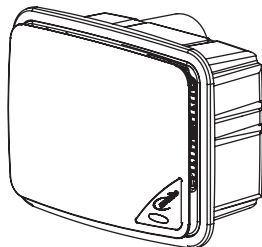

Fig. 3 Recessed mounting with rear spigot.



The unit discharges air through a 100mm dia.spigot which for surface mounted units exits at the rear of the unit, and for recessed mounting can discharge either through the rear or top of the unit (Fig 3).

Air entering the unit passes through the front grille, which can be fitted with an optional foam or metallic filter.

The motor(s) are 24V brushless DC. Bearings are sealed, self-lubricating ball type with integral locked rotor protection.

The fan/motor assembly can be fitted in one of two positions (fig 5 & 8). This is held in place by the yellow fastener located at the rear of the unit.

I.O Fan Installation General

Installation must be completed by competent persons, in accordance with good industry practice and should conform to all governing and statutory bodies i.e. IEE, CIBSE etc.

A solid non reverberant mounting position must be selected and passages for ductwork from the outlet spigot, as well as electrical connection prepared.

In addition compatible ductwork has already been installed.

Unpack the fan unit and other components and ensuring all parts are included against the components checklist below.

Key to fan components

- | | |
|--|--|
| 1. Fan unit front cover/grill (Part no. 040913/912). | 6. Rear spigot blank not shown see fig. 8 (Part no. 040917). |
| 2. Outer casing (Part no. 040915). | 7. Circular top spigot option (Part no. 040918). |
| 3. Inner casing. (Part no. 040914). | 8. Top spigot blank. (Part no. 040921). |
| 4. Recess flange option (Part no. 040919). | 9. Fan module. |
| 5. Circular rear spigot option. (Part no. 040954). | 10. Control. |
| | 11. Recessed frame mounting plate, see fig. 9. |
| | 12. Screw kit. |

Screw locations

Outer casing to Inner casing	4.2 x 9.5	(4 off)
Recess flange to Inner case	3.5 x 9.5	(4 off)
Rear spigot to Inner case	3.5 x 6.5	(2 off)
Rear spigot blank to Inner case	3.5 x 6.5	(2 off)
Grille section to Inner case	3.5 x 19	(4 off)

Fig. 4 General view of unit and components.

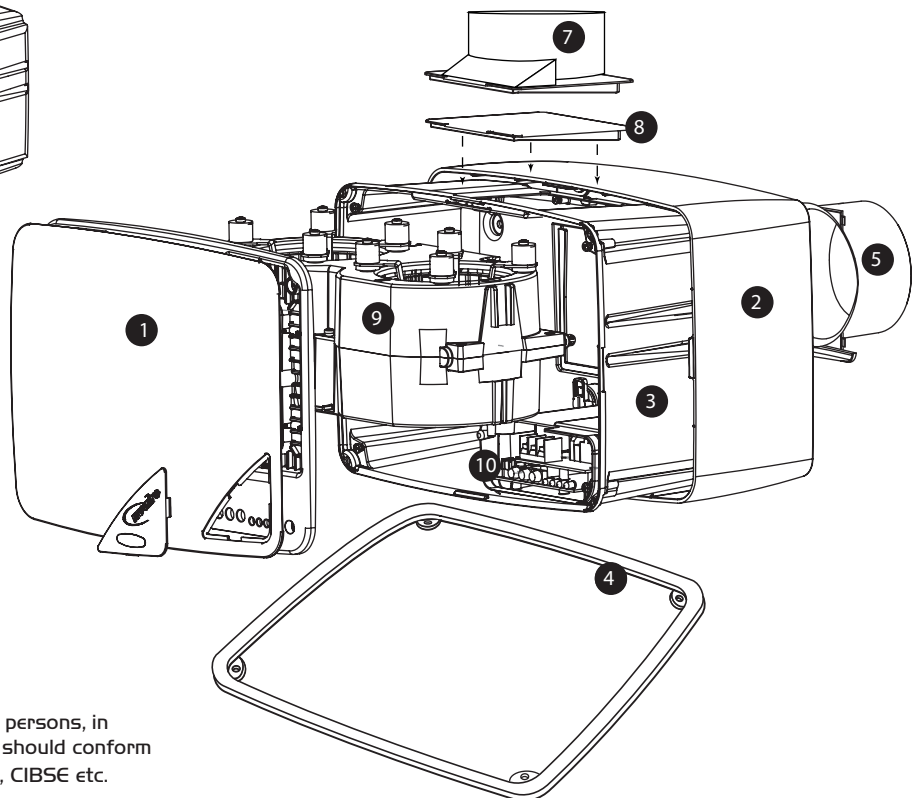
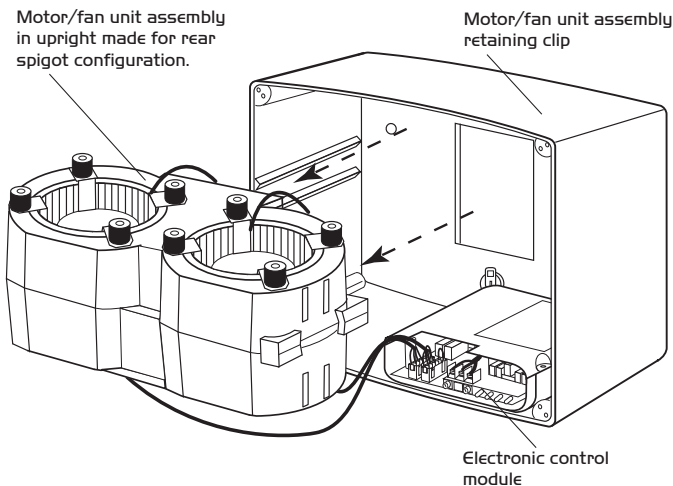

Fig. 5 View inside unit with components removed.



1.1 Fan Installation - Surface Mounted

1. Unpack the unit and components. Discard the top spigot (O40918), rear blank (O40917) and recess flange (O40919).

Fig. 6 Surface mounted in a cavity wall.

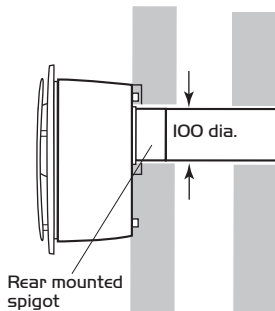

Remove the front cover/grille and disconnect the motors from the control circuit board, noting their orientation. Rotate the yellow retaining clip and remove the fan assembly. Leaving the control unit in place, remove the top section only.

2. Use the base as a template mark the discharge spigot and mounting holes onto the surface.
3. Core cut the hole for the spigot to 100mm dia.
4. Run suitable cable into the unit, noting the wiring should be for a fixed wired installation.

5. Run any ancillary wiring into the knockout "square".
6. Secure the case to the surface taking care not to twist or distort the case.
7. Connect all wiring (see 3.0) and re-fit top section of control unit. Re-fit fan assembly and connect motors to control board. Rotate yellow clip to lock in place.
8. Complete the installation by securing the front cover and fitting any filters. Test-run the unit.
9. Adjust control settings as required.

1.2 Recessed Mounting

For applications (Stud walls & ceilings) requiring top spigot configuration. (Not suitable for Opus 95D units).

Fig. 7 Recessed mounted in a stud wall.

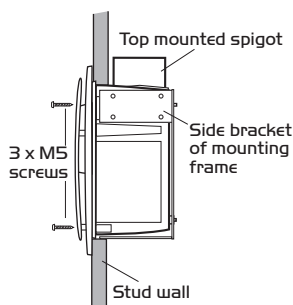

1. Unpack the unit and components. Discard the rear spigot (O40954), top spigot blank (O40921) and outer casing (O40915). Fit the recess flange (O40919) and rear spigot blank (O40917). Remove the front cover/grille and disconnect the motors from the control circuit board, noting their orientation. Rotate the yellow retaining clip and remove the fan assembly. Leaving the control unit in place, remove the top section only.

2. The unit should not be mounted directly to partition wall/ceiling but a suitable frame should be erected to secure the mounting frame kit to (fig.9).
3. Run suitable cable into the unit, noting the wiring should be for a fixed wired installation.
4. Run any ancillary wiring into the knockout "square".
5. Secure the case to the frame using the machine screws provided taking care not to twist or distort the case.
6. Connect all wiring (see 3.0) and re-fit top section of control unit. Re-fit fan assembly and connect motors to control board. Rotate yellow clip to lock in place.
7. Complete the installation by securing the front cover and fitting any filters. Test-run the unit.
8. Adjust control settings as required.

Fig. 8 Fan unit rotated for top spigot configuration. (Not suitable for Opus 95D units).

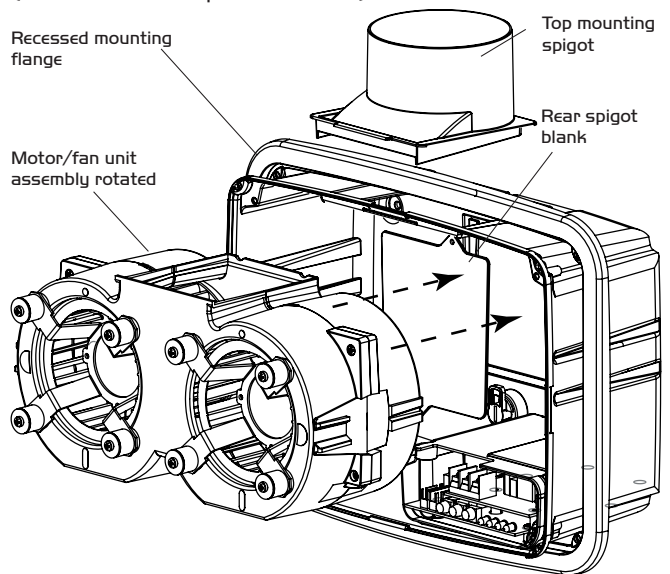
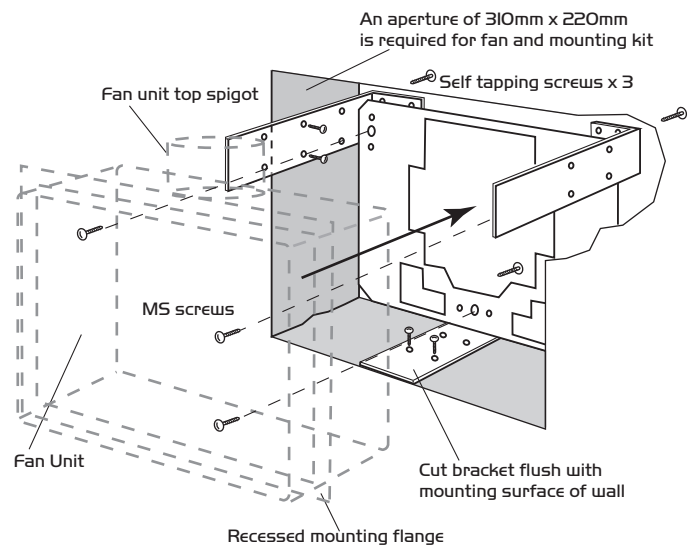

Fig. 9 Recessed mounting frame kit in wall aperture with top mounted spigot configuration.



IMPORTANT

Isolation - Before commencing work make sure that the unit, and Nuaire control are electrically isolated from the mains supply.

1.3 Recessed Mounting

For applications (Cavity walls) requiring rear spigot configuration.

Fig. 10 Recessed mounted in a cavity wall.

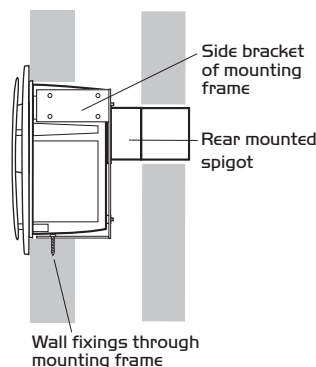

1. Unpack the unit and components. Discard the top spigot (040918), rear spigot blank (040915) and outer casing (040915). Fit the recess flange (040919) and rear spigot (040954). Remove the front cover/grille and disconnect the motors from the control circuit board, noting their orientation. Rotate the yellow retaining clip and remove the fan assembly. Leaving the control unit in place, remove the top section only.

2. The unit should not be mounted directly to partition wall/ceiling but a suitable frame should be erected to secure the mounting frame kit to (fig.11).

3. Run suitable cable into the unit, noting the wiring should be for a fixed wired installation.

4. Run any ancillary wiring into the knockout "square".

5. Secure the case to the frame using the machine screws provided taking care not to twist or distort the case.

6. Connect all wiring (see 3.0) and re-fit top section of control unit. Re-fit fan assembly and connect motors to control board. Rotate yellow clip to lock in place.

7. Complete the installation by securing the front cover and fitting any filters. Test-run the unit.

8. Adjust control settings as required.

Fig. 11 Recessed mounting frame kit in wall aperture with rear mounting spigot configuration.

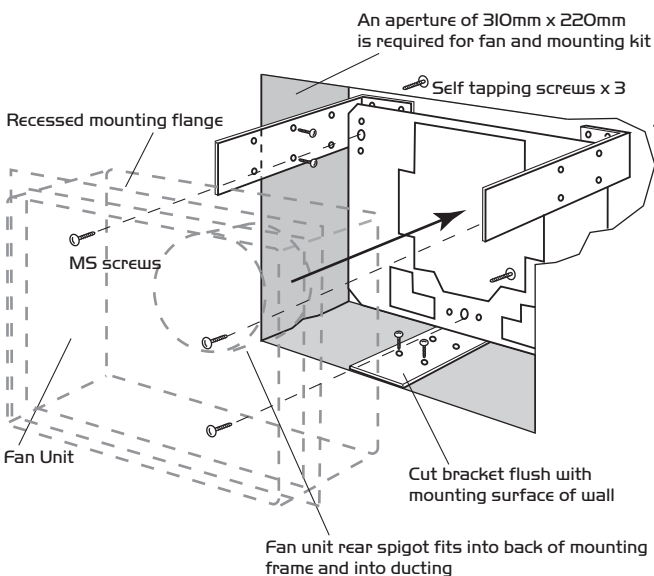

IMPORTANT

Isolation - Before commencing work make sure that the unit, and Nuair control are electrically isolated from the mains supply.

For good EMC engineering practice, any sensor cables or switched live cables should not be placed within 50mm of other cables or on the same metal cable tray as other cables.

2.0 Coding

Model	OPUS40-60-95 surface/recessed coding
Single Fan (basic on/off, with trickle switch)	S
Twin Fan (basic on/off, with trickle switch)	T
Dual Fan (2/3rds duty on fan failure)	D
Speed control (controls built in trickle & boost)	C
Ecosmart (speed control/sensors)	ES
Run on timer	R
PIR (run on timer included) only available on Ecosmart	P
Ancillaries	
Remote Fail Indicator	OPUS-RFI
Remote Fail Indicator for Ecosmart model only	OPUS-AVI
External Humidistat	HUMISEN
External Humidistat for Ecosmart model only	ES-HUMIDISTAT

3.0 Connections

Ecosmart control (see figure 11)

(a) Net

The IDC plug-in connectors are provided for the connection of compatible sensors, manual controls and for linking the fans together under a common control. If more than 3 connections are required, the junction box (product code ES-JB) should be used. NOTE: Do not run the SELV data cable in the same conduit as the mains cable and leave a 50mm separation with any power cables.

(b) Volt Free Relay Contacts

Note that the volt free contacts are not fused. If these are used to power any external equipment, the installer must provide adequate fusing or other protections. These contacts are rated at 5A resistive, 0.5A inductive.

(c) Run connections

These contacts are closed when the fan is running. Fault connections - No fault = the contacts are closed. Fault = the contacts are opened (this includes no power supply at the unit).

(d) Data Cable installation

A 4-core SELV data cable is used to connect devices such as sensors to the fan and for interconnecting multiple fan units. Do not run data cable in the same conduit as the mains cables and ensure there is a 50mm separation between the data cable and other cables. The maximum cable run between any two devices is 300m when it is installed in accordance with the instructions. Please note that the total data cable length used in any system must be less than 1000m. Keep the number of cable joints to a minimum to ensure the best data transmission efficiency between devices.

(e) Maximum number of devices

The maximum number of devices (including fans) that can be connected together via the cable is 32, irrespective of their functions.

(f) LED Indication

PWR GREEN: Power on and OK, RED: LED on when fan is not running.
 Standby Fan 1 GREEN: Fan 1 is running, RED: Fan 1 faulty.
 Fan 2 GREEN: Fan 2 is running, RED: Fan 2 faulty.

Basic Control

(a) Fault (terminal 2 and 3)

This should only be used with optional OPUS-RFI (remote fail indicator). Connecting mains or any other device will damage the control PCB.

(b) LED Indication

Fan 1 GREEN: Fan 1 is running, RED: Fan 1 faulty.
Fan 2 GREEN: Fan 2 is running, RED: Fan 2 faulty.

3.1 Wiring details Opus 40-60-95

Fig. 12 View inside electronic control module with cover removed.

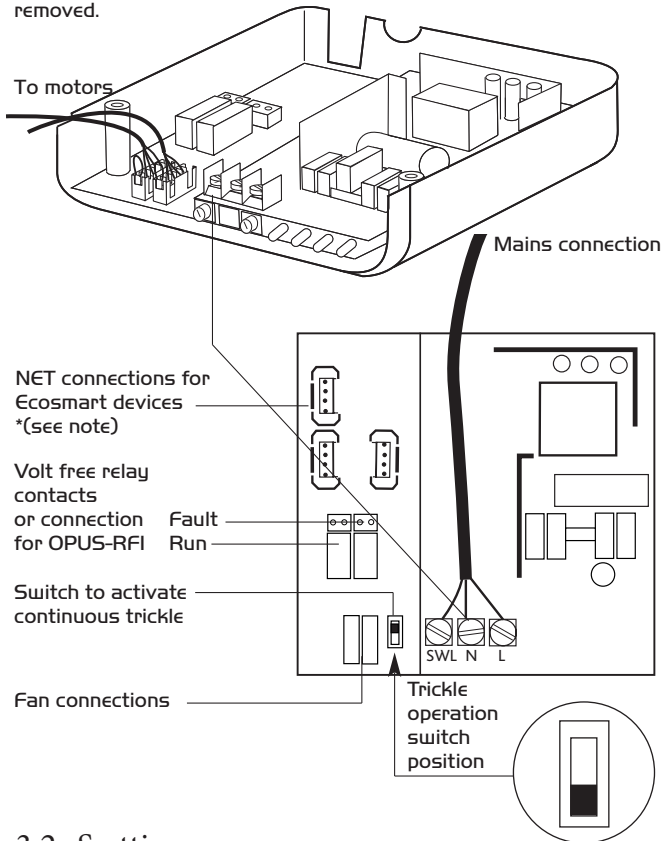

3.2 Settings

- Min speed – used to regulate trickle speed. Can be disabled using switch (Fig 12).
- Max speed – used to regulate full speed. Adjustable
- Run-on timer – between 1 and 60 minutes.

Fig. 13 Connection from electronic control module to the fan unit

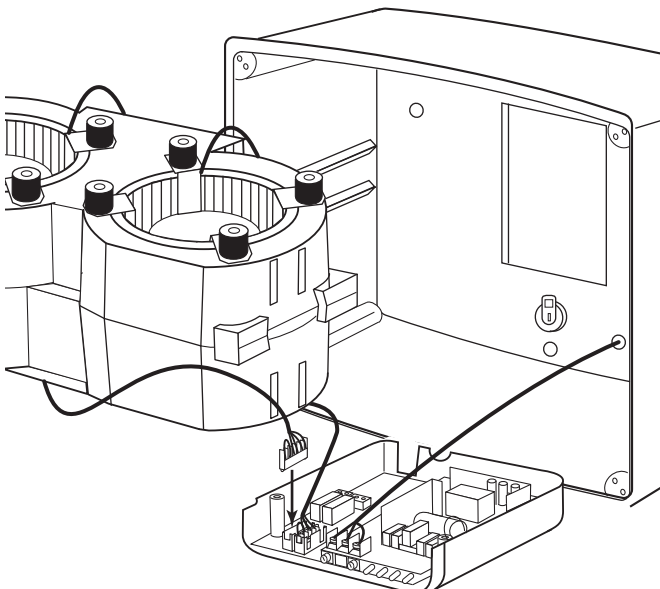

3.3 Wiring details Opus 40-60-95

Unit ventilating one room

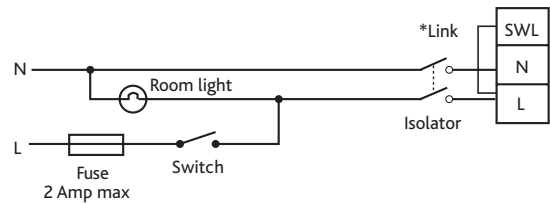

IMPORTANT

Note: Link also required when using Ecosmart speed controlling sensors. i.e. ES-TEMP, ES-RH, ES-UCF.

Unit ventilating one room using run on circuit and integral PIR, Humisen, ES-Humidistat

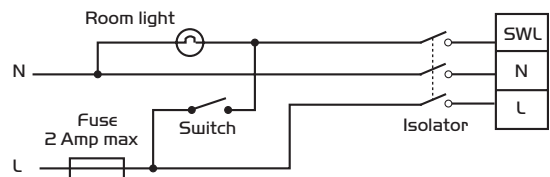

Power Consumption	Opus 40	Opus 60	Opus 95
Unit input power (watts)	14	43	72
Full load running current (amps)	0.11	0.32	0.6

4.0 Replacement of Parts

Should any component need replacing Nuair keep extensive stocks for quick delivery. When ordering spare parts, please quote the serial number of the unit and the ARC number of the purchase if possible (This information will be available on the fan label).

5.0 Warranty

The unit has a 3 year warranty. Ecosmart versions have a 5 year warranty. The warranty starts from the day of delivery and includes parts and labour for the first year. The remaining period covers replacement parts only.

This warranty is void if the equipment is modified without authorisation, is incorrectly applied, misused, disassembled, or not installed, commissioned and maintained in accordance with the details contained in this manual and general good practice.

The product warranty applies to the UK mainland and in accordance with Clause 14 of our Conditions of Sale. Customers purchasing from outside of the UK should contact Nuair International Sales office for further details.

6.0 After Sales Enquiries

For technical assistance or further product information, please contact the After Sales Department.

Telephone 02920 858 400

Technical or commercial considerations may, from time to time, make it necessary to alter the design, performance and dimensions of equipment and the right is reserved to make such changes without prior notice.

CE DECLARATION OF CONFORMITY

We declare that the machine named below conforms to the requirements of EC Council Directives relating to Electromagnetic Compatibility and Safety of Electrical Equipment.

Designation of machinery: Opus 230V Surface and Recessed Mounted Domestic Single and Twin fan with Ecosmart option.



Machinery Types: Opus 40, 60, 95 with suffix S or T followed by ES and/or other suffix.

Serial No.: As marked.

Relevant EC Council Directives: 2004/108/EC (EMC), 2006/95/EC (LVD) 2011/65/EU (RoHS Recast).

Applied Harmonised Standards: BS EN 61000-6-4:2007+A1: 2011, BS EN 50581:2012, BS EN 55014-1: 2006+A2:2011, BS EN 55014-2: 1997+A2:2008, BS EN 61000-3-2:2014, BS EN 61000-3-3:2013, BS EN 60335-2-80:2003+A2:2009.

Signature of manufacture representatives:

Name:	Position:	Date:
1) C. Biggs 	Technical Director	27.05.15
2) A. Jones 	Manufacturing Director	27.05.15

Basis of Self Attestation: Quality Assurance to BS EN ISO 9001 BSI Registered Firm Cert No. FM 149.

Nuairé Ltd,
Western Industrial Estate,
Caerphilly CF83 1NA.

DECLARATION OF INCORPORATION

We declare that the machinery named below is intended to be assembled with other components to constitute a system of machinery. All parts except for moving parts requiring the correct installation of safety guards comply with the essential requirements of the Machinery Directive. The machinery shall not be put into service until the system has been declared to be in conformity with the provisions of the EC Machinery Directive.

Designation of machinery: Opus 230V Surface and Recessed Mounted Domestic Single and Twin fan with Ecosmart option.



Machinery Types: Opus 40, 60, 95 with suffix S or T followed by ES and/or other suffix.

Serial No.: As marked.

Relevant EC Council Directives: 2006/42/EC (Machinery Directive).

Applied Harmonised Standards: EN ISO 12100:2010, EN ISO 13857:2008.

Signature of manufacture representatives:

Name:	Position:	Date:
1) C. Biggs 	Technical Director	27.05.15
2) A. Jones 	Manufacturing Director	27.05.15

Basis of Self Attestation: Quality Assurance to BS EN ISO 9001 BSI Registered Firm Cert No. FM 149.

Nuairé Ltd,
Western Industrial Estate,
Caerphilly CF83 1NA.

INFORMATION FOR SAFE INSTALLATION, OPERATION AND MAINTENANCE OF NUAIRE VENTILATION EQUIPMENT

To comply with EC Council Directives 2006/95/EC (Low Voltage Directive) and 2014/30/EU (EMC).

To be read in conjunction with the relevant Product Documentation (see 2.1)

1.0 GENERAL

1.1 The equipment referred to in this Declaration of Conformity and Incorporation is supplied by Nuairé to be assembled into a ventilation system which may or may not include additional components. The entire system must be considered for safety and EMC purposes and it is the responsibility of the installer to ensure that all of the equipment is installed in compliance with the manufacturers recommendations and with due regard to current legislation and codes of practice.

2.0 INFORMATION SUPPLIED WITH THE EQUIPMENT

2.1 Each item of equipment is supplied with a set of documentation which provides the information required for the safe installation and maintenance of the equipment. This may be in the form of a Data sheet and/or Installation and Maintenance instruction.

2.2 Each unit has a rating plate attached to its outer casing. The rating plate provides essential data relating to the equipment such as serial number, unit code and electrical data. Any further data that may be required will be found in the documentation. If any item is unclear or more information is required, contact Nuairé.

2.3 Where warning labels or notices are attached to the unit the instructions given must be adhered to.

3.0 TRANSPORTATION, HANDLING AND STORAGE

3.1 Care must be taken at all times to prevent damage to the equipment. Note that shock to the unit may result in the balance of the impeller being affected.

3.2 When handling the equipment, care should be taken with corners and edges and that the weight distribution within the unit is considered. Lifting gear such as slings or ropes must be arranged so as not to bear on the casing.

3.3 Equipment stored on site prior to installation should be protected from the weather and steps taken to prevent ingress of contaminants.

4.0 OPERATIONAL LIMITS

4.1 It is important that the specified operational limits for the equipment are adhered to e.g. operational air temperature, air borne contaminants and unit orientation.

4.2 Where installation accessories are supplied with the specified equipment eg. wall mounting brackets. They are to be used to support the equipment only. Other system components must have separate provision for support.

4.3 Flanges and connection spigots are provided for the purpose of joining to ductwork systems. They must not be used to support the ductwork.

5.0 INSTALLATION REQUIREMENTS

In addition to the particular requirements given for the individual product, the following general requirements should be noted.

5.1 Where access to any part of equipment which moves, or can become electrically live are not prevented by the equipment panels or by fixed installation detail (eg ducting), then guarding to the appropriate standard must be fitted.

5.2 The electrical installation of the equipment must comply with the requirements of the relevant local electrical safety regulations.

5.3 For EMC all control and sensor cables should not be placed within 50mm or on the same metal cable tray as 230V switched live, lighting or power cables and any cables not intended for use with this product.

6.0 COMMISSIONING REQUIREMENTS

6.1 General pre-commissioning checks relevant to safe operation consist of the following:

6.1.1 Ensure that no foreign bodies are present within the fan or casing.

6.1.2 Check electrical safety. e.g. Insulation and earthing.

6.1.3 Check guarding of system.

6.1.4 Check operation of Isolators/Controls.

6.1.5 Check fastenings for security.

6.2 Other commissioning requirements are given in the relevant product documentation.

7.0 OPERATIONAL REQUIREMENTS

7.1 Equipment access panels must be in place at all times during operation of the unit, and must be secured with the original fastenings.

7.2 If failure of the equipment occurs or is suspected then it should be taken out of service until a competent person can effect repair or examination. (Note that certain ranges of equipment are designed to detect and compensate for fan failure).

8.0 MAINTENANCE REQUIREMENTS

8.1 Specific maintenance requirements are given in the relevant product documentation.

8.2 It is important that the correct tools are used for the various tasks required.

8.3 If the access panels are to be removed for any reason the electrical supply to the unit must be isolated.

8.4 A minimum period of two minutes should be allowed after electrical disconnection before access panels are removed. This will allow the impeller to come to rest. NB: Care should still be taken however since airflow generated at some other point in the system can cause the impeller to "windmill" even when power is not present.

8.5 Care should be taken when removing and storing access panels in windy conditions.