

mrXbox70

Mechanical Ventilation with Heat Recovery

Installation and Maintenance

1.0 Introduction

mrXbox70 is designed to provide mechanical supply and extract ventilation with heat recovery.

Figure 1.

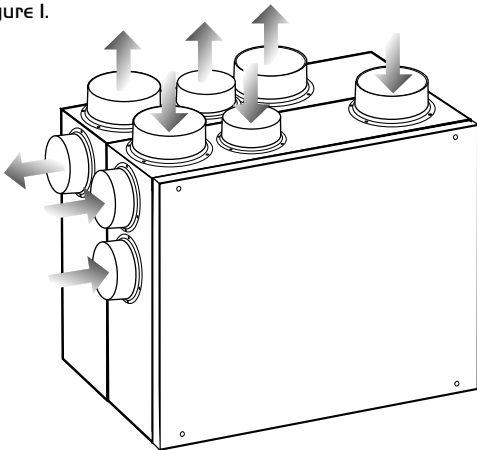

The unit is fitted with two independent fans. Each fan has full speed control for background and boost ventilation rates as well as a run-on timer facility. To recover heat from the extract air an aluminium heat exchanger block is utilised. This heat exchanger can recover over 70% of the normally wasted heat.

Figure 2. Fixing the unit to the wall.

Two mounting bracket tongues engage with slots in top edge of unit casing.

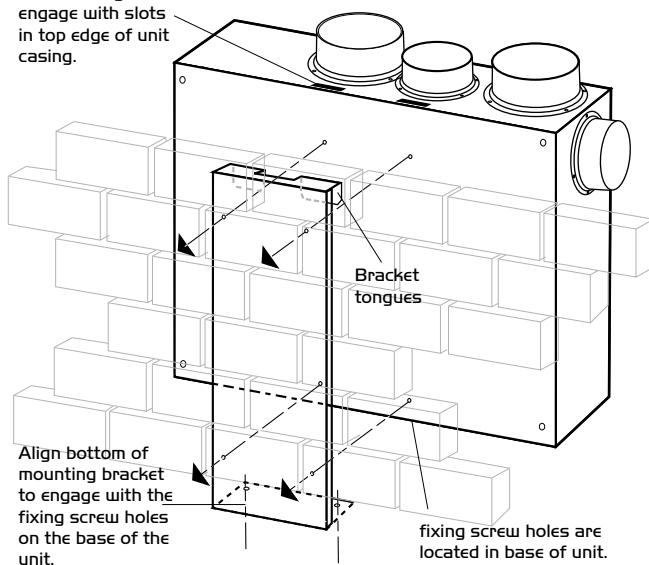

2.0 Installation

Installation must be carried out by competent personnel in accordance with the appropriate authority and conforming to all statutory governing regulations.

Please note a clear working space is required around the installed unit to allow the cover to be removed and provide sufficient access for maintenance such as filter change.

Mounting bracket

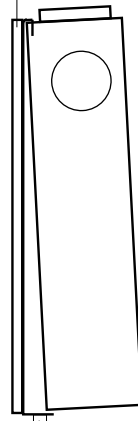

Figure 3.

The fan must be installed indoors, away from any direct sources of heat, water spray or moisture generation. Temperature range -5 to 40°C .

The unit is designed for wall mounting only. The integral mounting bracket should be offered up to the wall and the fixing points marked through and the bracket installed with 4 screws (by others). (figure 2).

To aid installation the case is split into two halves. To split the case firstly remove the front cover. Remove the four lower screws and loosen the top two.

The top section can now be removed. The rear section can be offered up to the bracket and secured with the two screws (see figure 3).

Note: Carry out all required electrical connections before fitting the front section. Refer to section 4.0.

Figure 4.

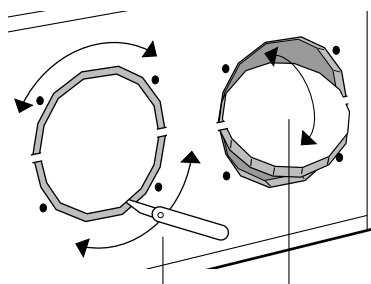

Cut through the acoustic foam round the circumference of the damper.

Damper can be swivelled on the 2 body casing hinges.

Figure 5.

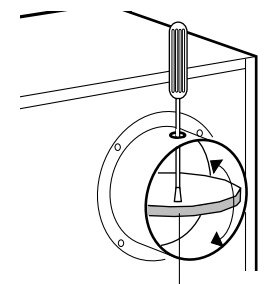

When spigot is in position, damper can be adjusted using a screwdriver.

Various damper/inlet spigot positions can be utilised as required to suit the system ductwork and extract grilles. All inlet dampers are 'closed' as knockouts when delivered but can be opened using a sharp knife. (See figure 4). After the spigot has been fixed adjust the damper with a screwdriver. (See figure 5). Fit front section and secure with screws previously removed/loosened.

See figures 6 and 8 for spigot location and sizes.

Figure 6. Main unit components.

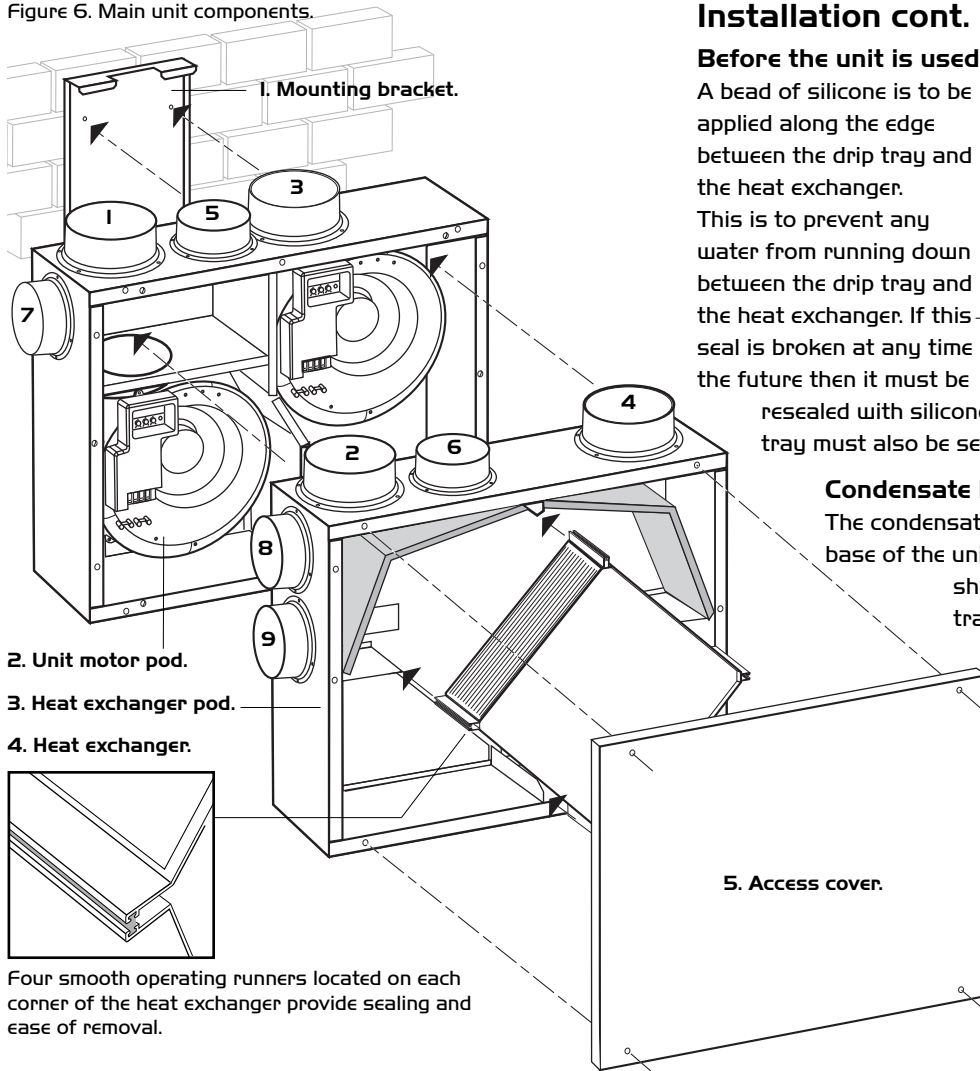

Installation cont.

Before the unit is used

A bead of silicone is to be applied along the edge between the drip tray and the heat exchanger. This is to prevent any water from running down between the drip tray and the heat exchanger. If this seal is broken at any time in the future then it must be resealed with silicone. The fixing screw in the drip tray must also be sealed with silicone.

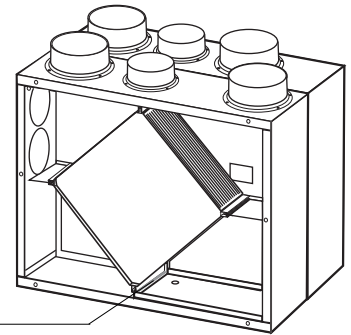

Figure 7.

Condensate Drain

The condensate drain tube protrudes from the base of the unit (see figure 8). The condensate should be disposed of via a water trap connection to the outside of the property or connected to the house sewage system.

Spigot location and airflow:

- Supply air to house - spigots 1, 5, and 7.
- Extract air to outside - spigot 3.
- Fresh air from outside - spigot 4.
- Extract from kitchen/ bathroom etc - spigots 2, 6, 8 and 9.

IMPORTANT

Any air intake terminal **MUST** be installed in accordance with the appropriate regulation. As a guide, the B55440 series of British Standards deals with this issue and currently states that an air intake must be at a minimum distance of 300mm from a gas boiler balanced flue. Installers are advised to be aware of the requirements of this standard when installing 'through the wall' supply air ducting. Similarly, supply and extract air grilles should be at least 300mm apart.

3.0 Dimensions

Figure 8. Dimensions in mm.

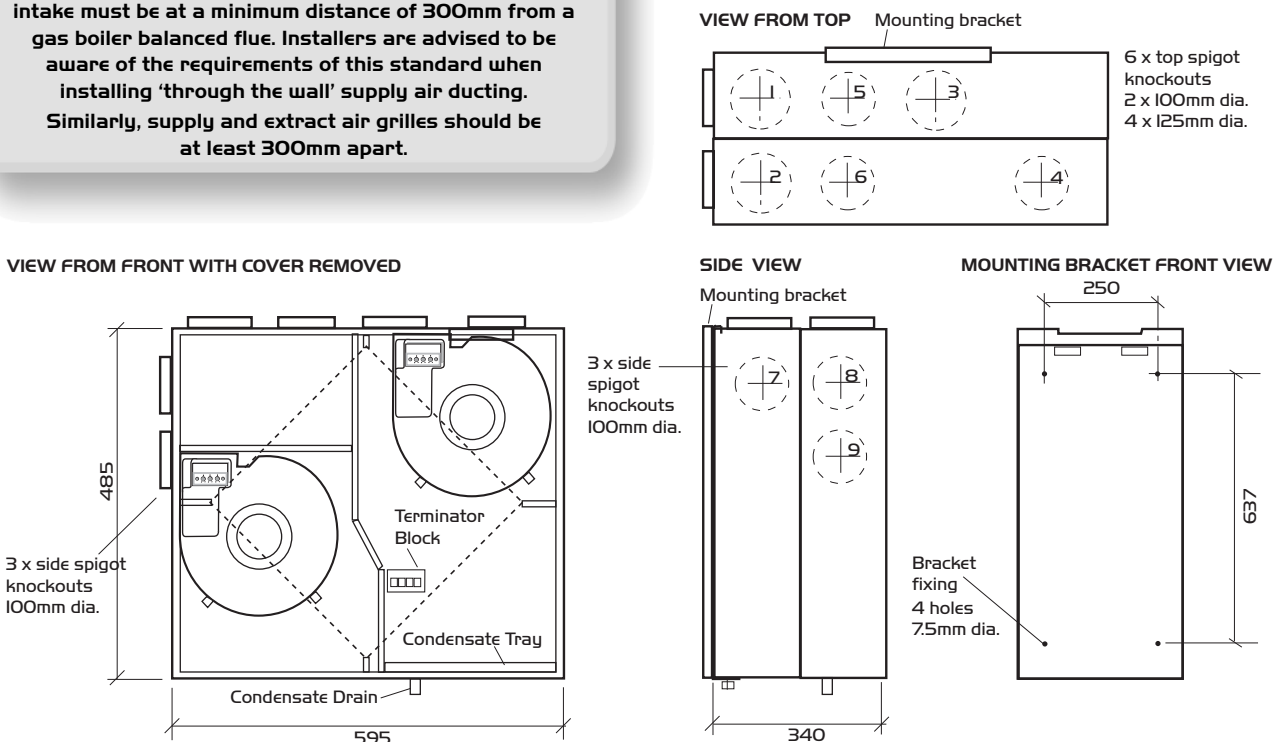

4.0 Electrical Wiring

IMPORTANT

Isolation - Before commencing work make sure that the unit, switched live and Nuair control are electrically isolated from the mains supply. Note this product must be earthed. Carry out all required electrical connections before fitting the front section.

Figure 9. Terminal Block Connections.

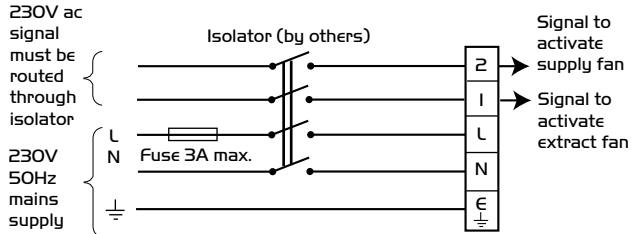

The unit is designed to be wired directly to the mains supply through a fused spur isolator (by others). With the rear section only fixed in position bring the mains wiring through the supplied cable gland (this gland can be moved to the side position if required).

Additional grommets holes are provided to allow additional wiring to each blower.

The two fans are pre-wired into an internal wiring block for ease of connection. (see figure 9 for connection details). All incoming mains connections must be routed through a suitable local isolator for maintenance purposes.

IMPORTANT

For good EMC engineering practice, any sensor cables or switched live cables should not be placed within 50mm of other cables or on the same metal cable tray as other cables.

4.1 Additional Control Wiring Option

Other control wirings are available on each fan. Open the cover of the unit to gain access to these connections on each fan (see figure 10).

Figure 10.

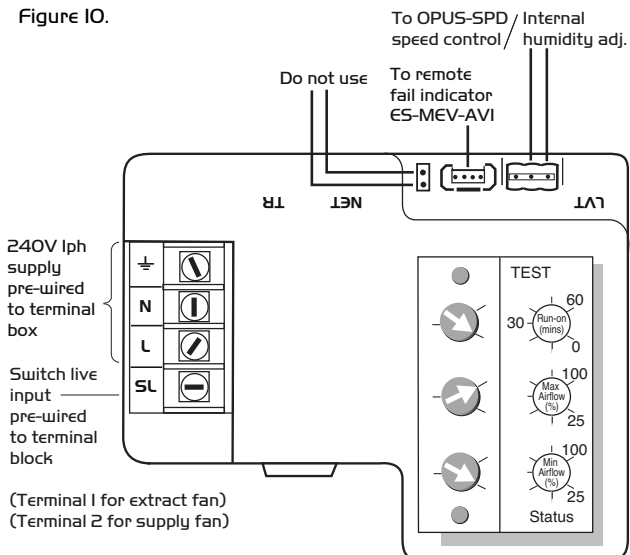

IMPORTANT

Unit must not be switched off, product is designed to run continuously.

5.0 Setting to Work

Each fan is factory set to operate at trickle airflow when power is applied and switch over to the boost flow rate when a switched live signal is present. The pot marked 'MIN Airflow' adjusts the trickle flow rate and the boost flow rate by the pot marked 'MAX Airflow'. These flow rates for the supply and extract fan are adjusted separately. When the switched live signal is removed, the fan will continue to run at boost flow rate for a preset period as dictated by the pot marked 'RUN-on'.

6.0 Run-on Timer

The Run-on timer adjustment is from 0 - 60 mins. Run-on is only available from the switched live (SL) signal.

7.0 Maintenance

It is inevitable that even with filtered extract grilles as recommended in BRE digest 398 some dust, fluff etc. will pass through the filter, and which, if allowed, will build up internally on motors and impellers, shortening the life of the unit and, in severe cases, leading to overheating of the motors. Consequently, it is strongly recommended that all units are inspected and cleaned every 18 months.

8.0 Cleaning

Remove covers and carefully clean out interiors as necessary. To clean the filters, remove from the unit and vacuum clean or wash in tepid water to which a little detergent has been added. Shake out excess water and allow to dry naturally. Replace when dry. The heat exchanger core can be safely cleaned in a domestic dish washer. Check for damage and security of components. Refit covers.

9.0 Replacement of Parts

Should any component need replacing Nuair keep extensive stocks for quick delivery. Ensure that the unit is electrically isolated, before carrying out any work. When ordering spare parts, please quote the serial number of the unit and the ARC number of the purchase if possible. (This information will be available on the fan label).

10.0 Warranty

The 5 year warranty starts from the day of delivery and includes parts and labour for the first year and parts only for the remaining 4 years. This warranty is conditional on planned maintenance being undertaken.

11.0 Service Enquiries

Nuair can assist you in all aspects of service. Our service department will be happy to provide any assistance required, initially by telephone and if necessary arrange for an engineer to call.



**Customer Services Department
on 08705 002 555**

DECLARATION OF INCORPORATION AND INFORMATION FOR SAFE INSTALLATION, OPERATION AND MAINTENANCE

We declare that the machinery named below is intended to be assembled with other components to constitute a system of machinery. The machinery shall not be put into service until the system has been declared to be in conformity with the provisions of the EC Machinery Directive.

Designation of machinery: MRXBOX70
Machinery Types: Mechanical Ventilation with Heat Recovery
Relevant EC Council Directives: 98/37/EC as amended by 98/79/EC (Machinery Directive)
Applied Harmonised Standards: BS EN ISO 12100-1, BS EN ISO 12100-2, EN294, EN60204-1, BS EN ISO 9001
Applied National Standards: BS848 Parts One, Two and Five

Signature of manufacture representatives:

Name:	Position:	Date:
1) C. Biggs 	Technical Director	20. 07. 07
2) W. Glover 	Manufacturing Director	20. 07. 07

INFORMATION FOR SAFE INSTALLATION, OPERATION AND MAINTENANCE OF NUAIRE VENTILATION EQUIPMENT

To comply with EC Council Directives 98/37/EC Machinery Directive and 2004/108/EC (EMC).

To be read in conjunction with the relevant Product Documentation (see 2.1)

1.0 GENERAL

1.1 The equipment referred to in this Declaration of Incorporation is supplied by Nuairé to be assembled into a ventilation system which may or may not include additional components.

The entire system must be considered for safety purposes and it is the responsibility of the installer to ensure that all of the equipment is installed in compliance with the manufacturers recommendations and with due regard to current legislation and codes of practice.

2.0 INFORMATION SUPPLIED WITH THE EQUIPMENT

2.1 Each item of equipment is supplied with a set of documentation which provides the information required for the safe installation and maintenance of the equipment. This may be in the form of a Data sheet and/or Installation and Maintenance instruction.

2.2 Each unit has a rating plate attached to its outer casing. The rating plate provides essential data relating to the equipment such as serial number, unit code and electrical data. Any further data that may be required will be found in the documentation. If any item is unclear or more information is required, contact Nuairé.

2.3 Where warning labels or notices are attached to the unit the instructions given must be adhered to.

3.0 TRANSPORTATION, HANDLING AND STORAGE

3.1 Care must be taken at all times to prevent damage to the equipment. Note that shock to the unit may result in the balance of the impeller being affected.

3.2 When handling the equipment, care should be taken with corners and edges and that the weight distribution within the unit is considered. Lifting gear such as slings or ropes must be arranged so as not to bear on the casing.

3.3 Equipment stored on site prior to installation should be protected from the weather and steps taken to prevent ingress of contaminants.

4.0 OPERATIONAL LIMITS

4.1 It is important that the specified operational limits for the equipment are adhered to e.g. operational air temperature, air borne contaminants and unit orientation.

4.2 Where installation accessories are supplied with the specified equipment eg. wall mounting brackets. They are to be used to support the equipment only. Other system components must have separate provision for support.

4.3 Flanges and connection spigots are provided for the purpose of joining to duct work systems. They must not be used to support the ductwork.

4.4 In the event of RF interference the fan may increase in speed or make high pitched noises. This is normal and will have no adverse effect on the fan. The speed and noise will return to normal once the interference has subsided.

5.0 INSTALLATION REQUIREMENTS

In addition to the particular requirements given for the individual product, the following general requirements should be noted.

5.1 Where access to any part of equipment which moves, or can become electrically live are not prevented by the equipment panels or by fixed installation detail (eg ducting), then guarding to the appropriate standard must be fitted.

5.2 The electrical installation of the equipment must comply with the requirements of the relevant local electrical safety regulations.

5.3 For EMC all control and sensor cables should not be placed within 50mm or on the same metal cable tray as 230V switched live, lighting or power cables and any cables not intended for use with this product.

6.0 COMMISSIONING REQUIREMENTS

6.1 General pre-commissioning checks relevant to safe operation consist of the following:

Ensure that no foreign bodies are present within the fan or casing.

Check electrical safety. e.g. Insulation and earthing.

Check guarding of system.

Check operation of Isolators/Controls.

Check fastenings for security.

6.2 Other commissioning requirements are given in the relevant product documentation.

7.0 OPERATIONAL REQUIREMENTS

7.1 Equipment access panels must be in place at all times during operation of the unit, and must be secured with the original fastenings.

7.2 If failure of the equipment occurs or is suspected then it should be taken out of service until a competent person can effect repair or examination. (Note that certain ranges of equipment are designed to detect and compensate for fan failure).

8.0 MAINTENANCE REQUIREMENTS

8.1 Specific maintenance requirements are given in the relevant product documentation.

8.2 It is important that the correct tools are used for the various tasks required.

8.3 If the access panels are to be removed for any reason the electrical supply to the unit must be isolated.

8.4 A minimum period of two minutes should be allowed after electrical disconnection before access panels are removed. This will allow the impeller to come to rest.

NB: Care should still be taken however since airflow generated at some other point in the system can cause the impeller to "windmill" even when power is not present.

8.5 Care should be taken when removing and storing access panels in windy conditions.

Technical or commercial considerations may, from time to time, make it necessary to alter the design, performance and dimensions of equipment and the right is reserved to make such changes without prior notice.