

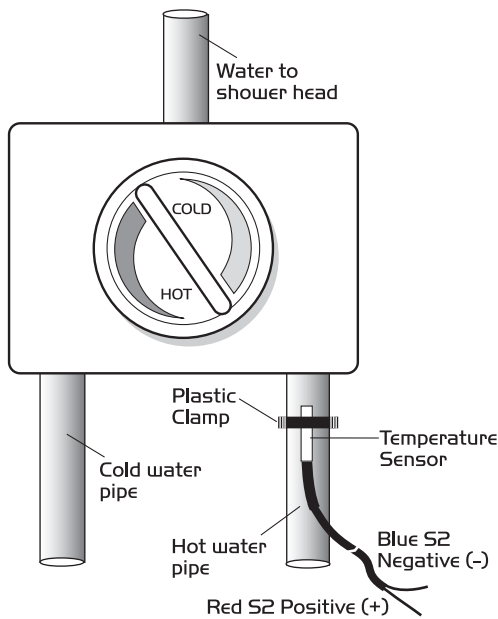



- 23. Turn down the Load Pot to the mid position and Time Pot to minimum.
- 24. Turn on the shower wait 30 seconds after the hot water is being delivered, if the middle LED does not light up, then turn the load pot very slightly in an anticlockwise direction, do not turn the Pot below the 50% position as this will allow the fan to run when not required. If a lower setting is needed first check that the temperature of the hot water is above 60°C as it should be to kill off legionella, if it is at this temperature then the integrity of the conduction of heat from the pipe to the sensor should be carefully checked.
- 25. Now set the time pot by turning it clockwise. It has a range of 1 to 25 minutes for optimum performance and energy conservation, a 20 minute overrun time is probably the best starting point. **N.B. the overrun time should be set to ensure the fan clears all residual steam after showering has finished.**
- 26. Turn off the fused spur and fit the front cover plate to complete the installation.

Figure 4. Typical temperature sensor installation.



### 2.3 Operation both Current and Temperature

Set the on/off switch on the fan to the on position and fix. Set the speed setting to the level which will provide sufficient ventilation to remove all steam and condensation within the run on period.

**Additional Sensor** - An additional sensor may be installed with either version these should be installed in the same manner as described above except the additional sensors should be wired into S2 as shown in figure 3. **N.B. During field trials it was noted that RF emissions from certain fans can cause interference which results in intermittent problems with the on board microprocessor.** Nuair cannot be held responsible for such occurrences however, if this problem is encountered with your installation we will use best endeavours to resolve the problem. Please contact us to discuss the solutions to such problems.

Figure 5. Typical wiring to boost fan or MEV.

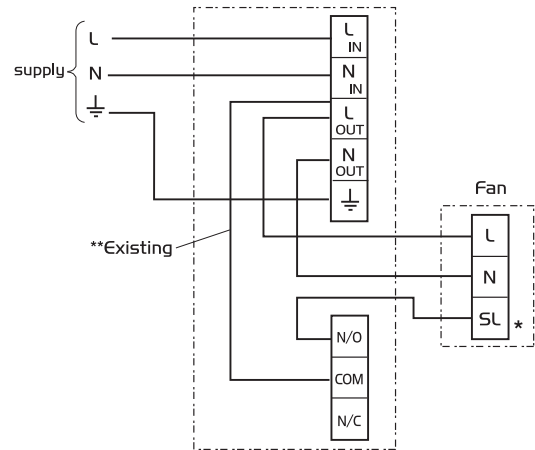

**\*Refer to fan installation and maintenance document for specific terminal identification. Run-on-timer in fan to be set to minimum.**

Figure 6. Wiring for on/off installation with facility for adjustable run-on-timer.

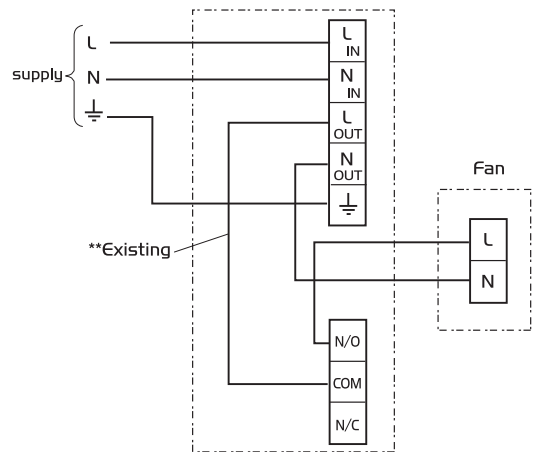

**IMPORTANT**  
**\*\*If used for volt-free switching e.g. for Nuair HPKF, this link has to be removed and the COM and N/O connections used.**

Figure 7. Set points on the temperature potentiometer.

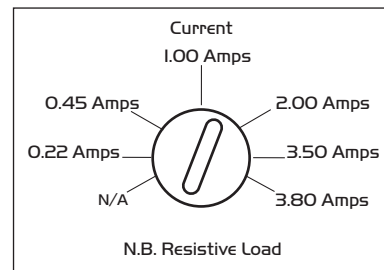
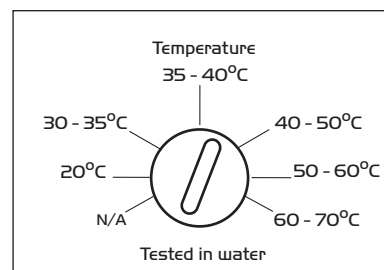

Figure 8. Set points on the current potentiometer.



### 2.4 Installing a manual fan push switch (momentary) e.g. MK - Reference: K4878P-WHI

27. Turn off the fused spur to the control unit and remove the front cover.
28. Wire the cable into the terminals as indicated in the wiring diagram figure 3 (i.e. **VERRIDE**).
29. Run the cable to suitable location for the override switch and fix securely.
30. Test the operation of the switch. Push and hold until the fan starts running, this will give an override time of approximately 25 minutes. Push and hold the switch until the fan turns off, this will disable the override during the 25 minute period.
31. Turn off the fused spur and fit the front cover to complete the installation.

### 3.0 Special Notes regarding Temperature Sensing

**IMPORTANT**

Where plastic pipework is used a section of copper pipe will need to be introduced for sensing purposes.

1. There will be an inevitable delay between hot water being delivered at point of use and the controller sensing the temperature, this is due to the time taken by the conduction of heat from the water through to the outside of the pipe and then to the clamp on sensor. This time delay will vary with ambient conditions, hot water temperature and pipe wall thickness. it is most important therefore that great care is taken when fixing the sensor to maximise the heat conduction process. Please pay particular attention to cleaning the pipe, applying the thermal grease and clamping the sensor.
2. Similarly there will be a delay in the unit turning off the fan as it will take time for the dead leg to loose heat, again this will vary with ambient conditions, hot water temperature and pipe wall thickness. The time of this natural cooling process should be taken account of when setting the run on timer. As a guide, at an ambient temperature 21°C and a hot water temperature of 50°C. the cooling down process will be 5 – 10 minutes and this should be taken into account when setting the overrun timer.

### 4.0 Trouble shooting

Problem	Action to determine the fault
1. The LED does not blink.	Check that there is 240 volts between Live in and Neutral
2. The middle LED does not illuminate	Fit wire across overrun terminals this will prove sensor i.e. if the LED illuminates check sensor wiring.

### 5.0 Maintenance

The unit does not require any maintenance. However, for optimum performance, it is advisable to remove any accumulated dust with a low power vacuum cleaner.

NOTE: Installation and Maintenance of the equipment must be as directed in the instructions provided with the unit.

### 6.0 Warranty

The 1 year warranty starts from the day of delivery and includes parts and labour.

This warranty is void if the equipment is modified without authorisation, is incorrectly applied, misused, disassembled, or not installed, commissioned and maintained in accordance with the details contained in this manual and general good practice.

The product warranty applies to the UK mainland and in accordance with Clause 14 of our Conditions of Sale. Customers purchasing from outside of the UK should contact Nuaire International Sales office for further details.

### 7.0 After Sales Enquiries

For technical assistance or further product information, including spare parts and replacement components, please contact the After Sales Department.

**Telephone 02920 858 400**

Technical or commercial considerations may, from time to time, make it necessary to alter the design, performance and dimensions of equipment and the right is reserved to make such changes without prior notice.