



# EZPLATE

## Plate Axial Fans 50/60Hz Installation and Maintenance

### Introduction

EZPLATE axial fans are manufactured in a range of ten sizes. 315mm to 1000mm dia. and are available in 4, 6 and 8 pole options. The motors are fitted as standard, with a thermal protection device (stat type) with the motor and stat leads brought out and connected in a terminal box.

### Code Description

EZPLATE560-4 3 H  
| 2 | 3 | 4 | 5

1. EZPlate Range
2. Fan impeller diameter (mm)
3. 4 = 4 Pole motor  
6 = 6 pole motor  
8 = 8 Pole motor
4. 1 = Single phase unit  
3 = 3 phase unit
5. No suffix = 50Hz  
H = 60Hz

### 1.0 Handling

Always handle the units carefully to avoid damage and distortion, do not lift by the impeller and take care when using lifting slings.

### 2.0 Installation

Installation must be carried out by competent personnel in accordance with the appropriate authority and conforming to all statutory and governing regulations e.g. I.E.E., CIBSE, etc.

The fan must be fitted indoors on a secure flat surface away from sources of heat, water spray or steam generation. From the fan rating plate, observe the weight of the unit and select a mounting position and structure that can support the fan.

Prepare a hole in the surface to accept the unit, ensuring the structure is not weakened by the hole and with the appropriate fixings secure the unit taking care not to distort the fan plate. It may be advisable to line the aperture, particularly if a cavity wall. Use the appropriately sized propriety wall fixing kit.

### Wall Fixing Kit

Figure 1.

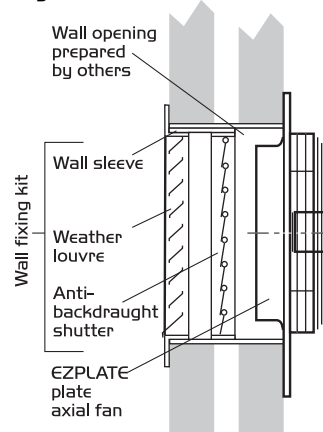

Suitable for horizontal airflow only, the wall kit is supplied ready for use and consists of three main components.

1. A metal external weather louvre c/w with bird screen.
2. A gravity operated backdraught shutter manufactured in polypropylene.
3. A wall sleeve housing the assembly.

To fit, cut the appropriately sized hole, offer the wall kit, fix and seal. (See figure 2).

### 3.0 Dimensions (mm) & Weights

Figure 2.

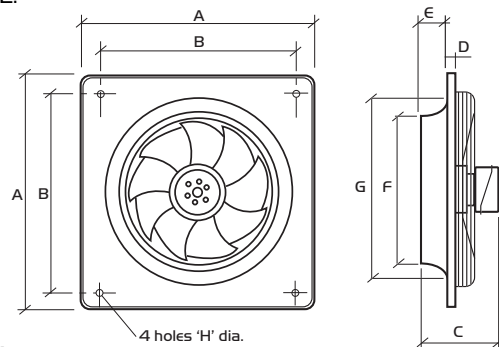

#### 4 Pole

Fan Code	A	B	C	D	E	F	G	H dia	Weight kg
EZPLATE315	430	380	135	11	70	324	330	9	5.0
EZPLATE350	485	435	148	12	75	368	375	9	7.0
EZPLATE400	540	490	165	12	88	412	420	9	8.0
EZPLATE450	575	535	161	14	96	463	480	11	11.0
EZPLATE500	655	615	198	16	104	517	535	11	18.0
EZPLATE560	725	675	245	16	119	568	600	11	21.0
EZPLATE630	805	750	245	20	130	643	670	11	31.0

Note: Inlet guard included.

#### 6 Pole

Fan Code	A	B	C	D	E	F	G	H dia	Weight kg
EZPLATE450	575	535	161	14	96	463	480	11	11.0
EZPLATE500	655	615	198	16	104	517	535	11	18.0
EZPLATE560	725	675	218	16	120	568	590	11	21.0
EZPLATE630	805	750	218	20	130	643	670	11	25.0
EZPLATE710	850	810	245	20	150	721	765	14.5	35.0
EZPLATE800	970	910	245	20	190	807	870	14.5	50.0

Note: Inlet guard not included for 710mm and 800mm fan units.

#### 8 Pole

Fan Code	A	B	C	D	E	F	G	H dia	Weight kg
EZPLATE800	970	910	245	20	190	807	870	14.5	50.0
EZPLATE1000	1170	1135	323	20	285	1016	1067	14.5	74.6

Note: Inlet guard not included for 800mm and 1000mm fan units.

### 3.1 Dimensions Gravity Backdraught Shutter

The units offer negligible resistance and are manufactured from impact resistant polypropylene, stabilised against ultra-violet light, finished in grey.

Fixing to the wall is by four screws. When closed the louvres are contained inside the raised edge of the casing, reducing flapping to a minimum. A circular hole is provided in the rear of the frame to match the fan outlet.

Figure 3.

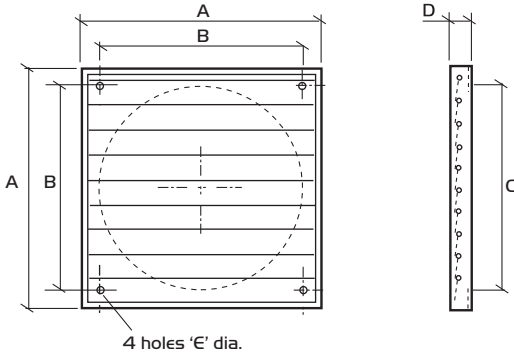

Shutter Dimensions (mm)

Unit Code	A	B	C	D	€ dia
P315BS	347	276	310	26	9
P350BS	397	310	360	26	9
P400BS	459	364	420	26	9
P450BS	501	395	460	26	11
P500BS	549	445	510	31	11
P560BS	604	522	565	31	11
P630BS	697	628	657	31	11
P710BS	760	720	692	40	N/A
P800BS	840	800	772	40	N/A
P1000BS	1040	1000	972	40	N/A

### 3.2 Dimensions Wall Fixing Kit

Supplied assembled, the louvre is high grade aluminium alloy, natural finish. The shutter is manufactured from polypropylene, stabilised against ultra-violet light, finished in grey.

The wall sleeve combines the components ready for installation into a wall opening (prepared by others).

The Kit is suitable for vertical mounting only.

Figure 4.

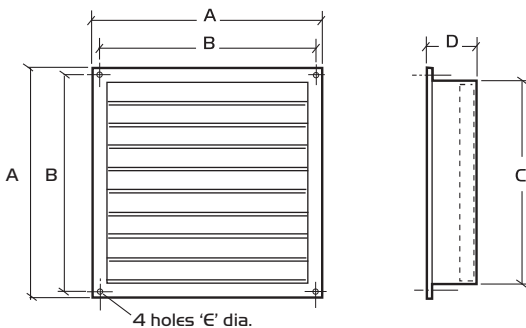

Wall Kit Dimensions (mm)

Unit code	A	B	C	D	€ dia.
P315WK	415	385	362	203	6
P350WK	463	432	407	203	6
P400WK	526	495	470	203	6
P450WK	568	537	513	203	6
P500WK	616	583	560	203	6
P560WK	668	637	613	203	6
P630WK	712	682	661	203	6

### 4.0 Electric wiring

#### Single Phase Fans Single Speed units

Note: Failure to connect Thermal Protection TB or TK as shown will invalidate warranty

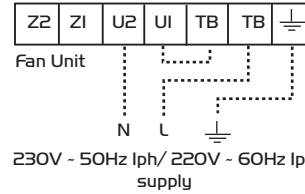

#### Three Phase Fans Single Speed units

(Interchange any two Fan supply phases to reverse rotation)

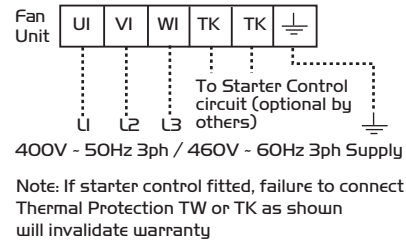

#### Units with ELECTRONIC Speed Control

Note: Failure to connect Thermal Protection TB or TK as shown will invalidate warranty

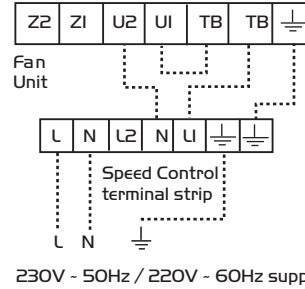

#### Unit with Speed Control INVERTER TYPE 3SC INV

NOTE: Refer to instructions supplied with Inverter for specific wiring details. Inverter instructions must be strictly observed

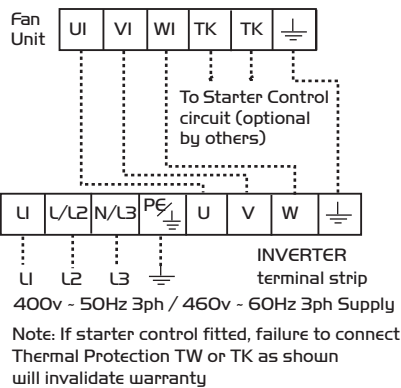

#### Units with AUTO-TRANSFORMER Speed Control

Note: Failure to connect Thermal Protection TB or TK as shown will invalidate warranty

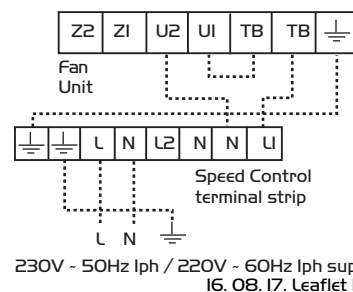

## 5.0 Maintenance

### IMPORTANT

**Isolation - Before commencing work make sure that the unit and Nuair control are electrically isolated from the mains supply.**

Fans and systems should be maintained in accordance with the HVCA Standard Maintenance Recommendations for Mechanical Services in Buildings' Volume II Ventilation and Air conditioning.

### For Guidance only

Due to the different periods of operation from the time of installation and conditions of use, no rigid inspection and maintenance periods can be recommended. We suggest, therefore that the inspection and if necessary cleaning/bearing check should be carried out at regular intervals of a maximum of six months.

For a routine inspection, check the tightness of all nuts, keys, grub screws and endbolts etc. Remove any build up of dirt or dust with a brush. Do not use any solvents or immerse the unit in water.

### 5.1 Maintenance check list

Item	Tick
Check that finger guard/safety grilles are secure and free of obstruction.	
Inspect all bolts, fixings and electrical terminals for security.	
Check motor for undue wear, signs of overheating and apply winding insulation and continuity tests.	
Remove all dust and dirt from impellers, be especially careful not to disturb balance weights.	
Generally clean.	
Check resilient mounts and replace any that show signs of wear or deterioration.	

### 5.2 Lubrication

Motors are fitted with sealed for life bearings and do not require any lubrication.

## 6.0 Replacement of Parts

Should any component need replacing Nuair keep extensive stocks for quick delivery. Ensure that the unit is electrically isolated, before carrying out any work.

When ordering spare parts, please quote the serial number of the unit and the ARC number of the purchase if possible.

**(This information will be available on the fan label).**

## 7.0 Warranty

EZPLATE has a 3 year warranty. The warranty starts from the day of delivery and includes parts and labour for the first year, the remaining years covers replacement parts only.

This warranty is void if the equipment is modified without authorisation, is incorrectly applied, misused, disassembled, or not installed, commissioned and maintained in accordance with the details contained in this manual and general good practice.

The product warranty applies to the UK mainland and in accordance with Clause 14 of our Conditions of Sale.

Customers purchasing from outside of the UK should contact Nuair International Sales office for further details.

## 8.0 After Sales Enquiries

For technical assistance or further product information, including spare parts and replacement components, please contact the After Sales Department.



**Telephone 02920 858 400**

## DECLARATION OF INCORPORATION AND INFORMATION FOR SAFE INSTALLATION, OPERATION AND MAINTENANCE

We declare that the machinery named below is intended to be assembled with other components to constitute a system of machinery. All parts except for moving parts requiring the correct installation of safety guards comply with the essential requirements of the Machinery Directive. The machinery shall not be put into service until the system has been declared to be in conformity with the provisions of the EC Machinery Directive.

**Designation of machinery:** EZPLATE  
**Machinery Types:** Plate Axial Fan  
**Relevant EC Council Directives:** 2006/42/EC (Machinery Directive)  
**Applied Harmonised Standards:** BS EN ISO 12100-1, BS EN ISO 12100-2, EN60204-1, BS EN ISO 9001, BS EN ISO 13857  
**Applied National Standards:** BS848 Parts 1, 2.2 and 5  
 Note: All standards used were current and valid at the date of signature.

### Signature of manufacture representatives:

Name:	Position:	Date:
1) C. Biggs 	Technical Director	1.09.11
2) A. Jones 	Manufacturing Director	1.09.11

## INFORMATION FOR SAFE INSTALLATION, OPERATION AND MAINTENANCE OF NUAIRE VENTILATION EQUIPMENT

To comply with EC Council Directives 98/37/EC Machinery Directive and 2014/30/EU (EMC).

To be read in conjunction with the relevant Product Documentation (see 2.1)

### 1.0 GENERAL

1.1 The equipment referred to in this Declaration of Incorporation is supplied by Nuairé to be assembled into a ventilation system which may or may not include additional components.

The entire system must be considered for safety purposes and it is the responsibility of the installer to ensure that all of the equipment is installed in compliance with the manufacturers recommendations and with due regard to current legislation and codes of practice.

### 2.0 INFORMATION SUPPLIED WITH THE EQUIPMENT

2.1 Each item of equipment is supplied with a set of documentation which provides the information required for the safe installation and maintenance of the equipment. This may be in the form of a Data sheet and/or Installation and Maintenance instruction.

2.2 Each unit has a rating plate attached to its outer casing. The rating plate provides essential data relating to the equipment such as serial number, unit code and electrical data. Any further data that may be required will be found in the documentation. If any item is unclear or more information is required, contact Nuairé.

2.3 Where warning labels or notices are attached to the unit the instructions given must be adhered to.

### 3.0 TRANSPORTATION, HANDLING AND STORAGE

3.1 Care must be taken at all times to prevent damage to the equipment. Note that shock to the unit may result in the balance of the impeller being affected.

3.2 When handling the equipment, care should be taken with corners and edges and that the weight distribution within the unit is considered. Lifting gear such as slings or ropes must be arranged so as not to bear on the casing.

3.3 Equipment stored on site prior to installation should be protected from the weather and steps taken to prevent ingress of contaminants.

### 4.0 OPERATIONAL LIMITS

4.1 It is important that the specified operational limits for the equipment are adhered to e.g. operational air temperature, air borne contaminants and unit orientation.

4.2 Where installation accessories are supplied with the specified equipment eg. wall mounting brackets. They are to be used to support the equipment only. Other system components must have separate provision for support.

4.3 Flanges and connection spigots are provided for the purpose of joining to duct work systems. They must not be used to support the ductwork.

### 5.0 INSTALLATION REQUIREMENTS

In addition to the particular requirements given for the individual product, the following general requirements should be noted.

5.1 Where access to any part of equipment which moves, or can become electrically live are not prevented by the equipment panels or by fixed installation detail (eg ducting), then guarding to the appropriate standard must be fitted.

5.2 The electrical installation of the equipment must comply with the requirements of the relevant local electrical safety regulations.

5.3 For EMC all control and sensor cables should not be placed within 50mm or on the same metal cable tray as 230V switched live, lighting or power cables and any cables not intended for use with this product.

### 6.0 COMMISSIONING REQUIREMENTS

6.1 General pre-commissioning checks relevant to safe operation consist of the following:

Ensure that no foreign bodies are present within the fan or casing.

Check electrical safety. e.g. Insulation and earthing.

Check guarding of system.

Check operation of Isolators/Controls.

Check fastenings for security.

6.2 Other commissioning requirements are given in the relevant product documentation.

### 7.0 OPERATIONAL REQUIREMENTS

7.1 Equipment access panels must be in place at all times during operation of the unit, and must be secured with the original fastenings.

7.2 If failure of the equipment occurs or is suspected then it should be taken out of service until a competent person can effect repair or examination. (Note that certain ranges of equipment are designed to detect and compensate for fan failure).

### 8.0 MAINTENANCE REQUIREMENTS

8.1 Specific maintenance requirements are given in the relevant product documentation.

8.2 It is important that the correct tools are used for the various tasks required.

8.3 If the access panels are to be removed for any reason the electrical supply to the unit must be isolated.

8.4 A minimum period of two minutes should be allowed after electrical disconnection before access panels are removed. This will allow the impeller to come to rest.

**NB: Care should still be taken however since airflow generated at some other point in the system can cause the impeller to "windmill" even when power is not present.**

8.5 Care should be taken when removing and storing access panels in windy conditions.

Technical or commercial considerations may, from time to time, make it necessary to alter the design, performance and dimensions of equipment and the right is reserved to make such changes without prior notice.  
 Nuairé Limited, Western Industrial, Estate Caerphilly United Kingdom CF83 1NA.