

Fig. 1. General view of unit.

### Introduction

NuAire's OPUS 30 range of surface mounted domestic extract fans are designed not only to meet the requirements of the building regulations document F1 1990, but also that of the 16th edition IEE Wiring Regulations On Site Guide.

The units are designed to ventilate bathrooms / shower rooms where the unit is to be mounted in the 'splash zone'. (See Installation section).

### Typical arrangements

surface mounting, wall or ceiling

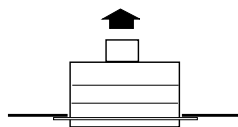

One room extraction

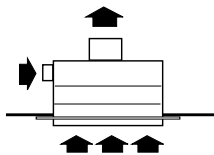

Two room extraction  
(with side subsidiary).

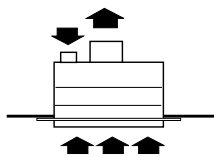

Two room extraction  
(with rear subsidiary).

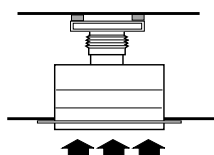

Semi recessed version

### Contents

### Page

Introduction.....	1
Arrangements and Codes.....	1
Installation.....	2
Adjusting Run on Timer .....	2
Dimensions & Ancillaries.....	3
Electrical Diagrams.....	6
Certification .....	7
Maintenance .....	8

They discharge air through 100mm. dia. pipe and have provision for adding a 50mm. dia. subsidiary inlet to extract air from a second room.

Units are available with one or two fans with a duty of 32l/s. Inlet is through filters located on the front cover of the unit and which can easily be removed for cleaning.

Units can be fitted with a selection of controls which enable them to be linked to light switches, either directly or through run-on circuits.

### Coding

- RS12** Single fan unit incorporating a run-on circuit
- 2RAS12** Twin unit incorporating both run-on and fan failure detection/change over circuits.

### Installation

Note: 'SPLASH ZONE'

The splash zone can be considered to be an area within a bathroom or shower room where a person using the bath or shower can effectively reach. An arms reach is defined as 0.6 metres from the edge of the bath or shower up to a height of 2.25 metres.

- a) An opening should be prepared to accept the fan case plus a clearance of 5 - 10mm which will be necessary to allow for the fixing brackets. Therefore an aperture of 327mm x 245mm will be required. Care must be taken during this operation as an aperture larger than 335mm x 253mm will not be covered by the front panel skirt.

## Installation (continued)

It is assumed that a solid non-reverberant mounting position has been selected, and the necessary passages for ductwork, from outlet spigot and to subsidiary inlet spigot (if a second room is to be ventilated) as well as the electrical connection prepared. It is also assumed that compatible ductwork is already installed.

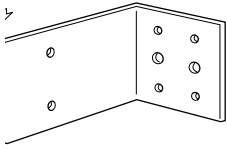

Fig.3. Selecting bracket length.

- b) Mounting brackets are supplied with all OPUS fans but, depending on the type of unit, may need to be shortened. The bracket has a series of notches, one of which is suitable for your unit. Offer up the bracket to the unit (small leg of bracket to back of unit) and note the notches which correspond with the back of the skirt. Using a hacksaw cut the bracket to length. Similarly prepare the two remaining brackets. (Fig.3).

Attach the three brackets to the large 'Y' shaped plate using the self tapping screws supplied to form a mounting frame. (See fig. 4).

Position the mounting frame in the prepared aperture so that the ends of the three cut brackets are flush with the surface of the wall. Secure the mounting frame with suitable fixings.

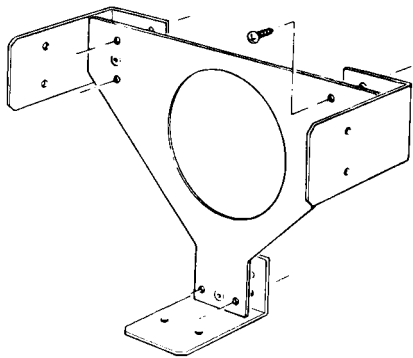

Fig. 4. Mountin

- c) Unclip and remove the fan module. Knock out a suitable cable entry hole in the rear face of the case.

If a second room is to be served remove the appropriate weakened area from the case, and, working from the inside fit the the subsidiary inlet spigot by passing it through the case and turning quarter of a turn to lock in position.

- d) Offer up the casing to the mounting frame feeding the supply cable through the entry hole. Engage the outlet spigot(s) in the ductwork and fix the casing to the frame using the three screws supplied.
- e) Connect the wiring to the internal terminal block/ socket.

- f) Fit the fan module to the case, mating it's plug fully with the internal socket. Secure in position with the two spring clips.
- g) Fit the front cover to the unit using the four screws supplied. Insert the filters into the rebates in the cover. Test / run the unit.

## Adjusting the run on timer .

Remove cover. Locate the Time Delay adjustmewnt screw on the plastic box found directly between and under the fan scroll mouldings (see fig 5). integral with the fan module. Reset against the graduated scale. Refit the cover.

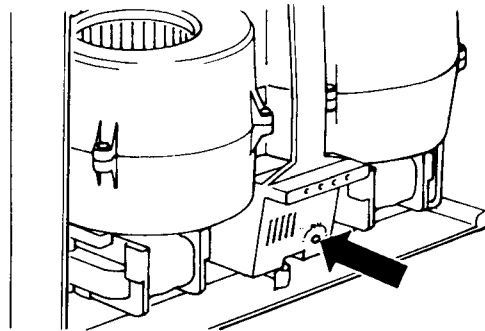

Fig. 5. Timer adjustment.

## Installing the unit into flatduct.

It is assumed that the flatduct is already fitted with a plenum section incorporating 100mm dia. spigot in the area of the proposed extract fan.

- a) Proceed as in steps (a), (b) & (c) above.
- b) Feed the 100mm flexible ducting (supplied) through the rear of the mounting frame and fit to the spigot on the flat duct plenum.
- c) Offer up the casing to the mounting frame and join the other end of the flexible ducting to the outlet spigot using tape (not supplied). Fig. 6. Feed the electrical supply cable through the entry hole and fix the case to the mounting frame using the three screws supplied.

Continue as in (e) to (h) above.

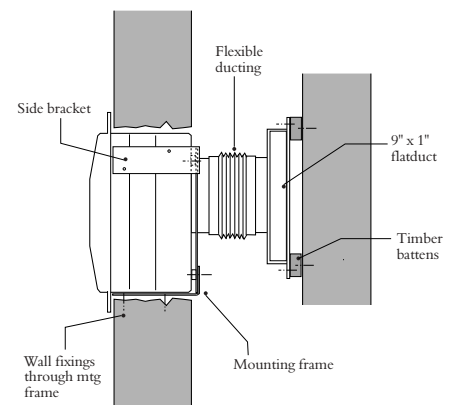
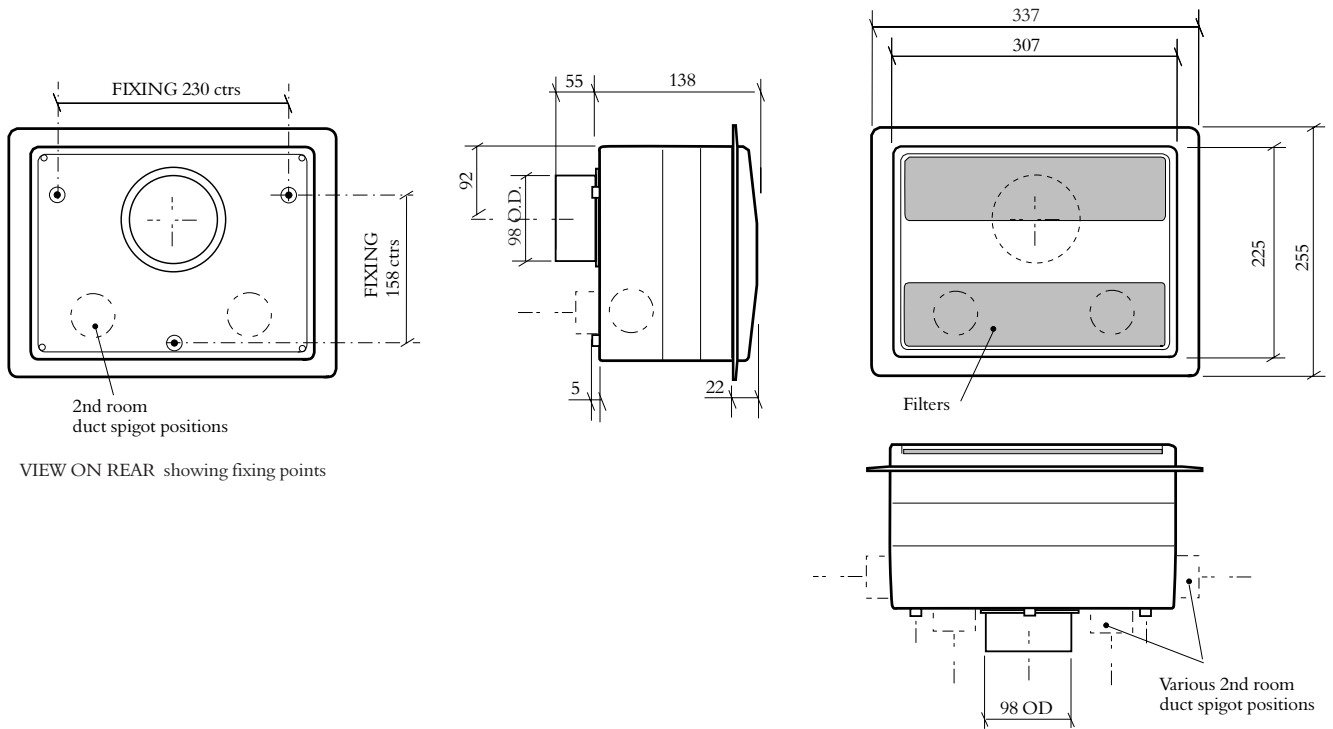

Fig. 6 Installation into flatducting

# Installation and Maintenance OPUS 12V (R range)

## Dimensions



## Optional ancillaries

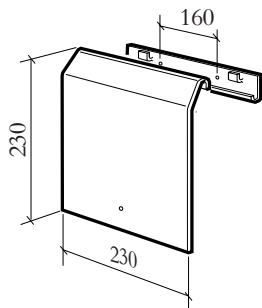

Outlet Baffle

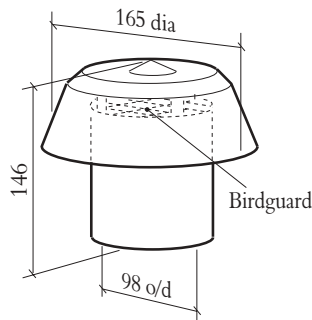

Roof Cowl

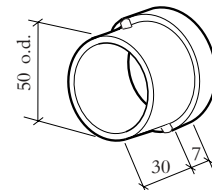

50mm Subsidiary spigot

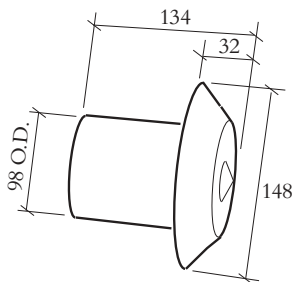

Wall Cowl

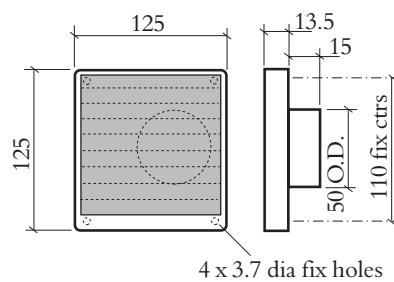

50mm Inlet grille

Fig.7  
12v Transformer  
dimension details.

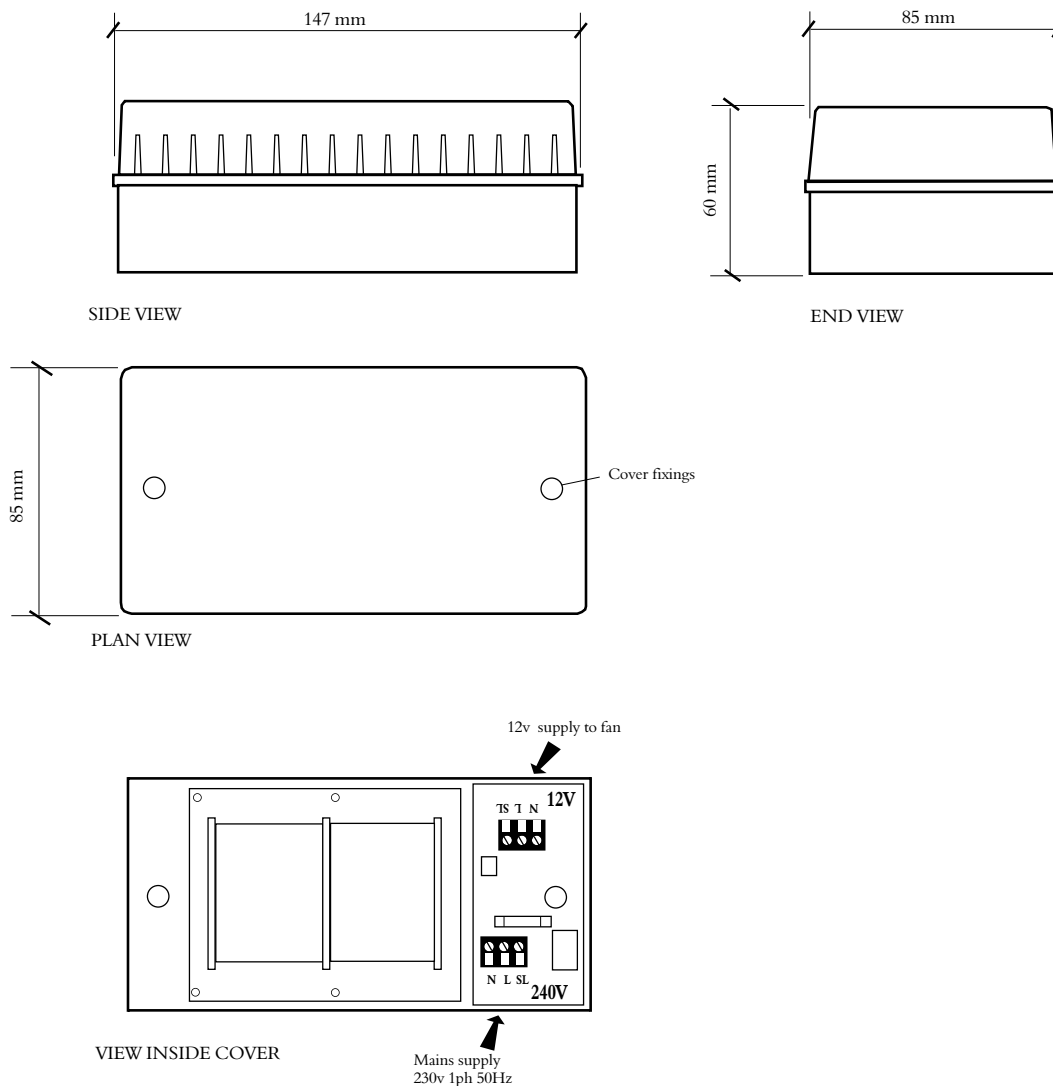

## Installation of Transformer enclosure (12 Volt units only)

The enclosure containing the transformer is intended to be mounted out of sight (e.g. in a loft, cupboard, under floorboards etc.). However, if this is not possible the transformer enclosure should be mounted as close to the ceiling, or as far from the "splash zone" as possible (see below for definition of the splash zone). As can be seen from the table of wiring sizes on page 5, it is advisable to place the enclosure as close to the fan as possible to reduce the costs of wiring and assist in installation.

### 'SPLASH ZONE'

The 'Splash Zone' can be considered to be an area within a bathroom or shower room where a person using the bath or shower can effectively reach. An arms reach is defined as 0.6 metres from the edge of the bath or shower up to a height of 2.25 metres.

## Procedure

1. Remove two screws securing the cover and remove the cover.
2. Position the base enclosure on mounting surface and route cables through knockouts. Mark the fixing points on the mounting surface and secure using suitable fixings (by others).
3. Connect wiring as shown.
4. Replace cover.  
**KEEP VENTS CLEAR OF OBSTRUCTION.**

### NOTE:

**NO EARTH IS TO BE CONNECTED BETWEEN TRANSFORMER AND FAN**

### Installation Notes:

#### WIRING SIZES

It is important to note that the size of wire used between the transformer and the fan unit can have an adverse effect on the units performance if the following table is not adhered to.

Mains supply (240v) .....0.5mm sq.

#### TRANSFORMER TO FAN

Cable run (max. 10m)	Cable size
Up to 2m	0.75mm sq.
Up to 4m	1.00mm sq.
Up to 6m	1.50mm sq.
Up to 10m	2.50mm sq.

### Power consumption

**Unit** input power (watts). .....42.0

Full load current (amps). ..... 4.2

Starting Current (amps). ..... 4.4

**Transformer** input power (watts)..... 67.0

Full load current (amps). ..... .34

Starting Current (amps). ..... .35

### Spares

#### OPUS 30 single fans

ITEM	PART No.
Front grille assembly	770874
Foam Filter set (all units).	630016
Transformer assembly	771921
<b>Internal assembly:</b>	
RS12 units	771287

#### OPUS 30 Twin fans

ITEM	PART No.
Front grille assembly	770874
Foam Filter set (all units).	630016
Transformer assembly	771285
RA12, RAS12, and all 2R type units below	771922
<b>Internal assembly:</b>	
2RAS12 units	771290

# Installation and Maintenance OPUS 12V (R range)

## Electrical Wiring Diagrams

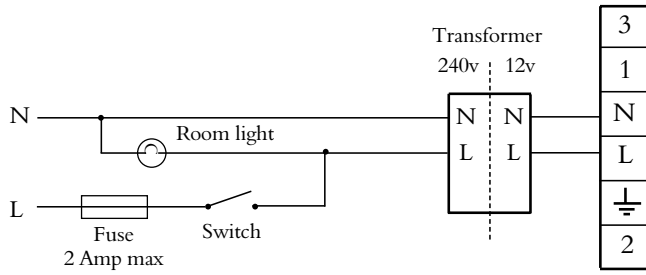

**RS12 Unit ventilating one room.**

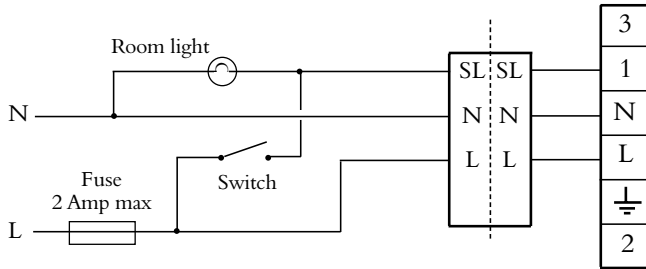

**RS12 (using run on circuit).**

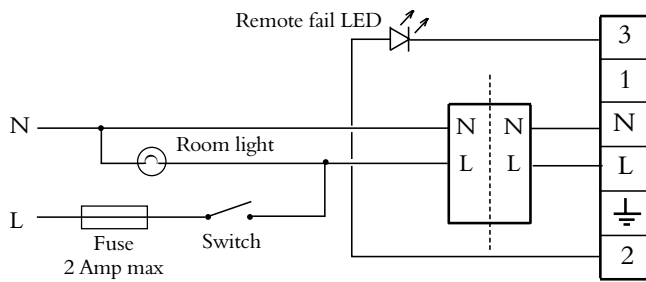

**2RAS12 (no run on timer).**

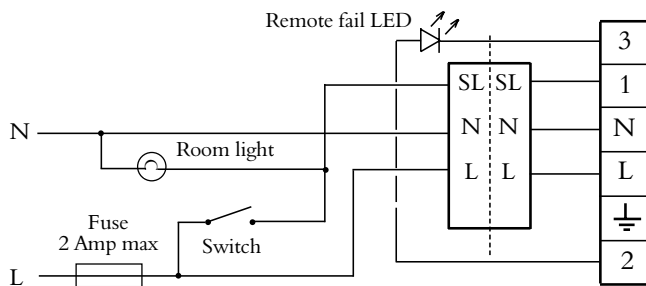

**2RAS12 Unit ventilating one room (using run on circuit).**

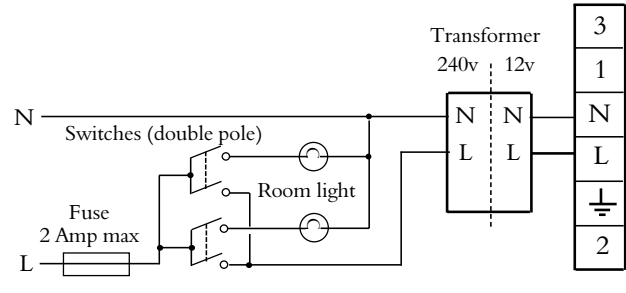

**RS12 Unit ventilating two rooms.**

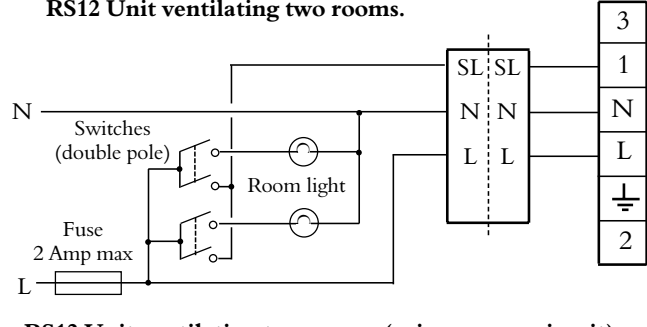

**RS12 Unit ventilating two rooms (using run on circuit).**

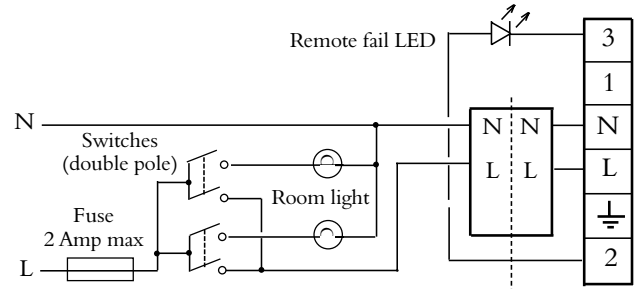

**2RAS12 Unit ventilating two rooms (no run on timer).**

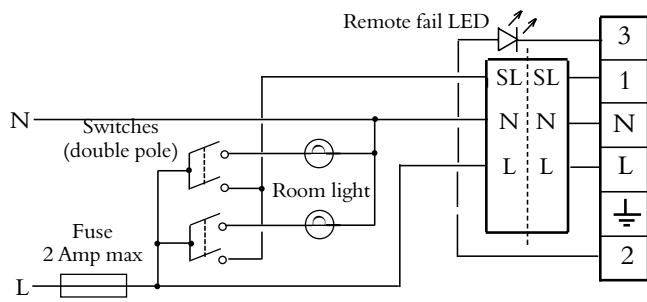

**2RAS12 Unit ventilating two rooms (using run on circuit).**

Fan terminal block

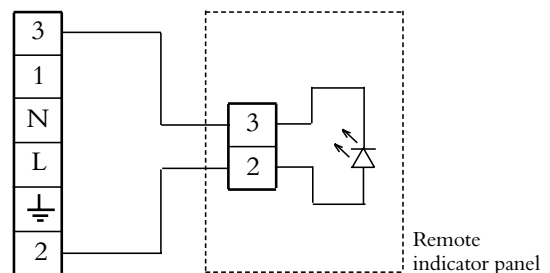

**Wiring details for remote indicator.**

# NUAIRE



## DECLARATION OF CONFORMITY

NuAire Limited,  
Western Industrial Estate, Caerphilly, Mid  
Glamorgan, CF83 1XH.  
United Kingdom.  
Telephone: 02920 885911  
Fax: 02920 887033  
Email: info @ nuaire.co.uk  
www.nuaire.co.uk

MARCH 2000



*We declare that the machine named below  
conforms to the requirements of EC Council Directives  
relating to Electromagnetic Compatibility and  
Safety of Electrical Equipment.*

---

<b>Designation of machinery :-</b>	OPUS 12V EXTRACT FANS
<b>Machinery Types :-</b>	OPUS 30 12V ('R' RANGE)
<b>Relevant EC Council Directives :-</b>	89/336/EEC, 92/31/EEC (EMC) 73/23/EEC, 93/68/EEC (Low Voltage Directive)
<b>Applied Harmonised Standards :-</b>	E50081-1, EN50082-1, EN60204-1 EN60335-2-80
<b>Basis of Self Attestation :-</b>	Quality Assurance to BS EN ISO 9001 BSI Registered Firm Certificate No. FM 149

---

**Signature of manufacture representatives :-**

	<b>Name:</b>	<b>Position:</b>	<b>Date:</b>
1)	 C. Biggs	Technical Director	3. 3. 00
2)	 W. Glover	Manufacturing Director	3. 3. 00

### Maintenance

#### General

It is inevitable that some dust, fluff etc. will pass through the filters, and which, if allowed, will build up internally on motors and impellers, shortening the life of the unit and, in severe cases, leading to overheating of the motors.

Consequently, it is strongly recommended that all units are inspected and cleaned every six months. To clean the filters, remove them from the unit, wash in tepid water to which a little mild detergent has been added. Shake out excess water and allow to dry naturally. Replace when dry.

#### Isolation

Ensure that the unit is totally isolated from the electrical supply. This is particularly important when dealing with a run-on circuit (letter S in the Model Code).

**THE INPUT SOCKET TERMINALS WITHIN THIS UNIT REMAIN LIVE, EVEN WHEN THE ROOM LIGHT OR OTHER ACTUATING SWITCH IS OFF.** Take care therefore when working within the case with the fan module removed.

#### Procedure

At all times, take care not to damage, distort or disturb the balance of the impellers. Remove the cover and then the fan module after releasing the spring clips. Inspect all parts.

With a brush or dry cloth clean the backplate. Lightly brush away dust and dirt from the fan module.

If stubborn, carefully remove with a suitable blade or scraper. Wash the cover in warm soapy water. Dry thoroughly. Refit the fan module, followed by the cover.

Test/run.

#### Adjusting the run-on timer.

Remove cover. Locate the Time Delay Adjustment at the plastic box integral with the fan module. Re-set against the graduated scale. Re-fit the cover.

#### Warranty

The plastic control box integral with the fan assembly is a sealed component. Breaking the plastic sealing tie will invalidate the guarantee. The unit is guaranteed for a period of 3 years.

#### Service

As a manufacturer NuAire provides you with factory trained Service Engineers.

Our Engineers are supported by a comprehensive range of spare parts 'off the shelf'.

If you are an industrial or commercial user, you may be interested in details of NuAire's regular maintenance Service Contracts. This is a worthwhile service that helps you get the most from our products.

Our Service Department will be happy to give you more information.

Please telephone: 029 2085 8585

#### Controls Application Service (CAS)

A team of Engineers and technicians is available to provide pre and post order support.

We are on hand to provide help and advice from the most basic use of any NuAire equipment to the more complex applications, maximising on the versatility of our SMART and NetLink control products.

Telephone: 029 2085 8585

Facsimile: 029 2085 8586

#### 3 Year Warranty

The three year warranty starts from the date of delivery and includes parts and labour for the first year.

The labour element is subject to full, free and safe access to the equipment as recommended by the CDM regulations.

The remaining two years covers replacement parts only.

#### NOTE:

**Installation & Maintenance of the equipment must be as directed in the instructions provided with the unit.**

*Technical or commercial considerations may, from time to time, make it necessary to alter the design, performance and dimensions of equipment and the right is reserved to make such changes without prior notice.*

# NUAIRE

Western Industrial Estate, Caerphilly,  
Mid Glam CF83 1XH United Kingdom.  
Telephone: 029 2088 5911 Facsimile: 029 2088 7033,  
Email: [info@nuaire.co.uk](mailto:info@nuaire.co.uk)  
[www.nuaire.co.uk](http://www.nuaire.co.uk)

Leaflet No. 670628

NB

If you have any comments or queries on any of our products or services please write to the Product Information Manager at the main address opposite.

GP145