

DAVE Extract (DE) Fans

For Internal & External Use

Installation and Maintenance

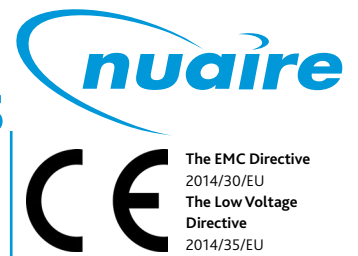

1.0 INTRODUCTION

DAVE Extract Fans

The Dave range of in-line backward curve fans consists of 9 sizes with a maximum duty of 1.1m³/s (1100l/s).

Units are manufactured from aluzinc, rectangular in section and have circular rigid spigots at each end. All units are supplied with fixing brackets designed to simplify installation.

CODE DESCRIPTION:

DE 2 HA - ES
| | | | |
1 2 3 4 5

1. DAVE Range
2. Extract Fan
3. Unit Size: 1 - 7
4. Fan / Case Type: No Reference = Standard Fan / Case
A = Extended Case (Includes G3 Filter)
H = High Pressure Fan (Size 2 & 4 only)
HA = High Pressure Fan (Size 2 & 4 only) with Extended Case (Includes G3 Filter)
5. Heater N = No Heater
L = LPHW
E = Electric
6. Control type: ES = Ecosmart Classic
7. Electrical Frequency: No Reference = 50 Hz
H = 60 Hz

2.0 DELIVERY & RECEIPT OF EQUIPMENT

All equipment is inspected prior to despatch and leaves the factory in good condition. Upon receipt of the equipment an inspection should be made and any damage indicated on the delivery note.

Particulars of damage and/or incomplete delivery should be endorsed by the driver delivering the goods before offloading by the purchaser.

No responsibility will be accepted for damage sustained during the offloading from the vehicle or on the site thereafter.

All claims for damage and/or incomplete delivery must be reported to Nuaire within two days of receipt of the equipment.

2.1 Offloading & Handling

The weight of the unit modules and palletised items are displayed on the packaging.

Some of the modules have an uneven weight distribution, and this will be indicated by labelling where appropriate.

Offloading and positioning of the equipment is the responsibility of the purchaser. Items should only be lifted by competent personnel following appropriate risk assessment.

IMPORTANT

Service / Maintenance Access – Unit must be installed with a minimum of unit depth as additional clearance i.e. DS1A-NES either allow 233mm above or below unit.

Figure 1. Typical Lifting methods.

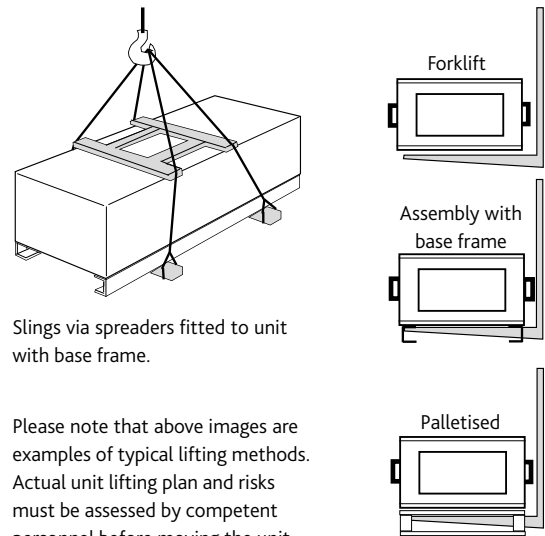

Slings via spreaders fitted to unit with base frame.

Please note that above images are examples of typical lifting methods. Actual unit lifting plan and risks must be assessed by competent personnel before moving the unit.

3.0 INSTALLATION

Installation must be carried out by competent personnel, in accordance with good industry practice, the appropriate authority and in conformance with all statutory and governing regulations.

Access to the unit for maintenance is via the top or bottom lid, this should be taken into account before installation takes place (see important note).

Dave extract fans can be installed in any orientation. Units are supplied complete with four support mounting brackets for quick and easy installation, either surface mounted or suspended with drop rods.

Figure 2. Units supplied with four mounting brackets with 1 x M8 hole in each.

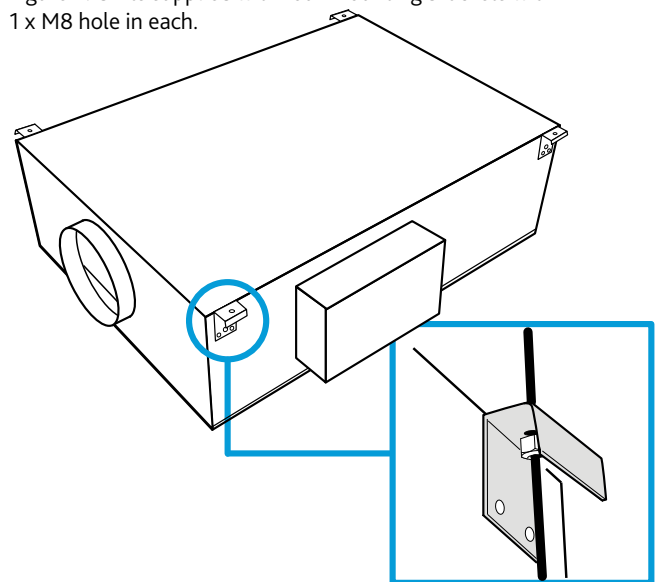

4.0 DIMENSIONS (mm) & WEIGHTS (Kg)

4.1 Dimensions (mm) - Extract Fans with Standard Case

Unit Code	A	B	C	'D' Dia.	G	H	J	K	L
DE1-ES(H)	605	559	233	150	370	150	100	560	609
DE2-ES(H)	605	696	300	200	370	150	100	560	746
DE2H-ES(H)	605	696	300	200	370	150	100	560	746
DE3-ES(H)	605	780	345	200	370	150	100	560	830
DE4-ES(H)	605	840	370	250	370	150	100	560	890
DE4H-ES(H)	605	840	370	250	370	150	100	560	890
DE5-ES(H)	605	984	410	315	370	150	100	560	1034
DE6-ES(H)	605	1092	455	400	370	150	100	560	1142
DE7-ES(H)	605	1200	500	400	370	150	100	560	1250

Figure 3. Extract fan with standard case dimensions.

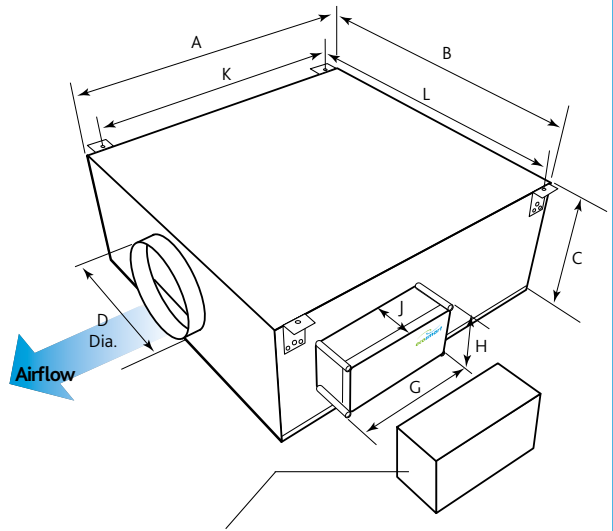

Removable weatherproof control cover dimensions:
DE1 to DE7-ES 470mm W x 173mm H x 120mm D

4.2 Dimensions (mm) - Extract Fans with Extended Case (A)

Unit Code	A	B	C	'D' Dia.	G	H	J	K	L
DE1A-ES(H)	1005	559	233	150	370	150	100	960	609
DE2A-ES(H)	1005	696	300	200	370	150	100	960	746
DE2HA-ES(H)	1005	696	300	200	370	150	100	960	746
DE3A-ES(H)	1005	780	345	200	370	150	100	960	830
DE4A-ES(H)	1005	840	370	250	370	150	100	960	890
DE4HA-ES(H)	1005	840	370	250	370	150	100	960	890
DE5A-ES(H)	1005	984	410	315	370	150	100	960	1034
DE6A-ES(H)	1005	1092	455	400	370	150	100	960	1142
DE7A-ES(H)	1005	1200	500	400	370	150	100	960	1250

Figure 4. Extract fan with extended case 'A' dimensions.

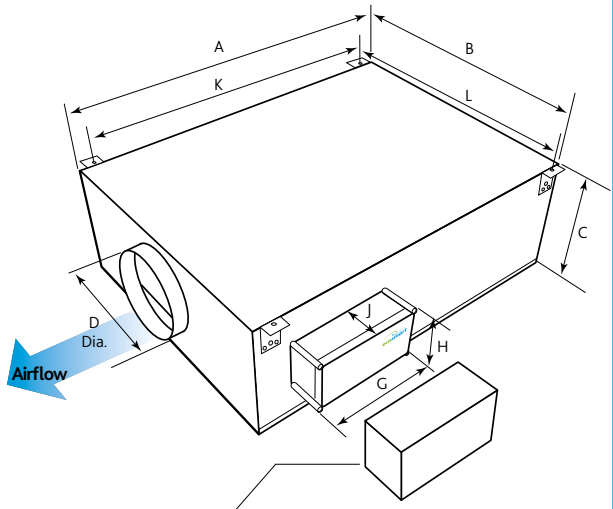

Removable weatherproof control cover dimensions:
DE1A to DE7A-ES 470mm W x 173mm H x 120mm D

4.3 Weights (Kg) - Supply Fans

Unit Code	Weight	Unit Code	Weight
DE1-ES(H)	25	DE5-ES(H)	59
DE1A-ES(H)	30	DE5A-ES(H)	70
DE2-ES(H)	25	DE6-ES(H)	69
DE2A-ES(H)	40	DE6A-ES(H)	75
DE2H-ES(H)	25	DE7-ES(H)	82
DE2HA-ES(H)	45	DE7A-ES(H)	90
DE3-ES(H)	30		
DE3A-ES(H)	50		
DE4-ES(H)	35		
DE4A-ES(H)	67		
DE4H-ES(H)	40		
DE4HA-ES(H)	67		

5.0 ELECTRICAL CONNECTION

5.1 Wiring Connections for Units With Ecosmart Control

Unit details including Full Load Current, Voltage, fan speed etc. can be found on the unit label.

5.1.1 Mains Connections

Mains cables should be suitably sized and terminated at the terminals shown on the appropriate diagram.

5.1.2 Control Connections

3 IDC plug-in Net connectors are provided for the connection of compatible sensors, manual controls and for linking the fans together under a common control. If more than 3 connections are required, the junction box (product code ES-JB) should be used (see data cable installation).

Figure 5. 'Net' connection for Ecosmart devices.

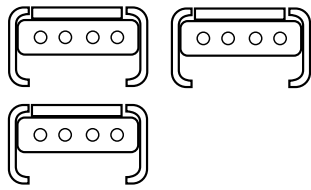

5.1.3 Switched Live (SL) Terminal

Mains cables should be suitably sized and terminated at the terminals shown on the appropriate diagram.

5.1.4 Control Connections

A signal of 100-230V / 220V a.c. will activate the fan from either its off state or trickle state (see setting to work-trickle switch). When the SL is disconnected the fan will over-run (see setting to work-timer adjustment).

Do not take this signal from an isolating transformer.

Figure 6. SL terminal.

Remove link if switched live signal, an enabler or BMS signal is connected.

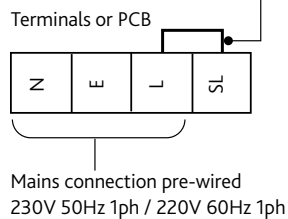

5.1.5 Volt Free Relay Contacts

Volt free contacts are not fused, if these are used to power any external equipment, the installer must provide adequate fusing or other protection. These contacts are rated at 5A resistive, 0.5A inductive.

Figure 7. Volt free relay contacts.

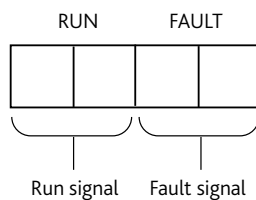

Run Connections = Contacts are closed when the fan is running.

Fault Connections - No Fault = Contacts are closed.

Fault Connections - Fault = Contacts are open.

5.1.6 Data Cable Installation

A 4-core SELV data cable is used to connect devices. Do not run data cable in the same conduit as the mains cables and ensure there is a 50mm separation between the data cable and other cables. The maximum cable run between any two devices is 300m when it is installed in accordance with the instructions.

Please note that the total data cable length used in any system must be less than 1000m. Keep the number of cable joints to a minimum to ensure the best data transmission efficiency between devices.

5.1.7 Maximum Number of Devices

The maximum number of devices (including fans) that can be connected together via the cable is 32, irrespective of their functions.

5.1.8 Other Low Voltage Cables

Follow the basic principle (as 5.1.6). Keep the cable run as short as possible, less than 50 metres.

5.1.9 Commissioning Panel Details

Note: A Commissioning Procedure document (leaflet No. 671153) is available on request from the Nuair Technical Library
Tel: 029 2088 5911.

Figure 8. Commissioning panel.

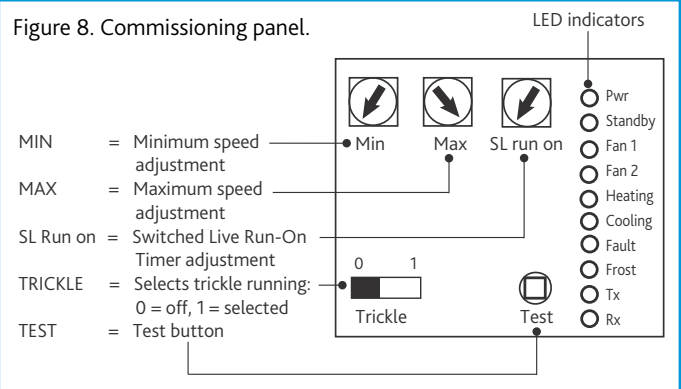

LED indication for units with Ecosmart Control

- PWR** GREEN: Power on & OK.
RED: To much power is taken by peripherals or there is a short circuit in the net cable. Check the cable and use a junction box (ES-JB) to connect some of the peripherals.
- Standby** LED on when fan is not running.
- Fan 1** GREEN: Fan 1 is running, RED: Fan 1 faulty.
- Fan 2** GREEN: Fan 2 is running, RED: Fan 2 faulty (Twinfan only).
- Heating*** Not applicable. See note.
- Cooling*** Not applicable. See note.
- Fault** LED on when a fault is present on unit.
- Frost*** Applicable with LPHW only. See note.
- Tx** LED on when the controller is transmitting data.
- Rx** LED on when the controller is receiving data.

*** Note that the control panel is common to all the Ecosmart classic products and will have indicators for functions that are not available in this particular fan. However these indicators will not be illuminated.**

5.2 Control Module

Figure 9. PCB details.

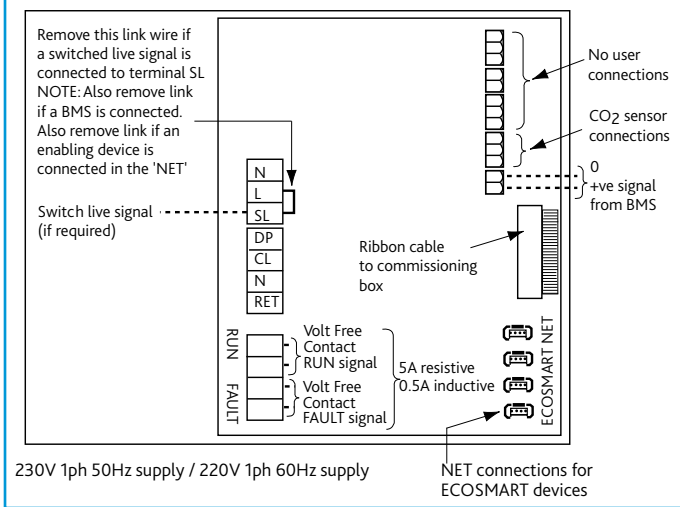

5.2.1 BMS Input Signals

The BMS connection is made with a plug-in connector via the socket (see fig. 10). To ensure the connection is made only by suitably qualified and authorised personnel the plug is not supplied.

Plug-in BMS connector is available from:
R S Components, Part No. 403-875 or
Farnell, Part No. 963-021.

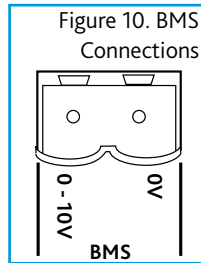

IMPORTANT

Reversal of the BMS connection will damage the control.

End of Page

The system's response to a 0-10V dc BMS signal is given in the table below. **Note the BMS signal will override any sensors and user control connected in the system. The voltage tolerance is +/- 125mV and is measured at the fans terminal.**

	Ventilation	Cooling mode *	Heating mode *
Local Control	0.00	-	-
OFF / Trickle	0.25	-	-
Speed 1	0.50	0.75	1.00
Speed 2	1.50	1.75	2.00
Speed 3	2.50	2.75	3.00
Speed 4	3.50	3.75	4.00
Speed 5	4.50	4.75	5.00
Speed 6	5.50	5.75	6.00
Speed 7	6.50	6.75	7.00
Speed 8	7.50	7.75	8.00
Speed 9	8.50	8.75	9.00
Speed 10	9.50	9.75	10.00

*Only available on relevant unit

IMPORTANT

Isolation - Before commencing work, make sure that the unit and Nuair control are electrically isolated from the mains supply.

6.0 WIRING DIAGRAMS

6.1 DE1-7 with Standard Case (No Filter)

Figure 11. DE1-7 with standard case.

Note: Local isolator (by others)
All inter-connections between circuit boards, blowers and sensors are made at the factory. Remove link wire if switched live signal, an enabler or BMS signal is connected.

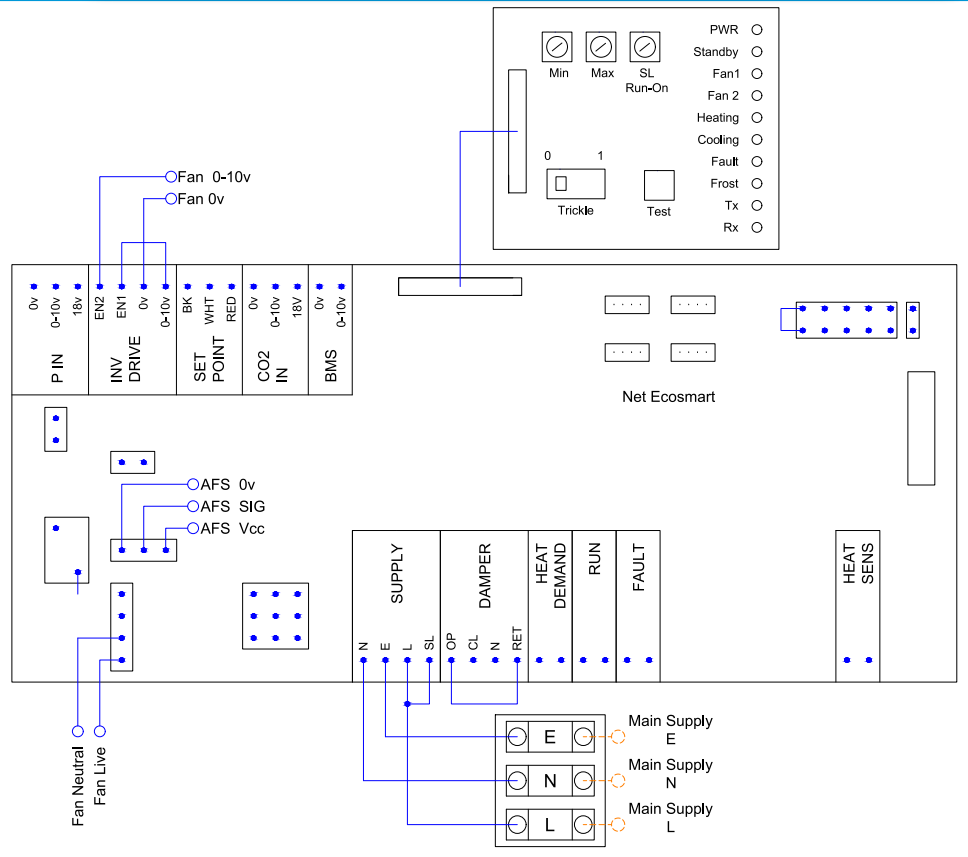

6.2 DE1-7 with Extended Case (G3 Filter)

Figure 12. DE1-7 with extended case.

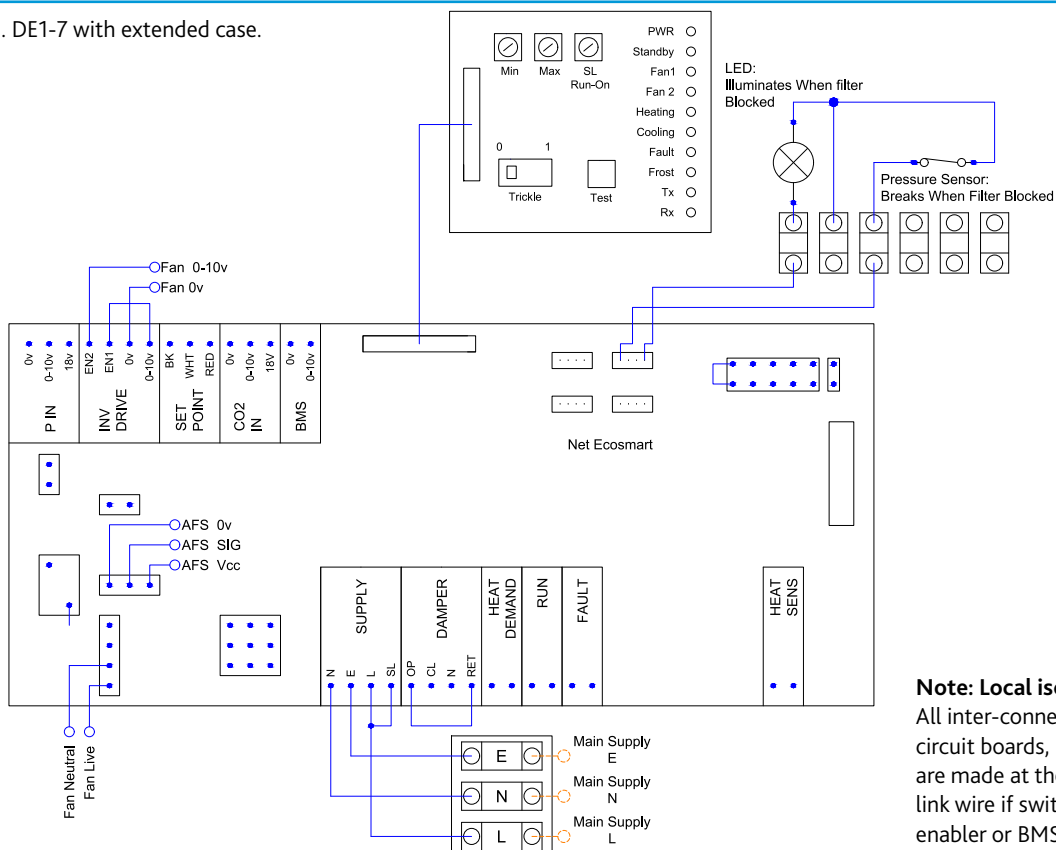

Note: Local isolator (by others)
All inter-connections between circuit boards, blowers and sensors are made at the factory. Remove link wire if switched live signal, an enabler or BMS signal is connected.

7.0 MAINTENANCE

The first maintenance should be carried out three months after commissioning and thereafter at 12 monthly intervals.

General Cleaning and inspection - Electrically isolate before commencing work. Remove the top or the bottom cover and carefully clean out the interior as necessary. Check all parts for security and that the impeller rotates freely, taking care not to disturb the balance. Ensure all control components are secure and clean, refit the cover.

Lubrication - Motors are fitted with sealed for life bearings and do not require any lubrication.

Filter care/replacement - The filter (where applicable) will require cleaning on a regular basis. The frequency of the cleaning operation will depend on the site conditions.

7.1 Dirty Filter Alarm ('A' models with extended case only)

Units pre fitted with a panel air filter are equipped with an visual Red LED alarm on the side of the control. The pressure switch is pre set at 150pa and positioned within the unit and accessed via the removable top or bottom panel. If required, the alarm signal can be positioned to another area by others using the pre fitted terminal block - A volt free relay must be used between the controll and customer wiring.

LED On – Pressure exceeds the maximum allowable final pressure drop.

Replacement filter part numbers are given in section 10.1.

8.0 FAN COMPONENTS

Figure 13. Fan components (no heater).

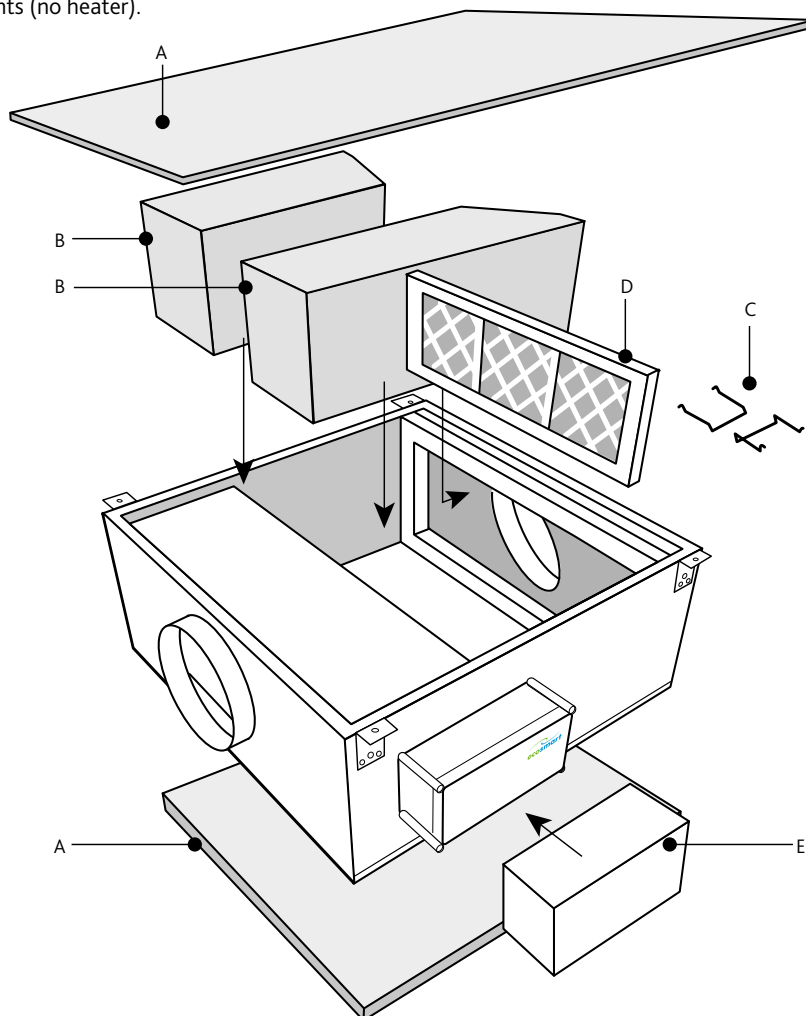

Key	Components
A	Lid / Base
B	Attenuation Pods ('A' models with extended case only)
C	Attenuation Pods Retaining Clips ('A' models only)
D	G3 Filter ('A' models with extended case only)
E	Weather Cover for External Control Box Installation (If required)

9.0 WARRANTY

5 year warranty on Ecosmart models for peace of mind. The warranty starts from the day of delivery and includes parts and labour for the first year. The remaining period covers replacement parts only.

This warranty is void if the equipment is modified without authorisation, is incorrectly applied, misused, disassembled, or not installed, commissioned and maintained in accordance with the details contained in this manual and general good practice.

The product warranty applies to the UK mainland and in accordance with Clause 14 of our Conditions of Sale. Customers purchasing from outside of the UK should contact Nuaire International Sales office for further details.

10.0 AFTER SALES

For technical assistance or further product information, including spare parts and replacement components, please contact the After Sales Department.

10.1 G3 Filter Replacement ('A' models with extended case only)

Unit	Replacement Part Number
DE1A-ES	D1A-G3FILTERKIT
DE2A-ES	D2A-G3FILTERKIT
DE2HA-ES	D2HA-G3FILTERKIT
DE3A-ES	D3A-G3FILTERKIT
DE4A-ES	D3A-G3FILTERKIT
DE4HA-ES	D4HA-G3FILTERKIT
DE5A-ES	D5A-G3FILTERKIT
DE6A-ES	D6A-G3FILTERKIT
DE7A-ES	D7A-G3FILTERKIT

Telephone 02920 858 400
aftersales@nuair.co.uk

DECLARATION OF INCORPORATION AND INFORMATION FOR SAFE INSTALLATION, OPERATION AND MAINTENANCE

We declare that the machinery named below is intended to be assembled with other components to constitute a system of machinery. All parts except for moving parts requiring the correct installation of safety guards comply with the essential requirements of the Machinery Directive. The machinery shall not be put into service until the system has been declared to be in conformity with the provisions of the EC Machinery Directive.

Designation of machinery: DAVE Ecosmart (ES) models
Machinery Types: Extract fans
Relevant EC Council Directives: 2006/42/EC (Machinery Directive)
Applied Harmonised Standards: BS EN ISO 12100, BS EN ISO 13857 EN60204-1, BS EN ISO 9001
Applied National Standards: BS848 Parts 1, 2,2 and 5

Signature of manufacture representatives:

Name:	Position:	Date:
1) C. Biggs 	Technical Director	28. 01. 15
2) A. Jones 	Manufacturing Director	28. 01. 15

Note: All standards used were current and valid at the date of signature.

INFORMATION FOR SAFE INSTALLATION, OPERATION AND MAINTENANCE OF NUAIRE VENTILATION EQUIPMENT

To comply with EC Council Directives 2006/42/EC Machinery Directive and 2014/30/EU (EMC).
 To be read in conjunction with the relevant product documentation (see 2.1)

1.0 GENERAL

1.1 The equipment referred to in this Declaration of Incorporation is supplied by Nuairé to be assembled into a ventilation system which may or may not include additional components.
 The entire system must be considered for safety purposes and it is the responsibility of the installer to ensure that all of the equipment is installed in compliance with the manufacturers recommendations and with due regard to current legislation and codes of practice.

2.0 INFORMATION SUPPLIED WITH THE EQUIPMENT

2.1 Each item of equipment is supplied with a set of documentation which provides the information required for the safe installation and maintenance of the equipment. This may be in the form of a Data sheet and/or Installation and Maintenance instruction. Each unit has a rating plate attached to its outer casing. The rating plate provides essential data relating to the equipment such as serial number, unit code and electrical data. Any further data that may be required will be found in the documentation. If any item is unclear or more information is required, contact Nuairé.
 2.2 Where warning labels or notices are attached to the unit the instructions given must be adhered to.

3.0 TRANSPORTATION, HANDLING AND STORAGE

3.1 Care must be taken at all times to prevent damage to the equipment. Note that shock to the unit may result in the balance of the impeller being affected.
 3.2 When handling the equipment, care should be taken with corners and edges and that the weight distribution within the unit is considered. Lifting gear such as slings or ropes must be arranged so as not to bear on the casing.
 3.3 Equipment stored on site prior to installation should be protected from the weather and steps taken to prevent ingress of contaminants.

4.0 OPERATIONAL LIMITS

4.1 It is important that the specified operational limits for the equipment are adhered to e.g. operational air temperature, air borne contaminants and unit orientation.
 4.2 Where installation accessories are supplied with the specified equipment e.g. wall mounting brackets. They are to be used to support the equipment only. Other system components must have separate provision for support.
 4.3 Flanges and connection spigots are provided for the purpose of joining to duct work systems. They must not be used to support the ductwork.
 4.4 **Local Environment - Humidity.** Ambient humidity (the humidity at the unit's installed location) shall be within the range: 10 to 95% (for controls, non-condensing).
 Air humidity (the humidity of the air passing through the unit) shall be within the range: 10 to 95% (for controls, non-condensing).

5.0 INSTALLATION REQUIREMENTS

In addition to the particular requirements given for the individual product, the following general requirements should be noted.
 5.1 Where access to any part of equipment which moves, or can become electrically live are not prevented by the equipment panels or by fixed installation detail (e.g. ducting), then guarding to the appropriate standard must be fitted.
 5.2 The electrical installation of the equipment must comply with the requirements of the relevant local electrical safety regulations.
 5.3 For EMC all control and sensor cables should not be placed within 50mm or on the same metal cable tray as 230V switched live, lighting or power cables and any cables not intended for use with this product.

6.0 COMMISSIONING REQUIREMENTS

6.1 General pre-commissioning checks relevant to safe operation consist of the following:
 Ensure that no foreign bodies are present within the fan or casing.
 Check electrical safety. e.g. Insulation and earthing.
 Check guarding of system.
 Check operation of Isolators/Controls.
 Check fastenings for security.
 6.2 Other commissioning requirements are given in the relevant product documentation.

7.0 OPERATIONAL REQUIREMENTS

7.1 Equipment access panels must be in place at all times during operation of the unit, and must be secured with the original fastenings.
 7.2 If failure of the equipment occurs or is suspected then it should be taken out of service until a competent person can effect repair or examination. (Note that certain ranges of equipment are designed to detect and compensate for fan failure).

8.0 MAINTENANCE REQUIREMENTS

8.1 Specific maintenance requirements are given in the relevant product documentation.
 8.2 It is important that the correct tools are used for the various tasks required.
 8.3 If the access panels are to be removed for any reason the electrical supply to the unit must be isolated.
 8.4 A minimum period of two minutes should be allowed after electrical disconnection before access panels are removed. This will allow the impeller to come to rest.
NB: Care should still be taken however since airflow generated at some other point in the system can cause the impeller to "windmill" even when power is not present.
 8.5 Care should be taken when removing and storing access panels in windy conditions.

Technical or commercial considerations may, from time to time, make it necessary to alter the design, performance and dimensions of equipment and the right is reserved to make such changes without prior notice.