

Twin Squif - SQFT

High Temperature 400°C for 2 hr

In-line Fans 50 / 60 Hz

Installation and Maintenance



1.0 INTRODUCTION

The Twin Squif fan range is designed for in-duct application. Manufactured from galvanised sheet steel, they are suitable for indoor and outdoor installation. They can be installed with the airflow discharging horizontal or vertically upward. Backdraught dampers are fitted to prevent internal recirculation.

Operating range: 0°C to 90°C; up to 100% RH within the duct; please note the motor must be located in ambient temperature between -10°C to 40°C.

When conveying moisture laden air, provisions must be made to drain off any condensate from within the duct work.

Basic versions of the fan are supplied without any controls. It is the responsibility of the specifier and/or contractor to provide a suitable control for the fan and fan failure detection.

The units are designed for:

S1 DUTY - Day to day operation and in the event of fire a one off emergency use.

4.0 HANDLING

Handle the unit with care and note the weight of the unit.

Always lift the unit by attaching the sling to the motor mounting arms and load spreaders must be used to prevent distortion to the fan case.

Figure 3. Lifting with a load spreader.

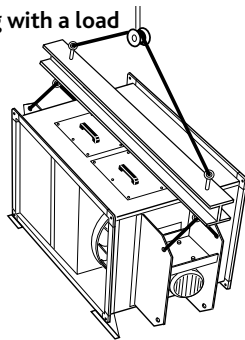

3.0 INSTALLATION AND GENERAL ADVICE

Installation must be carried out by competent personnel, in accordance with good industry practice, the appropriate authority and in conformance with all statutory and governing regulations e.g. IEE, CIBSE, HVCA, BSI and EN standards etc.

Before commencing installation check that all material, including mounting feet and optional ancillaries are available to complete the work. Every unit is tested and serialised at works and a test certificate produced, the details are also recorded on the fan side rating plate which should also be referred to before handling and installation. Any damages or deviations should be immediately reported to the seller/supplier/agent quoting the order number and rating plate details.

2.0 MECHANICAL INSTALLATION

The fans are suitable for both indoor and outdoor installation. Note that any control must be wall mounted in both indoor and outdoor situations.

The fans can be mounted with the airflow discharging horizontally or vertically upward (see table page 2). These units contain heavy rotating parts, please ensure any framework and structure can adequately support the weight of the unit. Do not use the flanges of the fan to support the weight of the ductwork; these must be supported separately.

The ducting must be the same dimension as the fan for at least 1m at the discharge of the fan before any transition. This is to allow the free movement of the dampers and to minimise pressure losses. We recommend the use of anti-vibration mounts to minimise the transmission of vibration into the building structure.

Figure 1. AV mounts fitted to unit mounting feet (supplied) in horizontal discharge mode.

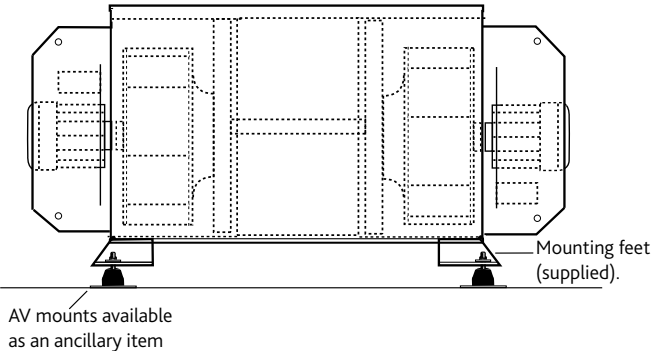
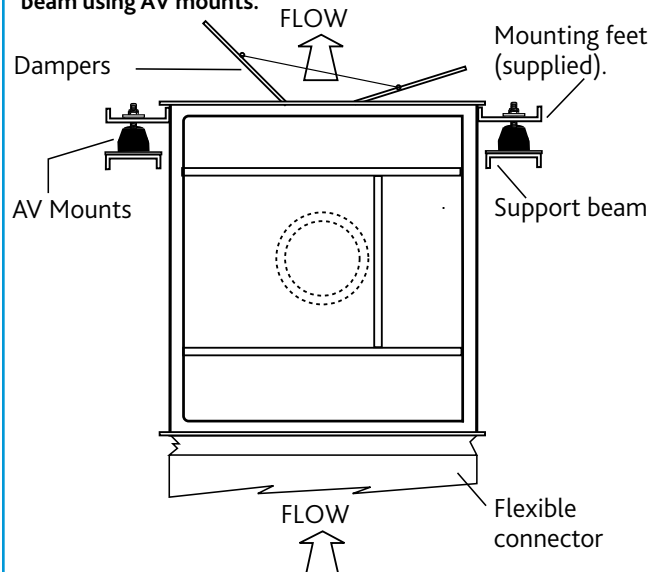

Figure 2. Unit in vertical discharge mode, mounted on support beam using AV mounts.



Rotate the fan impeller by hand to ensure free and smooth rotation and that no handling or transit damage has occurred, observe the direction of flow/direction of rotation arrow and ensure that:

- All optional accessories such as support brackets, attenuators, guards, flexible connectors etc. are assembled to the fan.
- Support brackets are fitted appropriate for the installed attitude - vertical or horizontal.
- When offering the fan to the ducted system that both inlet and outlet connections are perfectly aligned.

It is advisable to fit flexible connectors on either side of the fan unless there is an open-ended inlet or discharge and the fan should be supported on AV mounts.

The AVs should be levelled off to maximise isolation and the flexible connectors correctly aligned with the fan at the correct tension.

IMPORTANT

AV mounts isolate the fan only. Silencers and other "significant mass" accessories should form part of the fixed ductwork after the flexible connection.

5.0 ELECTRICAL INSTALLATION AND WIRING - GENERAL

IMPORTANT

Isolation - Before commencing any installation or maintenance work make sure that the unit is electrically isolated from the mains supply.

All installation work must be planned and carried out by consideration all relevant regulations including CDM, health and safety and wiring regulations.

Ensure the electrical supply is suitable for the fan and is suitably protected by correctly selected fuses or MCB.

For 3 phase units, the electrical connections are made directly onto the terminal boxes of the motors.

For single phase units, the electrical connections are made at termination boxes at the motor mounting brackets.

Note that 3 phase motors up to 3kW (inclusive) must be wired in STAR. Motors of 4kW and above must have DELTA as the final connection arrangement (see page 2 for motor ratings).

6.0 ELECTRICAL INSTALLATION AND WIRING - BASIC UNITS

These units are not supplied with any control or isolators, their selection and provision is the responsibility of the specifier/contractor.

Figure 4. Single Phase Fans - Constant Speed.

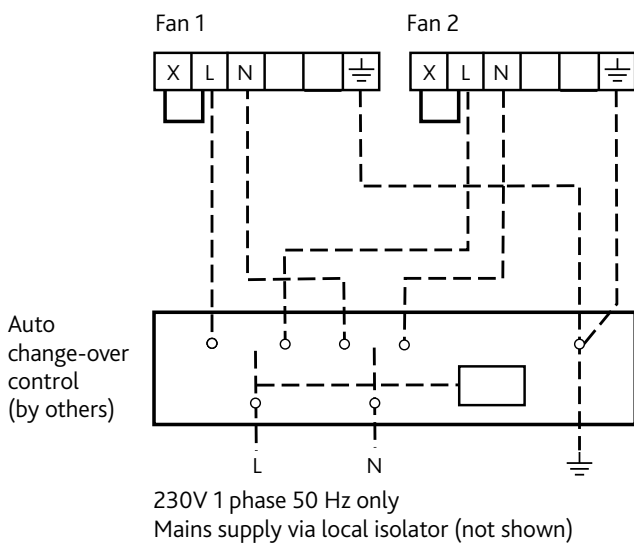

IMPORTANT

When the unit is operated in emergency mode smoke extract operation - all controls must be bypassed.

Figure 5. Three phase fans Single speed - motors up to 3kW inclusive.

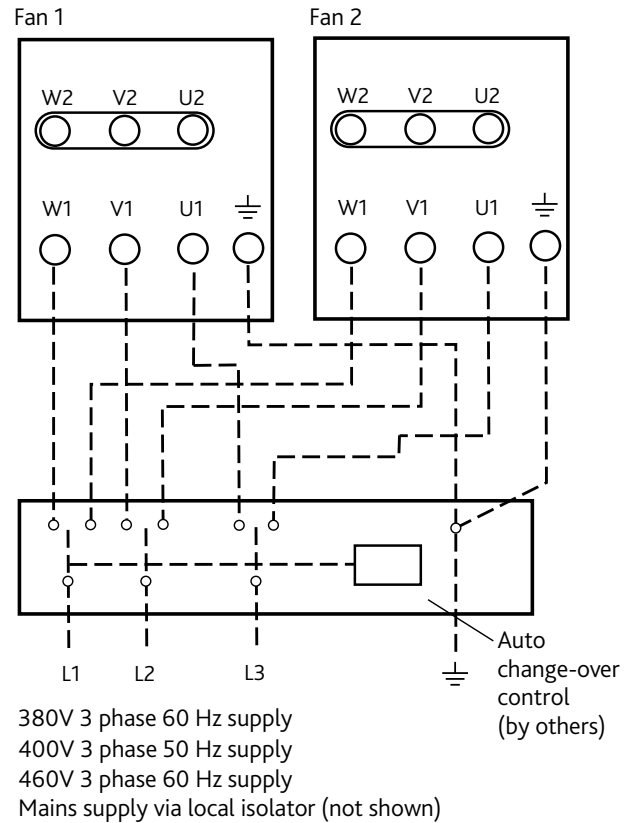
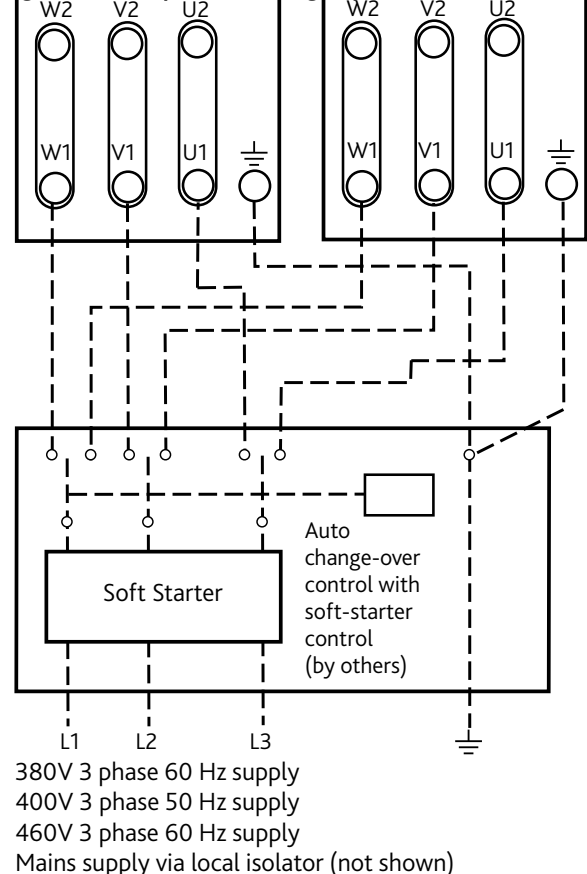

Figure 6. Three phase fans Single speed - motors 4kW or above.



7.0 SPECIFIC COMMISSIONING AND SERVICING REQUIREMENTS

400°C for 2 hours Motors for Smoke Extract Fans

Exposure temperature/time: 400°C for 2 hours

These motors are used to provide a SAFETY FUNCTION for people in the event of fire in public premises or in the home: they are therefore subject to strict constraints concerning their operating and maintenance.

Operating Constraints

- i. Check on the nameplate that the selected motor corresponds to the maximum exposure temperature and duration.
- ii. Non ventilated motors MUST be placed in the airflow from the driven fan. Ventilated motors can be placed outside the flow.
- iii. AFTER THE MOTOR HAS BEEN SUBJECTED TO ONE EMERGENCY DUTY OPERATION, IT MUST BE REPLACED.
- iv. With variable speed control. Ensure that the maximum speed never exceeds the speed of the motor supplied by the mains and that the delivered power corresponds to the previous definitions. The motor should be equipped with PTC thermistors connected to the protection system during S1 duty and switched off during S2 duty (operation during an emergency).

These qualifications ensure the qualification of the driven fan by the manufacturer.

Maintenance Constraints

Regular service visits must be performed on the installation AT LEAST EVERY 6 MONTHS, incorporating the following checks:

i. Checking the insulation resistance (R>100 MOhms, 500V DC)

- If the drain holes are blocked, open them to eliminate any accumulated condensation.
- If R<100 MOhms, dry the stator in an oven and check the insulation resistance. If the fault persists, replace the stator.
- The stator must be replaced 5 years after installation or after 20,000 hours of operation.

ii. Cooling check

- Ensure there is no dust or grease in the entire ventilation circuit (housing fins, motor cover/fan if fitted driven fan).
- Ensure the motor runs normally when switched on for a few minutes.

iii. Bearing check (C3 or C4 play)

Run the motor during each maintenance visit. When the motor is cold, a high level of noise is caused by the texture of the grease. This does not indicate a bearing fault.

S2 duty only:

The bearings must be replaced by an identical type every 5 years. Ensure the motor runs normally when switched on for a few minutes.

S1 duty and Emergency in S2 duty:

a) Permanently greased bearings.

400°C range; replace on 2 pole motors after 10,000 hours of operation and on motors with 4 poles or more after 20,000 hours.

b) Re-greaseable bearings

The information on the motor nameplates must be strictly respected (grease quantity, grease quality and re-greasing frequency). The bearings must be replaced after 20,000 hours of operation.

8.0 SETTING TO WORK

Ensure that all mechanical and electrical connections and fixings are secure and that inlet and outlet ductwork is free of any obstruction or debris.

Briefly switch the fan on/off to ascertain correct direction of impeller rotation, compare with the rotational label fitted and correct if necessary.

To change the direction of rotation on the 3 phase motor, inter-change any 2 incoming supply phases at the motor terminal box.

Complete the test by running the fan for approximately 15 minutes, taking and comparing voltage, full load and starting currents with the fan rating label. Monitor flexible connections to ensure no leakage and AV mounts for correct alignment.

9.0 MAINTENANCE INTERVALS

The first maintenance should be carried out three months after commissioning and thereafter at twelve monthly intervals. These intervals may need to be shortened if the unit is operating in adverse environmental conditions, or in heavily polluted air.

9.1 Maintenance Check List

ITEM	TICK
Check that safety grilles are secure and free of obstruction.	
Inspect all bolts, fixings and electrical terminals for security.	
Check motor for undue wear, signs of overheating and apply winding insulation and continuity tests.	
Remove all dust and dirt from impellers; be especially careful not to disturb balance weights.	
Generally clean.	
Check resilient mounts (where applicable) and replace any that have any wear or deterioration.	

10.0 LUBRICATION

Motors are fitted with sealed for life bearings and do not require any lubrication.

11.0 GENERAL CLEANING AND INSPECTION

Clean and inspect the exterior of the fan unit and associated controls etc. Remove the access panel from the fan unit. Inspect and, if necessary, clean the fan impeller and motor assemblies and the interior of the case.

Check all parts for security and condition. Check that the impeller rotates freely and the inlet cone and impeller are concentric with a running clearance.

12.0 REPLACEMENT OF PARTS

Because these units are certified to EN12101-3 and complying with the construction products directive, the motor must be returned to the motor manufacturer for replacement.

Any maintenance, repair or bearing replacement on the motor must only be carried out by the motor manufacturer.

Should any further components need replacing, Nuaire keep extensive stocks for quick delivery. Ensure that the unit is electrically isolated, before carrying out any work.

When ordering spare parts, please quote the serial number of the unit and the ARC number of the purchase if possible (**This information will be available on the fan label**).

13.0 WARRANTY

Twin Squif has a 3 year warranty and Ecosmart Twin Squif has a 5 year warranty. The warranty starts from the day of delivery and includes parts and labour for the first year, the remaining years covers replacement parts only.

This warranty is void if the equipment is modified without authorisation, is incorrectly applied, misused, disassembled, or not installed, commissioned and maintained in accordance with the details contained in this manual and general good practice.

The product warranty applies to the UK mainland and in accordance with Clause 14 of our Conditions of Sale. Customers purchasing from outside of the UK should contact Nuaire International Sales office for further details.

14.0 AFTER SALES ENQUIRIES

For technical assistance or further product information, please contact the After Sales Department.

Telephone 02920 858 400
aftersales@nuaire.co.uk

DECLARATION OF INCORPORATION AND INFORMATION FOR SAFE INSTALLATION, OPERATION AND MAINTENANCE

We declare that the machinery named below is intended to be assembled with other components to constitute a system of machinery. All parts except for moving parts requiring the correct installation of safety guards comply with the essential requirements of the Machinery Directive. The machinery shall not be put into service until the system has been declared to be in conformity with the provisions of the EC Machinery Directive.

Designation of machinery: TWIN SQUIF IN-LINE FAN

Machinery Types: SQFT

Relevant EC Council Directives: 2006/42/EC (Machinery Directive)

Applied Harmonised Standards: BS EN ISO 12100-1, BS EN ISO 12100-2, EN60204-1, BS EN ISO 9001, BS EN ISO 13857

Applied National Standards: BS848 Parts 1, 2.2 and 5

Signature of manufacture representatives:

Name:	Position:	Date:
1) C. Biggs 	Technical Director	11.05.11
2) A. Jones 	Manufacturing Director	11.05.11

Note: All standards used were current and valid at the date of signature.

CE DECLARATION OF CONFORMITY

We declare that the machine named below conforms to the requirements of EC Council Directives relating to Electromagnetic Compatibility and Safety of Electrical Equipment.

Designation of machinery: TWIN SQUIF IN-LINE FAN

I & M Serial No.: 671392

Machinery Types: SQFT

Relevant EC Council Directives: 2014/30/EU (EMC), 2014/35/EU (Low Voltage Directive)

Applied Harmonised Standards: EN55014-1, EN55014-2, EN61000-3-2, EN61000-3-3, EN60335-2-80

Basis of Self Attestation: Quality Assurance to BS EN ISO 9001
BSI Registered Firm Certificate No. FM 149

Signature of manufacture representatives:

Name:	Position:	Date:
1) C. Biggs 	Technical Director	11.05.11
2) A. Jones 	Manufacturing Director	11.05.11

Nuaire: A Trading Division of Polypipe,
Western Industrial Estate,
Caerphilly,
CF83 1NA.

Note: All standards used were current and valid at the date of signature.

INFORMATION FOR SAFE INSTALLATION, OPERATION AND MAINTENANCE OF NUAIRE VENTILATION EQUIPMENT

To comply with EC Council Directives 2006/42/EC Machinery Directive and 2014/30/EU (EMC).
To be read in conjunction with the relevant product documentation (see 2.1)

1.0 GENERAL

1.1 The equipment referred to in this Declaration of Incorporation is supplied by Nuaire to be assembled into a ventilation system which may or may not include additional components.
The entire system must be considered for safety purposes and it is the responsibility of the installer to ensure that all of the equipment is installed in compliance with the manufacturers recommendations and with due regard to current legislation and codes of practice.

2.0 INFORMATION SUPPLIED WITH THE EQUIPMENT

2.1 Each item of equipment is supplied with a set of documentation which provides the information required for the safe installation and maintenance of the equipment. This may be in the form of a Data sheet and/or Installation and Maintenance instruction.
2.2 Each unit has a rating plate attached to its outer casing. The rating plate provides essential data relating to the equipment such as serial number, unit code and electrical data. Any further data that may be required will be found in the documentation. If any item is unclear or more information is required, contact Nuaire.
2.3 Where warning labels or notices are attached to the unit the instructions given must be adhered to.

3.0 TRANSPORTATION, HANDLING AND STORAGE

3.1 Care must be taken at all times to prevent damage to the equipment. Note that shock to the unit may result in the balance of the impeller being affected.
3.2 When handling the equipment, care should be taken with corners and edges and that the weight distribution within the unit is considered. Lifting gear such as slings or ropes must be arranged so as not to bear on the casing.
3.3 Equipment stored on site prior to installation should be protected from the weather and steps taken to prevent ingress of contaminants.

4.0 OPERATIONAL LIMITS

4.1 It is important that the specified operational limits for the equipment are adhered to e.g. operational air temperature, air borne contaminants and unit orientation.
4.2 Where installation accessories are supplied with the specified equipment e.g. wall mounting brackets. They are to be used to support the equipment only. Other system components must have separate provision for support.
4.3 Flanges and connection spigots are provided for the purpose of joining to duct work systems. They must not be used to support the ductwork.
4.4 **Local Environment - Humidity.** Ambient humidity (the humidity at the unit's installed location) shall be within the range: 10 to 95% (for controls, non-condensing). Air humidity (the humidity of the air passing through the unit) shall be within the range: 10 to 95% (for controls, non-condensing).

5.0 INSTALLATION REQUIREMENTS

In addition to the particular requirements given for the individual product, the following general requirements should be noted.
5.1 Where access to any part of equipment which moves, or can become electrically live are not prevented by the equipment panels or by fixed installation detail (e.g. ducting), then guarding to the appropriate standard must be fitted.
5.2 The electrical installation of the equipment must comply with the requirements of the relevant local electrical safety regulations.
5.3 For EMC all control and sensor cables should not be placed within 50mm or on the same metal cable tray as 230V switched live, lighting or power cables and any cables not intended for use with this product.

6.0 COMMISSIONING REQUIREMENTS

6.1 General pre-commissioning checks relevant to safe operation consist of the following:
Ensure that no foreign bodies are present within the fan or casing.
Check electrical safety: e.g. Insulation and earthing.
Check guarding of system.
Check operation of Isolators/Controls.
Check fastenings for security.
6.2 Other commissioning requirements are given in the relevant product documentation.

7.0 OPERATIONAL REQUIREMENTS

7.1 Equipment access panels must be in place at all times during operation of the unit, and must be secured with the original fastenings.
7.2 If failure of the equipment occurs or is suspected then it should be taken out of service until a competent person can effect repair or examination. (Note that certain ranges of equipment are designed to detect and compensate for fan failure).

8.0 MAINTENANCE REQUIREMENTS

8.1 Specific maintenance requirements are given in the relevant product documentation.
8.2 It is important that the correct tools are used for the various tasks required.
8.3 If the access panels are to be removed for any reason the electrical supply to the unit must be isolated.
8.4 A minimum period of two minutes should be allowed after electrical disconnection before access panels are removed. This will allow the impeller to come to rest.
NB: Care should still be taken however since airflow generated at some other point in the system can cause the impeller to "windmill" even when power is not present.
8.5 Care should be taken when removing and storing access panels in windy conditions.