



# UNI-X

Supply & Extract Ventilation Unit with Heat Recovery  
Installation and Maintenance Instructions



The EMC Directive  
2014/30/EU  
The Low Voltage  
Directive  
2014/35/EU

## 1.0 SAFETY INFORMATION

- Sharp edges need to be handled with caution. Care should be taken that all personnel are aware of this and precautions are implemented to ensure that no injuries are caused.
- Items should only be lifted by competent personnel following appropriate risk assessment.
- The unit must be installed fully levelled, for the condensate drain and for compliance with safety regulations relating to IP protection for water drip ingress.
- The five core cable from the mains power supply should be connected to a fixed wiring installation, via a fused isolator, in accordance with current IEE wiring regulations.
- The electrical wiring should be carried out by competent persons, in accordance with industry practises and in conformance to all governing and statutory bodies.
- Isolation - Before commencing work make sure that the unit, switched live and Nuaire control are electrically isolated from the mains supply and switched live supply.
- The unit must be earthed.
- In the event of an ESD discharge while operating the optional touch switch, the fan control may reset itself causing the fans to switch off temporarily. Functions will resume as normal after the control resets.
- Disconnection from the supply mains must be incorporated within the fixed wiring in accordance with the wiring regulations and shall have a minimum contact separation of 3mm.
- The supply cable must be replaced by an electrically competent person.

## 2.0 INTRODUCTION

The UNI-X ceiling void unit range is designed to provide mechanical supply and extract ventilation with heat recovery, which incorporates an automatic HX bypass feature.

The units are fitted with two high efficiency centrifugal fans with EC Motors, which have speed control over three different ventilation rates; trickle, boost and max. A counterflow plate heat exchanger is also used to recover up to 85% of the extracted air heat, whilst G3 Filters provide protection to the unit and ensure filtered air is supplied, guaranteeing the unit is ErP 2018 compliant.

The HX bypass damper shall open automatically via a wax actuator allowing the air to bypass the heat exchanger to deliver fresh filtered air during the warmer months.

General information regarding performance and specifications for the equipment may be obtained from our Technical Literature, and/or project specific documentation.

CODE DESCRIPTION:		
UNI -X 360 - C		
1	2	3
<b>1. UNIVERSAL X Range</b>		
<b>2. Unit Size:</b>	220, 360, 580	
<b>3. Spigot type:</b>	No Suffix = Rectangular 220x90mm C = Circular 150mm Ø	

## 3.0 HEALTH & SAFETY

Nuair intend that this manual and any other supportive documents that may be mentioned should be read and understood by authorised operating and service personnel before performing any task related to the installation, commissioning and maintenance of a Nuair UNI-X unit and any associated components.

The operative / service personnel should comply with good industry practice, the appropriate authority and conformance with all statutory and governing regulations.

The unit must be manually isolated from the electrical supply and a period of five minutes elapsing before any access to the unit is opened for the purpose of general maintenance.

Sharp edges need to be handled with caution. Care should be taken that all personnel are aware of this and precautions are implemented to ensure that no injuries are caused.

To help operating and service personnel perform tasks safely, please pay attention to the notes throughout this document. **All notes are designed to alert the reader to potential hazards.**

## 4.0 RECEIPT OF GOODS

### 4.1 Delivery

All equipment is inspected prior to despatch and leaves the factory in good condition. Upon receipt of the equipment an inspection should be made and any damage indicated on the delivery note.

Particulars of damage and/or incomplete delivery should be endorsed by the driver delivering the goods before offloading by the purchaser.

No responsibility will be accepted for damage sustained during the offloading from the vehicle or on the site thereafter. All claims for damage and/or incomplete delivery must be reported to Nuair within two days of receipt of the equipment.

### IMPORTANT

The unit must be installed fully levelled, for the condensate drain and for compliance with safety regulations relating to IP protection for water drip ingress.

## 4.2 Offloading

The weight of the unit modules and palletised items are displayed on the packaging.

Some of the modules have an uneven weight distribution, and this will be indicated by labelling where appropriate.

Offloading and positioning of the equipment is the responsibility of the purchaser. Items should only be lifted by competent personnel following appropriate risk assessment.

## 4.3 Handling

Spreaders should be used when lifting with slings to avoid damage to the casings. Care must be taken to ensure that slings are correctly positioned to avoid crushing and twisting of the unit casings.

## 4.4 Unit Protection

Unless otherwise specified, unit sections will be delivered to site covered in "shrink wrap" polythene.

Should alternative methods of unit protection be required (i.e. timber, Corex, or flame retardant materials), Nuair should be notified of the specific requirements at the pre- contract stage. Waste must be disposed of by a registered waste carrier in accordance to national regulations.

## 4.5 Storage

The equipment must be stored in a dry, internal location. Ductwork connection apertures shall be sealed against the ingress of dust, water and vermin. Do not stack units, modules or components.

## 5.0 INSTALLATION

Installation of the UNI-X units, including all external services and controls should be installed in accordance with the appropriate site procedures, and MUST conform to all governing regulations e.g. CDM, CIBSE, IEE, and in strict accordance with the applicable Building Regulations.

The fan must be installed indoors, in a suitable ceiling void away from direct sources of frost, heat and water spray or moisture generation. For a vibration-free result the unit must be mounted to a solid surface in the void.

The unit is designed for ceiling mounting on a horizontal surface and incorporates steel mounting points (fixings are not supplied) in the casing design as well as bottom access for filter replacement.

Offset spigots have been included in the unit for greater flexibility in the layout of the ductwork.

The correct installation position for the units shall be decided with due regard to access and maintenance requirements, and the objective of minimising the system ductwork resistance.

The recommended installation method is to use standard Unistrut channel secured to the slab or steelwork above the unit.

Six suitable drop rods or bolts should be secured to the Unistrut channel and extended to be fixed to the unit's two mounting brackets (one on each side of the unit, each with 3 fixing points).

In the unlikely event of motor failure, the unit must be lowered from its installation position in order to facilitate a motor replacement. An access hatch of sufficient size for the unit to pass through is required. You must ensure that all associated electrical, condensate and ductwork connections can be disconnected.

The unit must be installed with a minimum of 300mm clearance around the control box to allow for maintenance.

**An access hatch of sufficient size for the unit to pass through is required.**

### 5.1 Condensate Drain

Units come complete with external drain pipe (21.5mm waste pipe) at the front of the unit. Use conventional plumbing connections to link up with U-trap or alternative drain method (Solvent cement connections or compression fit connections are recommended). The condensate must be discharged under a water level in a U-trap drainpipe or an alternative drain method which acts as an airlock.

This condensate discharge connection is suitable for 21.5mm diameter overflow pipe. Solvent cement should be used to make the joint.

If using a U-trap please ensure the U-trap has been filled to a suitable level of water to avoid any air locks.

If the condensation pipe is fitted in an unheated space the pipe should be in insulated to prevent freezing.

Ensure that the condensate drain pipe has a minimum 5° fall running to SVP.

**Nuair recommend MVHR-DRAIN be used as the primary condensate take-off.**

#### 5.1.1 MVHR-DRAIN Installation

Offer up the MVHR-DRAIN inlet to the threaded tail of the appliance waste outlet or MVHR-DRAIN knuckle or running adaptor, and tighten the threaded cap sufficiently hand-tight to provide a water-tight seal (check that the cap screws on square and does not 'cross-thread'). When the screwed cap is tight, the MVHR-DRAIN body is secure.

1. Cut the pipe to length, allowing for the full compression socket depth (using an appropriate pipe cutter, such as a Hepworth ratchet pipe cutter).
2. Remove any 'swarf' from the end of the plastic pipe. Ream the copper pipe end to remove any 'burr', and file if necessary to remove any external sharp edges. Mark the socket depth on the pipe, and check that the pipe section to be jointed is free of any surface damage which may affect the joint seal.
3. Unscrew the cap from the MVHR-DRAIN outlet, and slide the cap and rubber seal onto the pipe.
4. Insert the pipe end fully into the socket.
5. Slide the rubber seal and screwed cap up against the face of the socket, and tighten the cap sufficiently hand-tight (check that the cap is square to the body and does not 'cross thread'). Hand tight should be adequate to form a proper seal.

Figure 1. MVHR-DRAIN correct installation

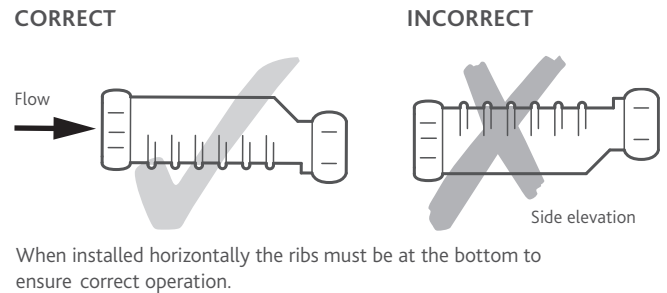

### 5.2 Extract/Input Areas

The unit is designed to extract air from all wet rooms e.g. bathroom, kitchen, en-suite, utility room (with sink). WC's do not need to be ventilated if openable windows are fitted.

Supply air should be to all habitable rooms e.g. bedrooms and lounge. Extract / input grilles should be adjustable valve types (not supplied).

### 5.3 Ducting

It is recommended that rigid ducting should be used at all times. Flexible ducting has a very high resistance and it is impossible to calculate how much resistance will be on a system if used.

If used the flexible ducting must be kept to a minimum and should always be pulled taut. A maximum of 300mm should be used on each leg.

To prevent condensation on the outside of the outside air inlet duct and the air outlet duct from the UNI-X, these ducts should be insulated.

Ducting must be installed in such a way that resistance to airflow is minimised. Bends should be kept to a minimum.

A minimum distance of 300mm between the appliance and any bends in ductwork is recommended. 220 x 90mm rectangular ducting should be used (see Figure 2 for further information).

Ducting joints must be sealed with non-hardening silicone type sealant and needs to be taped with metallised tape. Ducting shall be adequately and reliably fixed to the appliance.

Figure 2. Typical ducting arrangement.

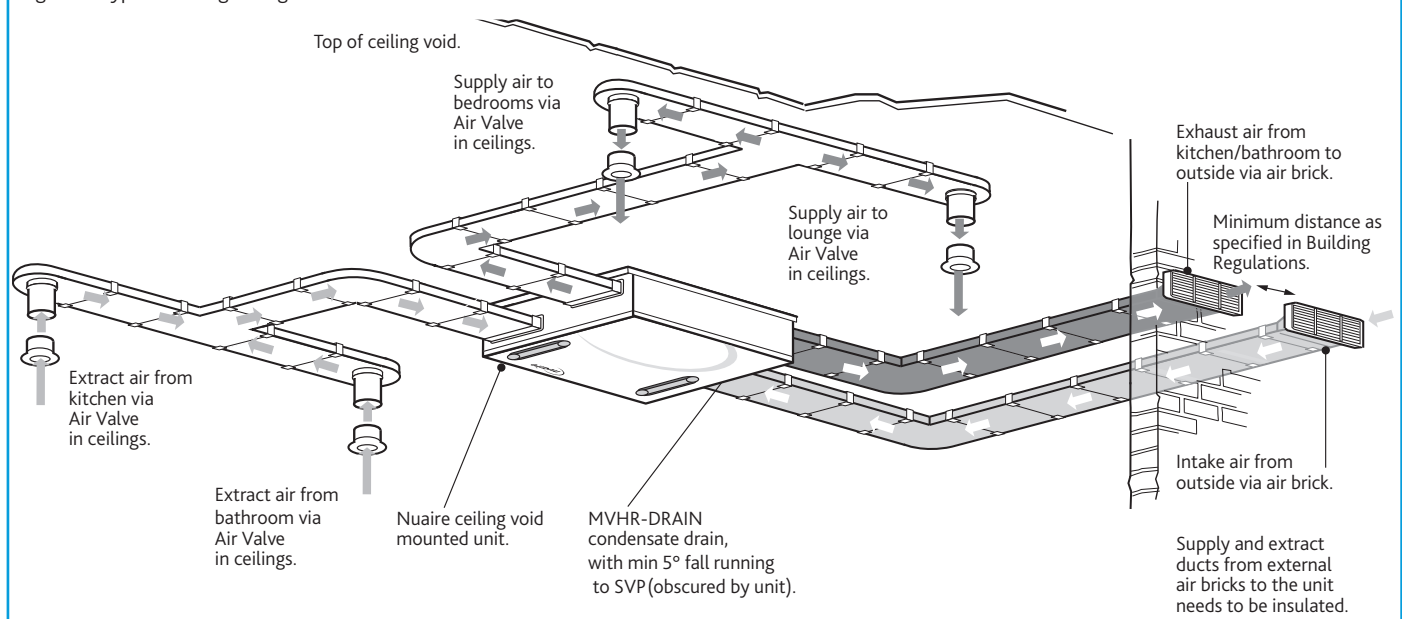

### 6.0 DIMENSIONS

#### 6.1 Units With Rectangular Spigots

Figure 3. Unit dimensions (rectangular spigots).

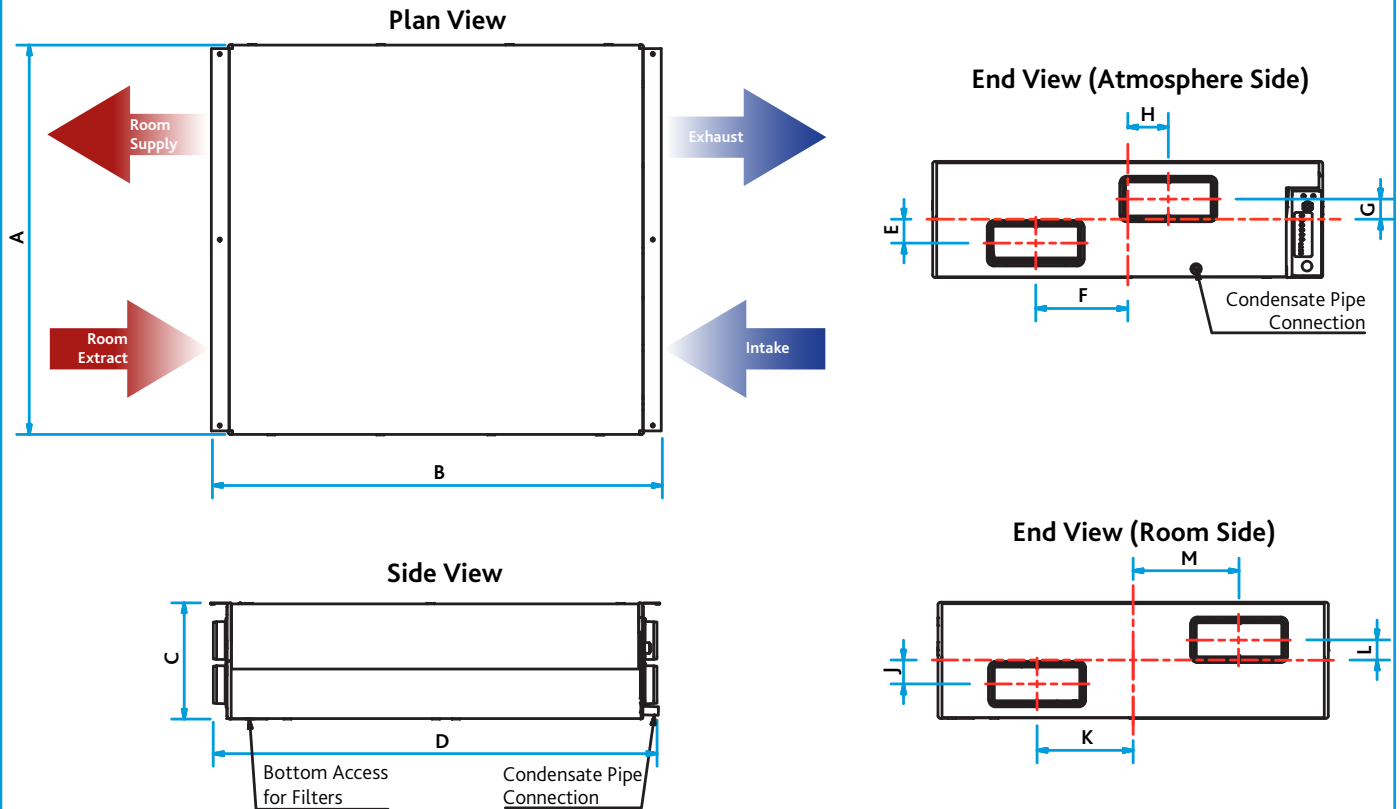

Unit Code	Unit Dimensions (mm)												Unit Weights
	A	B	C	D	E	F	G	H	J	K	L	M	(kg)
UNI-X220	570	980	300	982	71	132	57	142	64	75	57	152	40
UNI-X360	720	1072	300	1100	53	163	53	130	57	160	53	194	55
UNI-X580	985	1136	300	1216	60	233	52	103	60	243	52	268	65

Figure 4. Mounting hole centre dimensions.

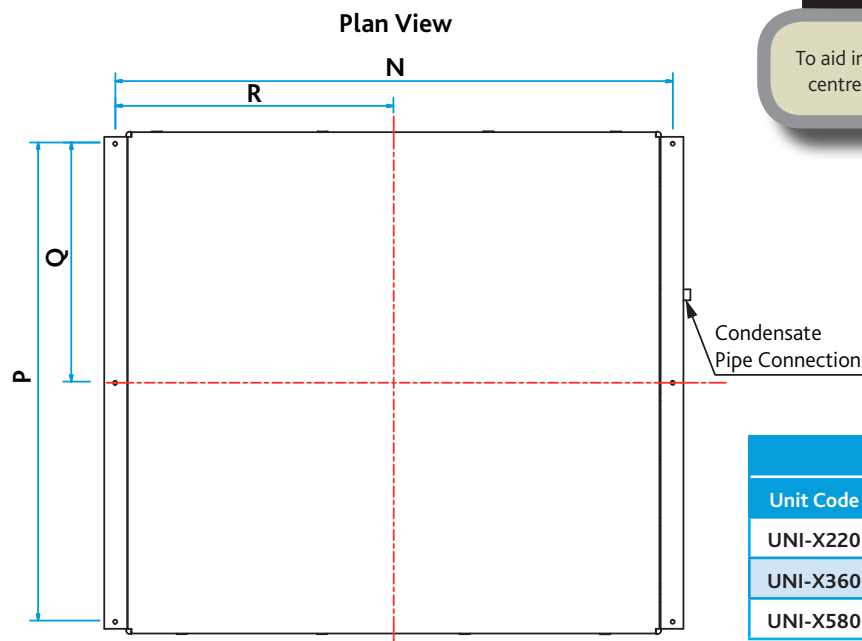

#### IMPORTANT

To aid in installation, dimensional templates including hole centres for mounting points are provided with the units.

Unit Code	Hole Centre Dimensions (mm)			
	N	P	Q	R
UNI-X220	934	524	262	467
UNI-X360	1031	670	335	515
UNI-X580	1091	938	469	546

### 6.2 Units With Circular Spigots

Figure 5. Unit dimensions (circular spigots).

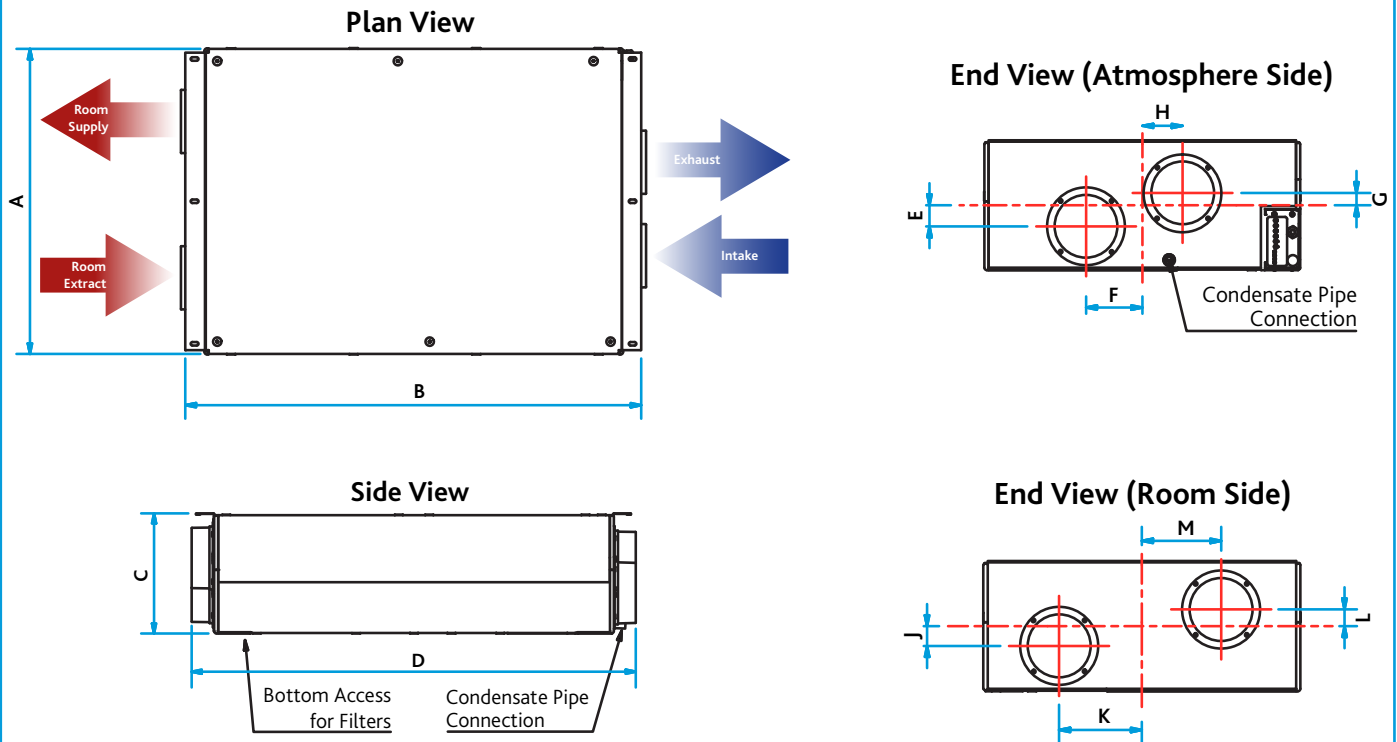

Unit Code	Unit Dimensions (mm)												Unit Weights (kg)
	A	B	C	D	E	F	G	H	J	K	L	M	
UNI-X220-C	570	980	300	982	71	132	57	142	64	75	57	152	40
UNI-X360-C	720	1072	300	1100	53	163	53	130	57	160	53	194	55
UNI-X580-C	985	1136	290	1216	60	233	52	103	60	243	52	268	65

Figure 6. Mounting hole centre dimensions.

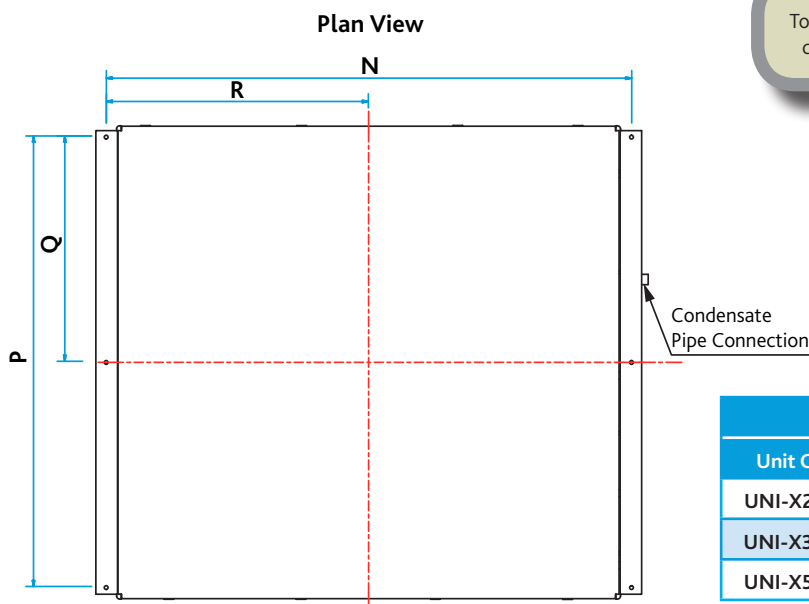

### IMPORTANT

To aid in installation, dimensional templates including hole centres for mounting points are provided with the units.

Unit Code	Hole Centre Dimensions (mm)			
	N	P	Q	R
UNI-X220-C	934	524	262	467
UNI-X360-C	1031	670	335	515
UNI-X580-C	1091	935.6	467.8	546

## 7.0 ELECTRICAL CONNECTION

For good EMC engineering practice, any sensor cables or switched live cables should not be placed within 50mm of other cables or on the same metal cable tray as other cables.

Unit details including Full Load Current, Voltage, fan speed etc. can be found on the unit label.

The UNI-X range of units MUST be earthed.

The five core cable from the mains power supply should be connected to a fixed wiring installation, via a fused isolator, in accordance with current IEE wiring regulations.

### IMPORTANT

The electrical wiring should be carried out by competent persons, in accordance with industry practises and in conformance to all governing and statutory bodies.

### IMPORTANT

In the event of an ESD discharge while operating the optional touch switch, the fan control may reset itself causing the fans to switch off temporarily. Functions will resume as normal after the control resets.

## 7.1 Control Ancillaries

The following list of control ancillary items are available for use with UNI-X units:

- **MRXBOX95-3SWITCH** - 3 speed switch for simple control and commissioning.
- **UNI-X-TT / UNI-X-BT** - Boost switches.
- **230-PIR** - 230V Passive Infra Red (PIR) movement sensor.
- **ES-PIR2** - Ecosmart PIR sensor incorporating system status LED, overrun timer and timer adjustment.
- **ES-AV12** - Ecosmart Alarm Visual Indicator.
- **ES-HUMIDISTAT2** - Ecosmart humidistat with set point adjustment and system status LED's.
- **ES-JB** - Ecosmart junction box.
- **ES-VF** - Ecosmart Volt Free Relay Box.

## 7.2 Unit serving kitchen and bathroom

Figure 7.

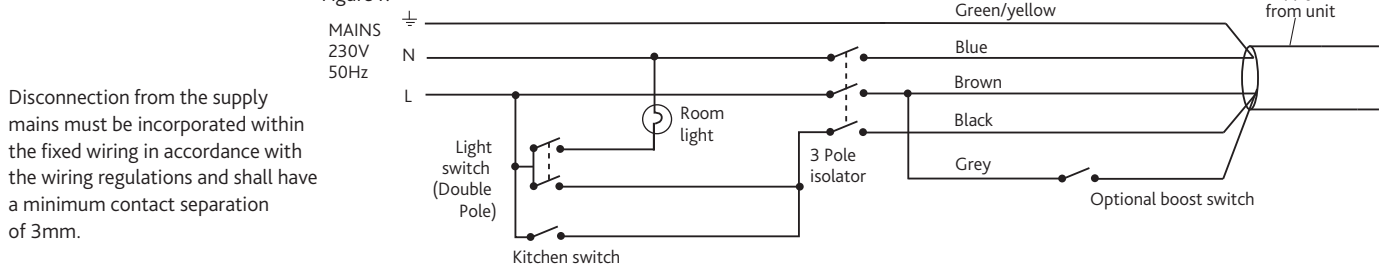

Disconnection from the supply mains must be incorporated within the fixed wiring in accordance with the wiring regulations and shall have a minimum contact separation of 3mm.

## 7.3 Unit serving kitchen and multiple bathrooms

Figure 8.

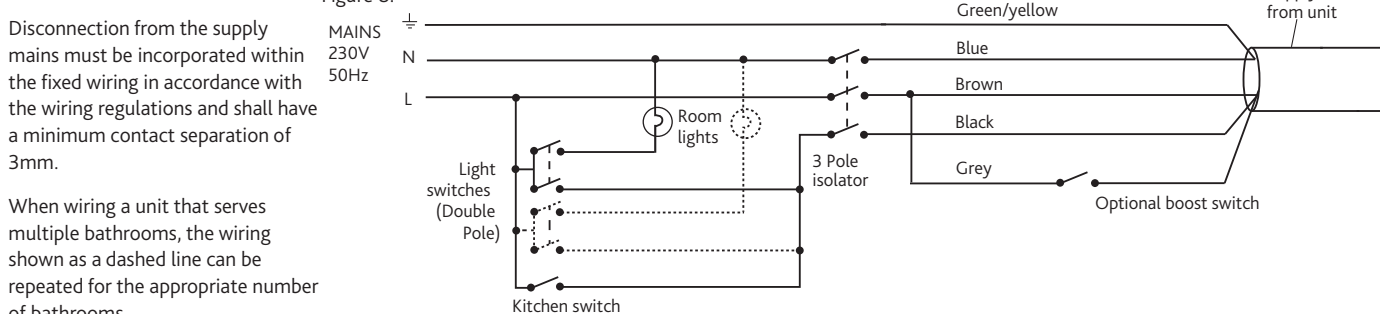

Disconnection from the supply mains must be incorporated within the fixed wiring in accordance with the wiring regulations and shall have a minimum contact separation of 3mm.

When wiring a unit that serves multiple bathrooms, the wiring shown as a dashed line can be repeated for the appropriate number of bathrooms.

Electrical details:-

Voltage: 240V 1ph 50Hz

Unit Code	Power Consumption	Running Current
UNI-X220	168 W	1.5 A
UNI-X360	168 W	1.5 A
UNI-X580	340 W	2.8 A

**NOTE: This unit must be earthed.**

The five core cable from the mains power supply should be connected to a fixed wiring installation, via a fused isolator, in accordance with current IEE wiring regulations.

Figure 9. PCB

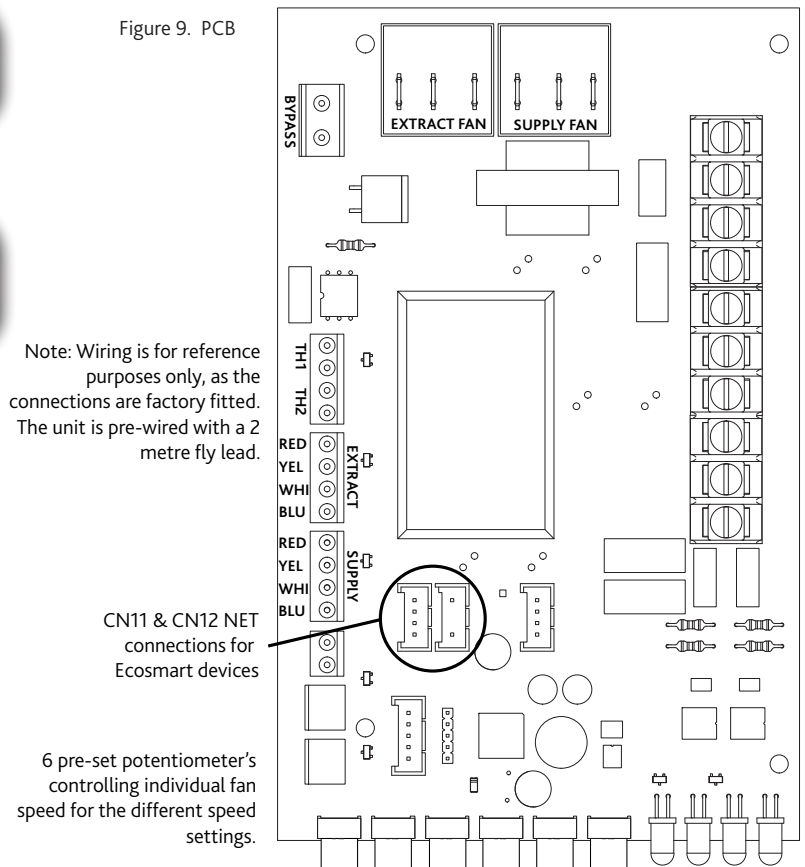

Note: Wiring is for reference purposes only, as the connections are factory fitted. The unit is pre-wired with a 2 metre fly lead.

CN11 & CN12 NET connections for Ecosmart devices

6 pre-set potentiometer's controlling individual fan speed for the different speed settings.

## 8.0 COMMISSIONING

The unit is supplied with independent fan speed control via the potentiometers (see Figure 6) for both normal and boost and maximum airflows.

Commissioning should be carried out in accordance with building regulations document "domestic ventilation compliance guide".

A calibrated moving vane anemometer and hood will be required for the commissioning, and adjustment valves should be locked in place to prevent further adjustment.

Once commissioned the unit should not be adjusted as it will have a detrimental effect on the indoor air quality and could result in condensation and mould growth. The label covering the control has an adhesive panel which should be removed post commissioning to prevent tampering.

## 9.0 STATUS INDICATION

The status of the unit is indicated by a series of LED's on the front cover. The variants are listed below.

Speed 1	●	○	○	○
Speed 2	●	○	☀	○
Speed 3	●	○	●	○
Supply Fan Fault	●	●	○	○
Extract Fan Fault	●	☀	○	○
Frost Protection	●	○	●	●
Filter Change	●	○	○	☀
HX Bypass (AB units only)	●	○	☀	☀

## 9.1 Frost Protection

In the event of the intake air temperature at the unit dropping below the predetermined set point (-5°C as standard) the supply fan will reduce to minimum speed, once the temperature rises above the set point the fan will return to its commissioned speed.

Please note this mode will only activate after ten days of continuous run time. If commissioning of the unit is outside of this time frame please notify the after sales department prior to site visit.

## 9.2 HX Bypass

The HX bypass damper shall open automatically under certain scenarios allowing the supply air to bypass the heat exchanger. These scenarios are described below.

- Outdoor temp > 10°C  
AND  
Indoor temp > Outdoor temp  
AND  
Inside temp > 25°C
- Outdoor temp > 10°C  
AND  
Outdoor temp > Indoor temp  
AND  
Outdoor temp < 25°C

**Note:** An amount of hysteresis is included in the strategy such that the "current" condition is maintained until 1°C past the control point.

## 10.0 MAINTENANCE

We recommend that the two G3 filters are inspected after 6 months and replaced every 12 months; this interval may need to be shortened, if the unit is operating under adverse environmental conditions.

The filters can be removed from the unit by removing the two filter covers on the bottom panel of the unit. Take hold of the two circular tabs either end of the filter covers and pull to remove (see Figure 7).

The filter can now be extracted by pulling the removal loop on the edge of the filter. Once the filters have been inspected return or replace them as necessary and refit the filter cover.

To fit the filter cover, insert both ends of the cover into the filter slot and press down on the centre (see Figure 8). Ensure that a full seal is made between the unit and the cover. Any incorrectly fitted covers will cause a performance drop of the unit.

Inspect the heat exchanger every 5 years. Generally check for damage and security of components.

Figure 10. Commissioning control.

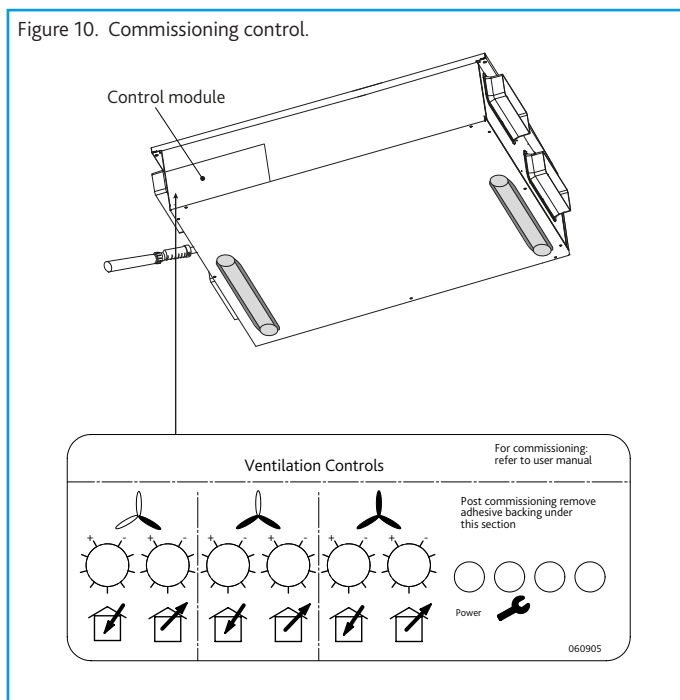

Figure 11. Filter replacement.

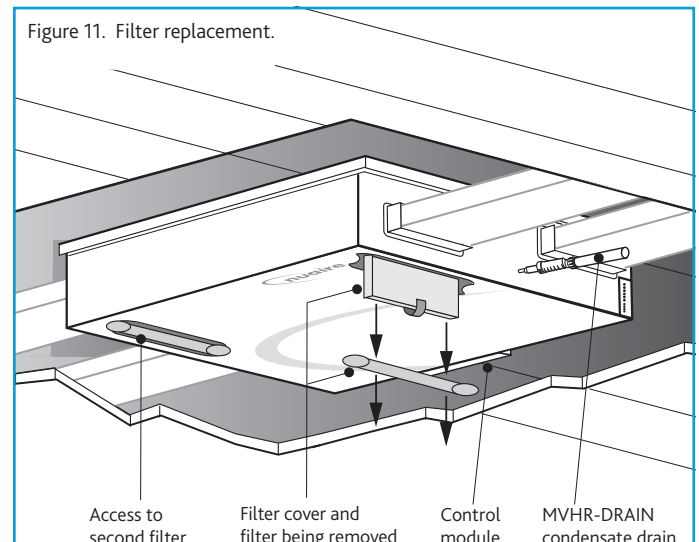
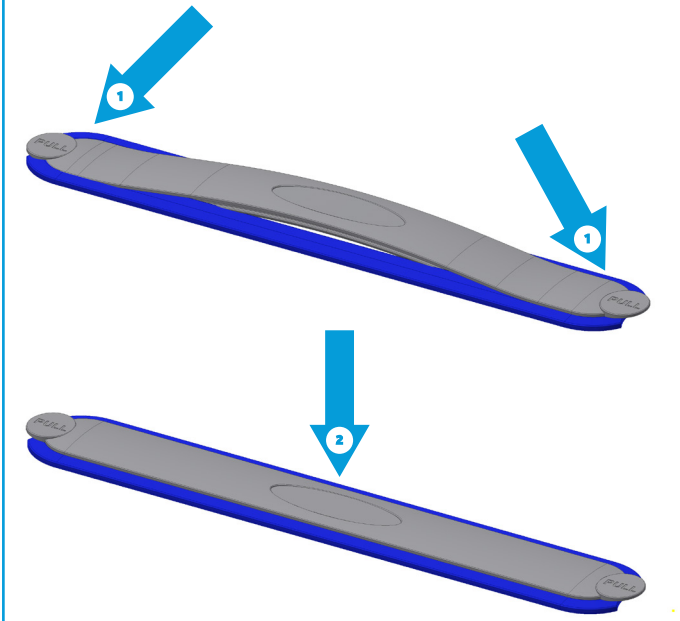



Figure 12. Fitting the filter cover.



### IMPORTANT

Isolation - Before commencing work make sure that the unit, switched live and Nuair control are electrically isolated from the mains supply and switched live supply.

## 12.0 WARRANTY

The 2 year warranty starts from the day of delivery and includes parts and labour for the first year and parts only for the remaining 1 year. This warranty is conditional on planned maintenance being undertaken.

This warranty is void if the equipment is modified without authorisation, is incorrectly applied, misused, disassembled, or not installed, commissioned and maintained in accordance with the details contained in this manual and general good practice.

The product warranty applies to the UK mainland and in accordance with Clause 14 of our Conditions of Sale. Customers purchasing from outside of the UK should contact Nuair International Sales office for further details.

## 13.0 AFTER SALES ENQUIRIES

For technical assistance or further product information, including spare parts and replacement components, please contact the After Sales Department.

Telephone 02920 858 400  
[aftersales@nuaire.co.uk](mailto:aftersales@nuaire.co.uk)

## 11.0 REPLACEMENT OF PARTS

Should any component need replacing Nuair keep extensive stocks for quick delivery. Ensure that the unit is electrically isolated, before carrying out any work.

Note: The supply cable must be replaced by an electrically competent person.

When ordering spare parts, please quote the serial number of the unit and the ARC number of the purchase if possible (**this information will be available on the fan label**).

**In the unlikely event of motor failure, the unit must be lowered from its installation position in order to facilitate a motor replacement. An access hatch of sufficient size for the unit to pass through is required. You must ensure that all associated electrical, condensate and ductwork connections can be disconnected.**

### 11.1 Motor Replacement

With the unit taken down from its installed position, the motors can be replaced by following the below procedure:

1. Unscrew all the black plastic Expanded Polystyrene (EPS) fixings in the top, sides and ends of the unit using a Torx Driver Bit, T25 x 70 mm (RS component no. 769-119).
2. Unscrew the three screws at the top of both end panels; this will release the top plate of the unit.
3. Remove the earth fixing that connects the top plate to the unit control panel.
4. Remove the top plate of the unit, lifting directly upwards using the safety edges along the side of the top plate.
5. Unscrew all bolts and screws from the newly exposed EPS foam lid and remove foam lid. This allows access to replace the unit motors.
6. Once motor replacement has been completed reassemble the unit in reverse operation to the process described above. Ensure all fixings are replaced and secure prior to testing the unit.