



Installation and Maintenance

SIL-WM2 (Silencer) FF-WM2 (Plenum Chamber) ACOUSTIC SOLUTION SYSTEM

For Wall/Cupboard Mounted MRXBOX95(AB)-WM2 MVHR Units

INDOOR USE ONLY

1.0 Introduction

Nuaire's First Fix and Acoustic Solution system is designed to not only significantly reduce noise but to improve the installation when wall or cupboard mounting the MRXBOX95(AB)-WM2 MVHR Units. Offering a complete MVHR acoustic and first fix solution to overcome both noise and ease the installation of heat recovery units.

Nuaire's system addresses both duct and breakout noise; provides an aesthetically pleasing cupboard installation for the home occupant and reduces installation errors and time.

Note: Information shown refers to complete system, not all parts will be relevant if part of system is fitted.

Fig 1: Units and components required to create the Acoustic Enclosure and Ducting for Wall Mounted MRXBOX95(AB)-WM2 MVHR Units.

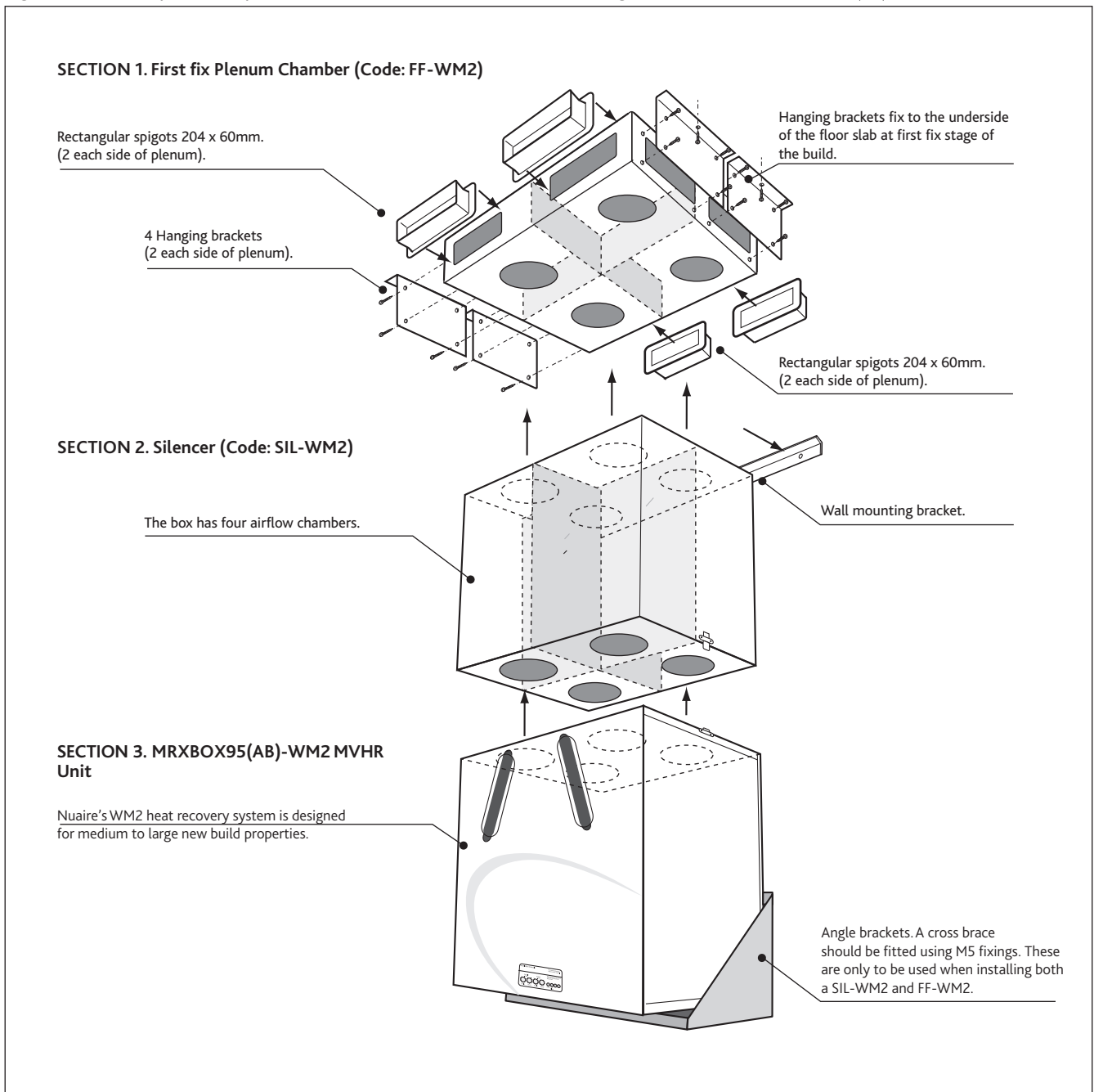

2.0 General Installation

Installation must be carried out by competent personnel in accordance with the appropriate authority and conforming to all statutory governing regulations.

No boarding should take place until after the full system installation has been completed.

Please note a clear working space is required around the MRXBOX95(AB)-WM2 installed unit to allow the cover to be removed and provide sufficient access for maintenance such as filter change. Please allow a minimum of 350mm in front of the unit.

The fan must be installed indoors, on a suitable wall away from direct sources of frost, heat, water spray or moisture generation.

For a vibration-free result the unit must be mounted to a solid wall.

(For further installation information for the MRXBOX95(AB)-WM2 unit please refer to installation document supplied with the MVHR unit).

2.1 Installation (Sealing)

FF-WM2 (Plenum Chamber)

Fit rectangular spigots to required positions, the remaining cut outs should be covered by the 4 hanging brackets supplied. All components should be fitted with self-tapping screws provided and sealed with silicone.

When fitting the spigots to the foam lined chamber of the plenum, the foam should be cut away in the openings where the spigots are to be fitted.

If SIL-WM2 is not being used 125mm diameter spigots should be fitted with self-tapping screws provided and sealed with silicone.

SIL-WM2

Remove 4 x 125mm spigots from MRXBOX95(AB)-WM2 and fit a length self-adhesive seal around the perimeter of each cut-out covering the screw heads, see fig. 2.

If FF-WM2 is not being used, the spigots removed from the MRXBOX95(AB)-WM2 can be re-fitted to the top panel of SIL-WM2 using the same fixings and sealed with silicone.

Otherwise fit the remaining length of self-adhesive seal to the top surface of the SIL-WM2 to form a sealed perimeter around each circular cut out, see fig. 3.

Ensure all joints are mated neatly to prevent leakage.

Fig 2:MRXBOX95(AB)-WM2 viewed from above.

Remove 4 x 125mm spigots from MRXBOX95(AB)-WM2 and fit a length of self-adhesive seal around the perimeter of each covering the screw heads.

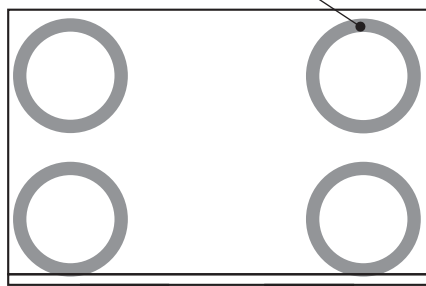
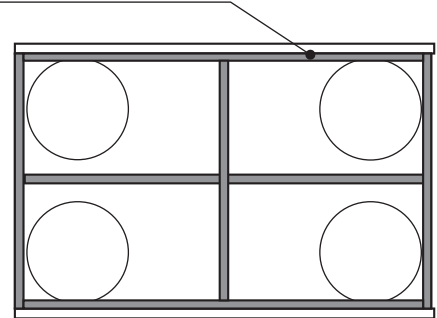

Fig 3: SIL-WM2 viewed from above.

Self-adhesive seal around top surfaces of the SIL-WM2 airflow chambers to form a sealed perimeter.



2.2 Installation (First Fix)

FF-WM2 (Plenum Chamber)

The first fix plenum chamber should be fixed (fixings supplied by others) with the off centre cylindrical cutouts nearest to the wall the MRXBOX95(AB)-WM2 is to be installed on. A 30mm clearance between the wall and the rear face of the plenum chamber is required.

See fig. 1 and 10.

The ceiling of the property will require an appropriate size cut out to allow the connection to be made when the secondary items are to be fitted.

Fig 4: FF-WM2.

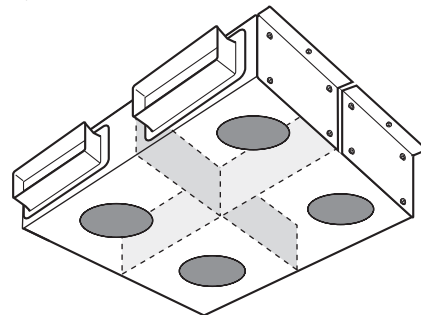

2.3 Installation

SIL-WM2 (Silencer)

The unit is designed for mounting on a solid wall, a gypsum block or stud/plasterboard wall will not suffice. If fixing to a stud wall a piece of MDF at least 25mm thick should be solidly fixed behind the board, the MDF panel should ideally run from floor to ceiling but must be a minimum of 2m. The MDF panel should also extend width wise over a minimum of three studs with centres no more than 400mm, additional vertical supports may be required.

For more detailed information on how to mount the unit and structural requirements please refer to the I&M document supplied with the MVHR unit.

Please note that a clear working space is required around the installed MRXBOX95(AB)-WM2 unit to allow the cover to be removed and provide sufficient access for maintenance such as a filter change. Please allow a minimum of 430mm in front of the unit. (continued overleaf).

2.3 Installation (cont.)

SIL-WM2 (Silencer)

The below information regarding the angle brackets is only relevant when the installation includes both a SIL-WM2 and FF-WM2, if this is not the case MRXBOX95(AB)-WM2 should be fitted using the standard installation instructions supplied with that product. If only fitting an SIL-WM2 this should then be sat on top of the MVHR unit and clamped in place as detailed later in this section.

The wall mounting brackets and angle brackets should now be fitted (fixings supplied by others) according to the installed position of the plenum and the measurements shown in fig 9.

SIL-WM2 to be hung on the wall using mounting bracket supplied loose in the MRXBOX95(AB)-WM2 packaging, see below.

The MRXBOX95(AB)-WM2 unit can then be sat on the angle brackets, and the cross brace should be fitted using the M5 fixings provided once the MRXBOX95(AB)-WM2 is in position.

Raise the units using the adjustment feet provided until the SIL-WM2 is lifted off its wall mounting bracket, ensuring the two sections are correctly aligned and fasten the toggle clamps on the sides of the units. The safety pins supplied should be fitted to secure the clamps in place. (see fig. 7). Continue to raise the units using the adjustment feet again checking for good alignment to form a seal against the FF-WM2 and ensure installation is level.

When positioning is complete the adjustment feet should be secured in position using the four locking nuts. (see fig. 8).

Please note the above method is the preferred installation arrangement, a minimum gap of 75mm either side of the unit is advised to allow access to the toggle clamps.

If space constraints do not allow this, the toggle clamps can be replaced with the metal fixing plates provided (see fig. 9). The MRXBOX95(AB)-WM2 + SIL-WM2 will need to be secured together and lifted as one assembly using suitable lifting equipment.

Fig 5: Wall mounting bracket.

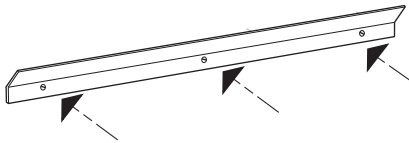

Fig 6: Mounting the unit on the wall mounting bracket.

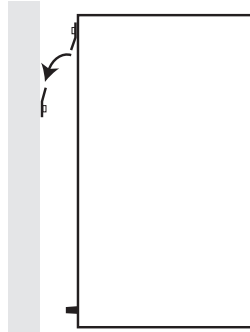

Fig 7: Toggle clamp.

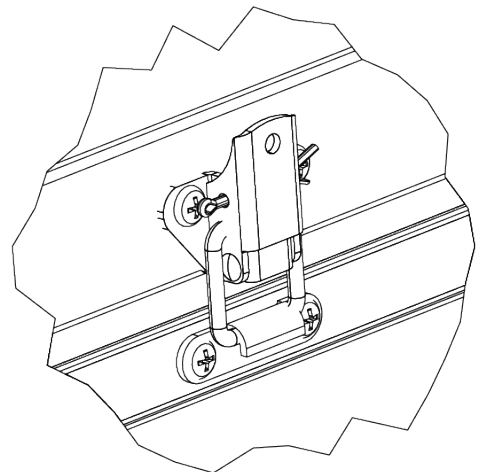

Fig 8: View of locking nut.

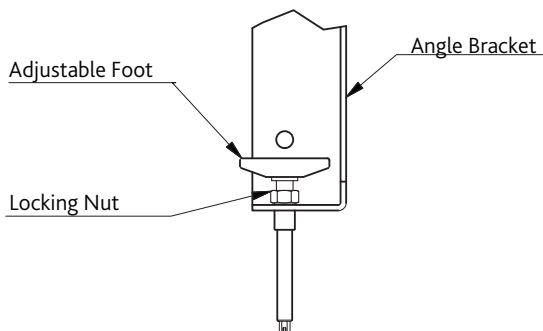
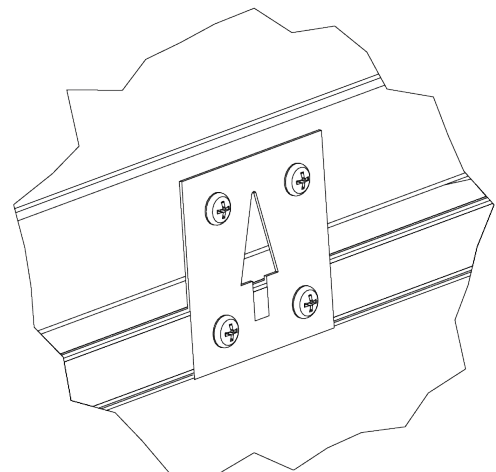

Fig 9: Fixing plate.



3.0 Dimensions

Fig 10 : SIL-WM2.

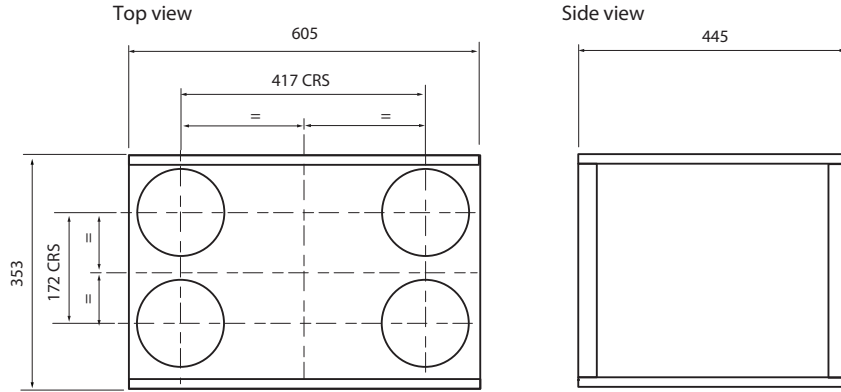

Fig 11: FF-WM2

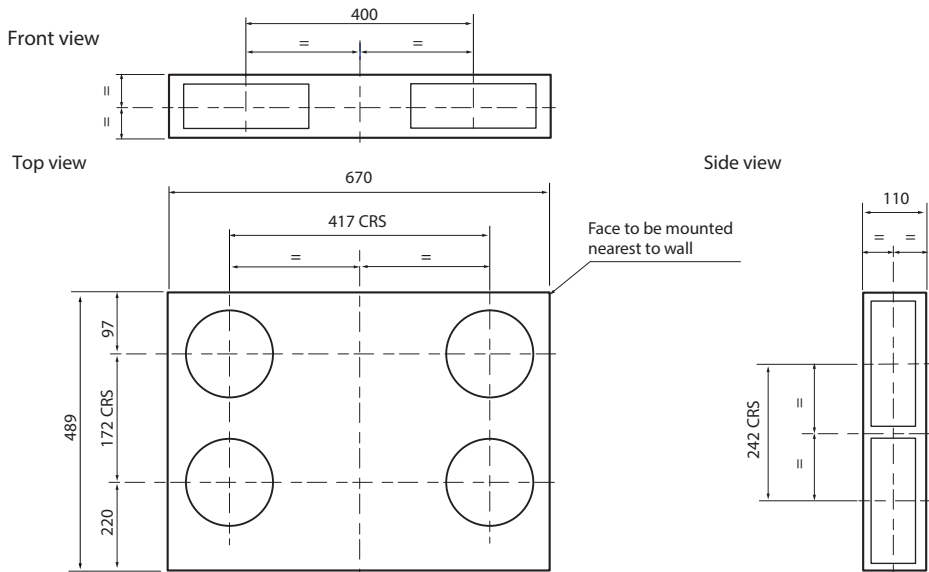
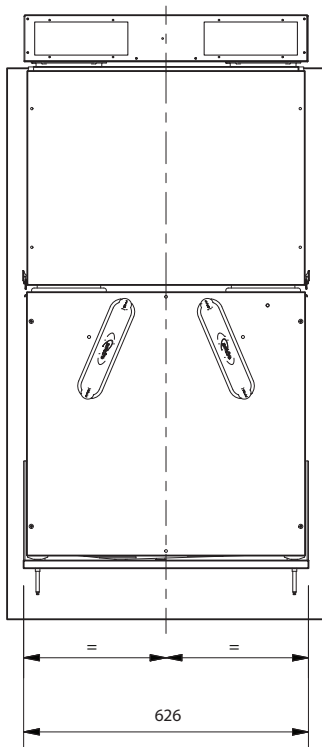

Fig 12: Initial positioning before clamping and sealing.

Front view



Side view

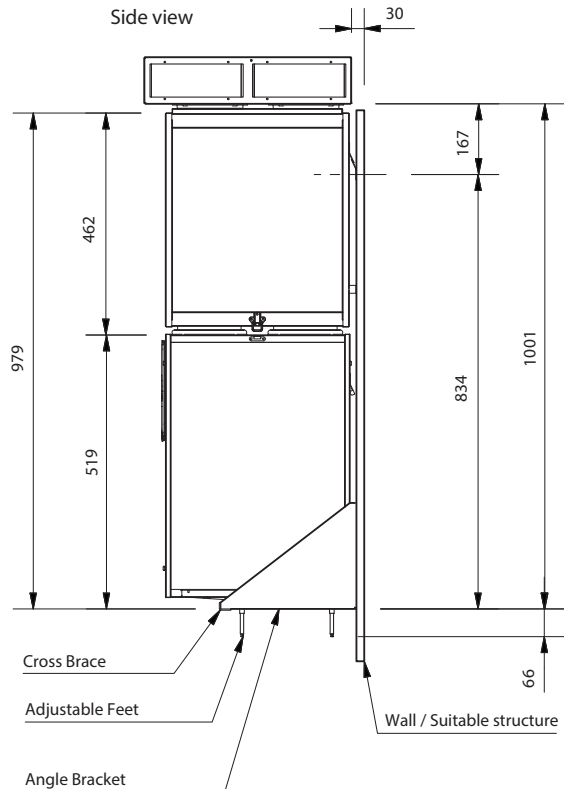
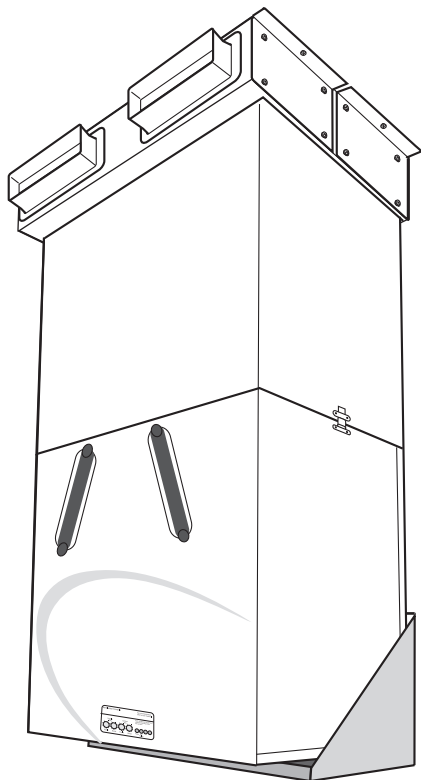

Fig 13: View of completed system.



4.0 Replacement of Parts

Should any component need replacing Nuair keep extensive stocks for quick delivery. Ensure that the unit is electrically isolated, before carrying out any work.

When ordering spare parts, please quote the serial number of the unit and the ARC number of the purchase if possible.

(This information will be available on the fan label).

5.0 Warranty

The 5 year warranty starts from the day of delivery and includes parts and labour for the first year and parts only for the remaining 4 years.

This warranty is void if the equipment is modified without authorisation, is incorrectly applied, misused, disassembled, or not installed, commissioned and maintained in accordance with the details contained in this manual and general good practice.

The product warranty applies to the UK mainland and in accordance with Clause 14 of our Conditions of Sale. Customers purchasing from outside of the UK should contact Nuair International Sales office for further details.

6.0 After Sales Enquiries

For technical assistance or further product information, including spare parts and replacement components, please contact the After Sales Department.

Telephone 02920 858 400

Technical or commercial considerations may, from time to time, make it necessary to alter the design, performance and dimensions of equipment and the right is reserved to make such changes without prior notice.