



# Natural Ventilation

ε-stack A-Series Ventilation System  
for Buildings with Atria

## Installation and Maintenance

### Important Notes to Designers and Installers

Atria are often designed into buildings to provide a light and airy environment which is adaptable for the needs of the occupants. By providing a flow path through the building, they can also aid the adoption of a natural ventilation strategy for the surrounding rooms.

Nuaire has developed an innovative low energy approach to the ventilation of buildings where rooms are connected to a central atrium. The system can be deployed in buildings with one storey as well multi-storey buildings. In winter, high level vents or windows in the atrium are used to bring fresh cold air into the building as well to exhaust the hot polluted air. The air mixes naturally in the atrium owing to the convective flow patterns which develop in the space. The Nuaire A-series units are then used to exchange the atrium air with the occupied rooms adjacent to the atrium.

In summer the building is ventilated using upflow displacement ventilation. Air enters through exterior windows in each room before flowing into the atrium through specially designed Nuaire ε-stack A-Series transfer units. The air rises within the atrium and exits through the high level windows or vents at the top of the space. The large difference in height between the low level entry of fresh air and the exit of warm air through the atrium creates a large buoyancy effect which draws air through the building.

#### Controlled ventilation

The ventilation system is fully controlled from a central control panel with dedicated temperature and CO<sub>2</sub> sensors for each space. This allows the system to optimise the ventilation strategy for comfort and energy use. The panel also controls the high level openings in the atrium and provides a signal to the LED interface panel in each space to indicate when the windows should be opened.

Figure 1. ε-stack A-Series isometric.

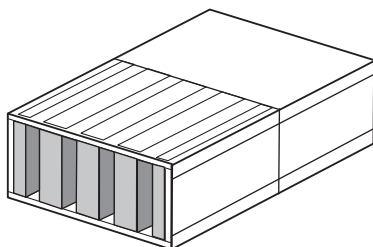

#### Construction

A-Series Ventilation units are constructed with Galvanised steel or Zintec. The units can be supplied in Standard galvanised finish or Zintec powder coated to RAL9010 as standard.

The A-Series units have been acoustically tested in accordance with BS EN 20140-10:1992 and ISO 140-10:1991 and are shown to meet the requirements of BB93 – Acoustic Design of Schools.

### 1.0 Handling

Each ε-stack A-Series unit is delivered to site suitable for forklift handling. (Unit weight approx 220kg).

Figure 2. Lifting examples.

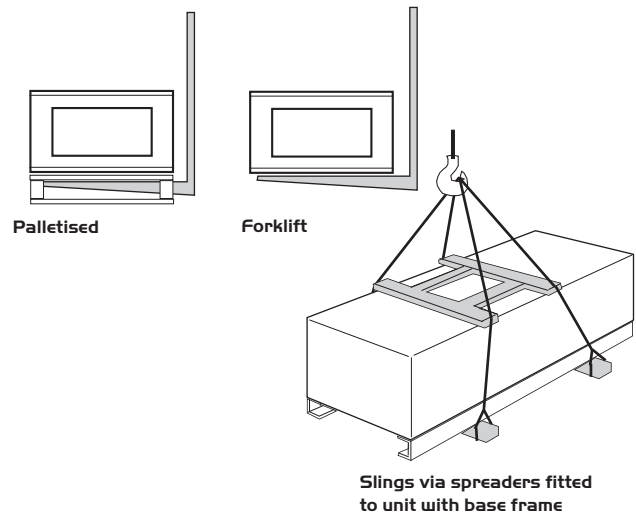

### 2.0 Installation

Installation must be carried out by competent personnel in accordance with the appropriate authority and conforming to all statutory and governing regulations e.g. I.E.E., CIBSE, COHSE etc.

#### 2.1 Opening requirements

1) High-level windows in the atrium are to have a minimum total effective opening area as specified for the project. Ventilation area at high level in the atrium is provided by actuated windows and/or dampered vents behind weather louvres. These vents can be controlled from the ε-stack control panel using Volt-free Contacts (VFC) or O-IOVDC control signals.

Power to window actuators should be supplied by others.

2) Windows or dampered vents (behind weather louvres) at low-level in the rooms to the side of the atrium should have a minimum effective opening area as specified for the project. If actuated windows or dampered vents are used, these can be controlled by the ε-stack system.

If manual windows are used, Nuaire will supply a red/blue open/close windows LED plate to instruct the occupants of the room on when to open their windows to get the most benefit from the system.

## 2.2 Installation of the A-Series units

Whilst e-stack provide recommendations for the installation of supports for the units, the sizing and detailed design of the load-bearing supports must be specified and signed off by the structural engineers for the project. Two fixing methods are suggested:

1. Vertical support studding attaches to either side of a cradle which supports the e-stack unit. The cradle can be formed from a unistrut channel.

Figure 3. Option 1. Unistrut channel cradle.

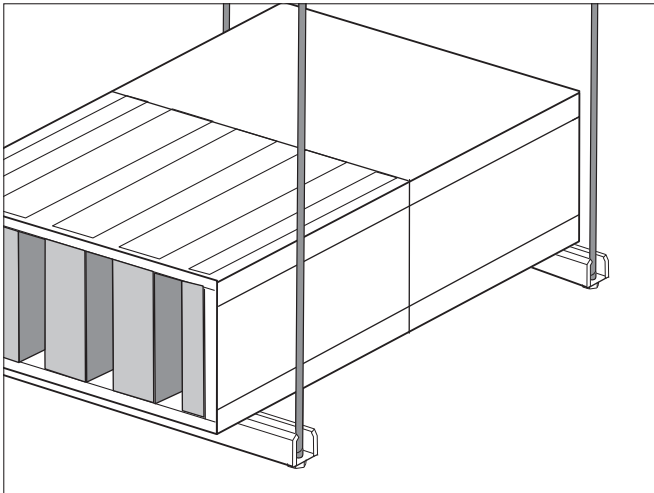

2. e-stack mounting brackets supplied (at additional cost) and used in conjunction with drop-rods to support the units. (see figures 4 and 5).

Figure 4. Option 2, showing drop rods attached to unit.

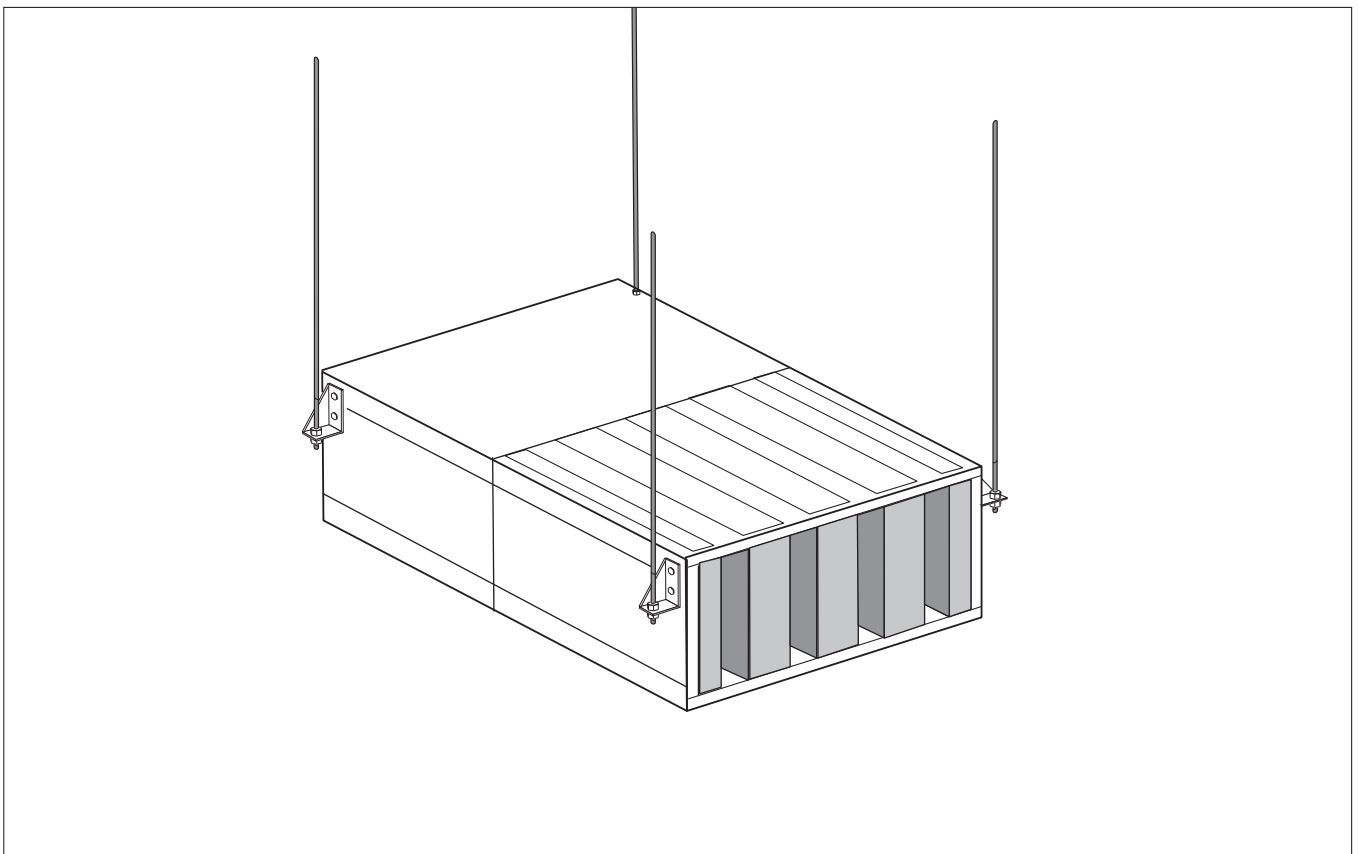

Ventilation unit hangs from 4no. pieces of M12 studding of maximum length 1200mm.

Drop-rods attached to A-Series unit using welded brackets (supplied at additional cost).

The bracket length is 65mm to the centre of the fixing hole.

The unit is lifted into place and four M12 Studding (drop-rods) are brought through the holes on the end of the welded brackets, positioned and secured in place using a pair of M12 full nuts per bracket. (see figure 4).

Figure 5. Option 2, close up of bracket.

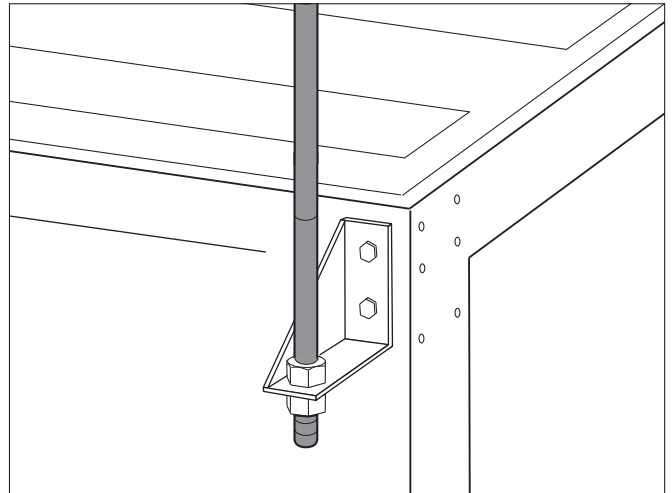

**Note: A room set comprises two A-Series units. These may be positioned in a bulkhead, suspended ceiling or left visible within the space.**

### 2.3 Grille Requirements

e-stack units contain fast moving fans and must have grilles on all open faces when in operation.

- Where the base of the unit is installed less than 2.7m vertical distance from the floor, specific grilles provided by Nuair must be used.
- Where the unit is installed more than 2.7m vertical distance from the floor, grilles can optionally be provided by Nuair.

### 2.4 Installation Guidelines

Figure 6. Typical installation diagram.

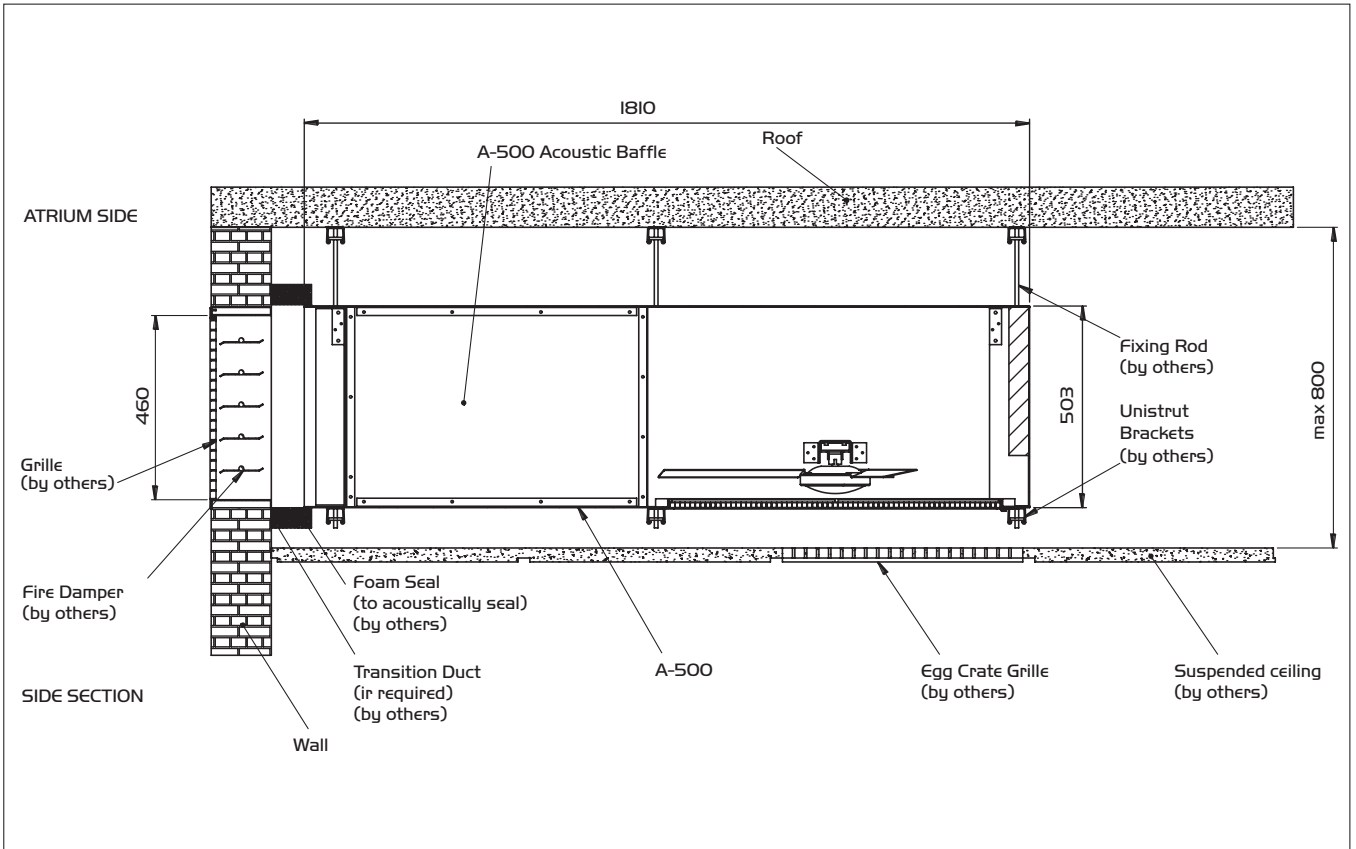
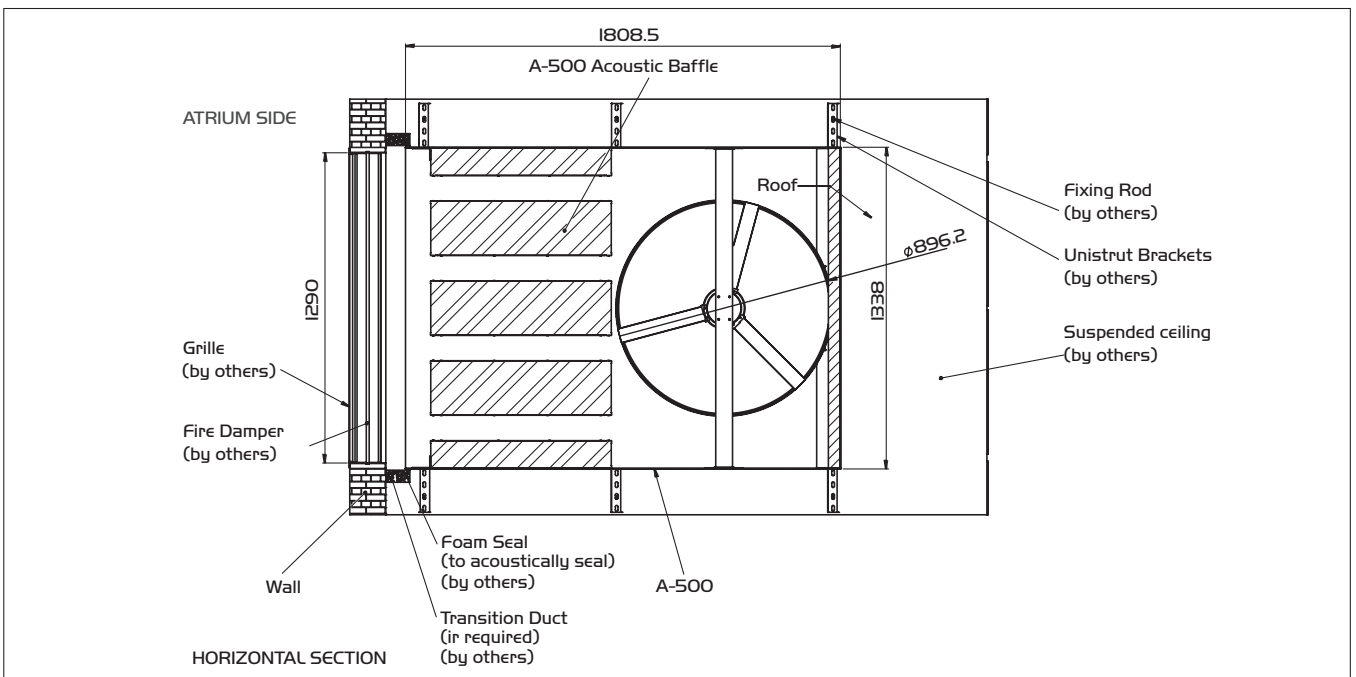

Figure 7. Typical installation diagram.



## 2.5 Electrical Installation

Installation must be carried out by a qualified electrician in accordance with the appropriate authority and conforming to all statutory and governing regulations.

## 2.6 Central Control Panel

The control panel serving 10 - 20 rooms will typically be: 1500mm wide x 1500mm high x 500mm deep.

Panels for smaller or larger numbers of rooms will vary in size and specification. A touch screen interface is also available at additional cost which allows testing and monitoring of current operation.

## 2.7 Sensors

### Exterior Temperature Sensor

This sensor (supplied) should be located on the exterior facade, preferably in a permanently shaded position e.g. below roof eaves. If this is not possible, it should be positioned in a location receiving minimal direct sunlight, and not on a south facing facade where the largest direct solar radiation is observed.

### Room Temperature and CO<sub>2</sub> Sensors (combined)

One (supplied) for each room containing e-stack transfer units. This should be mounted at eye-level and away from windows or doors in frequent use, as these may locally reduce CO<sub>2</sub> concentrations.

## 2.8 Room Indicator LED Panel

This indicates to the user when to open or close the windows in installations with manually opening facade windows. A blue LED illuminates to show when the user should shut the windows and a red LED when the user should open the windows. This display should be located where it is most visible to the occupants of the low-level windows.

The room indicator panel requires a 50mm deep switch plate box.

### Room Indicator Panel Dimensions (mm)

146mm wide x 85mm high

### IMPORTANT

For good EMC engineering practice, any sensor cables or switched live cables should not be placed within 50mm of other cables or on the same metal cable tray as other cables.

Figure 8. Wiring details.

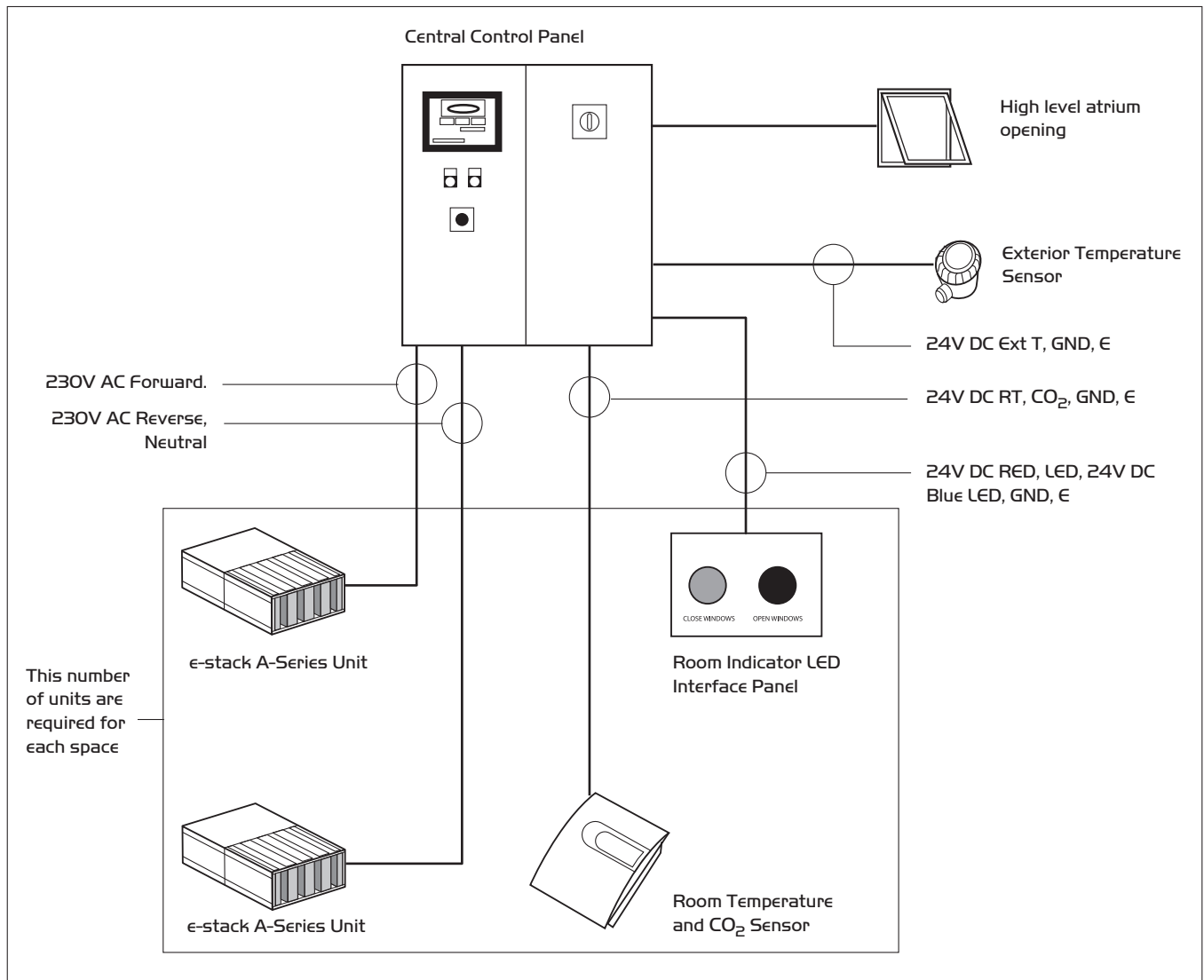

2.9 Wiring Diagrams

Figure 9. Wiring: Multiple Exterior Temperature Sensors.

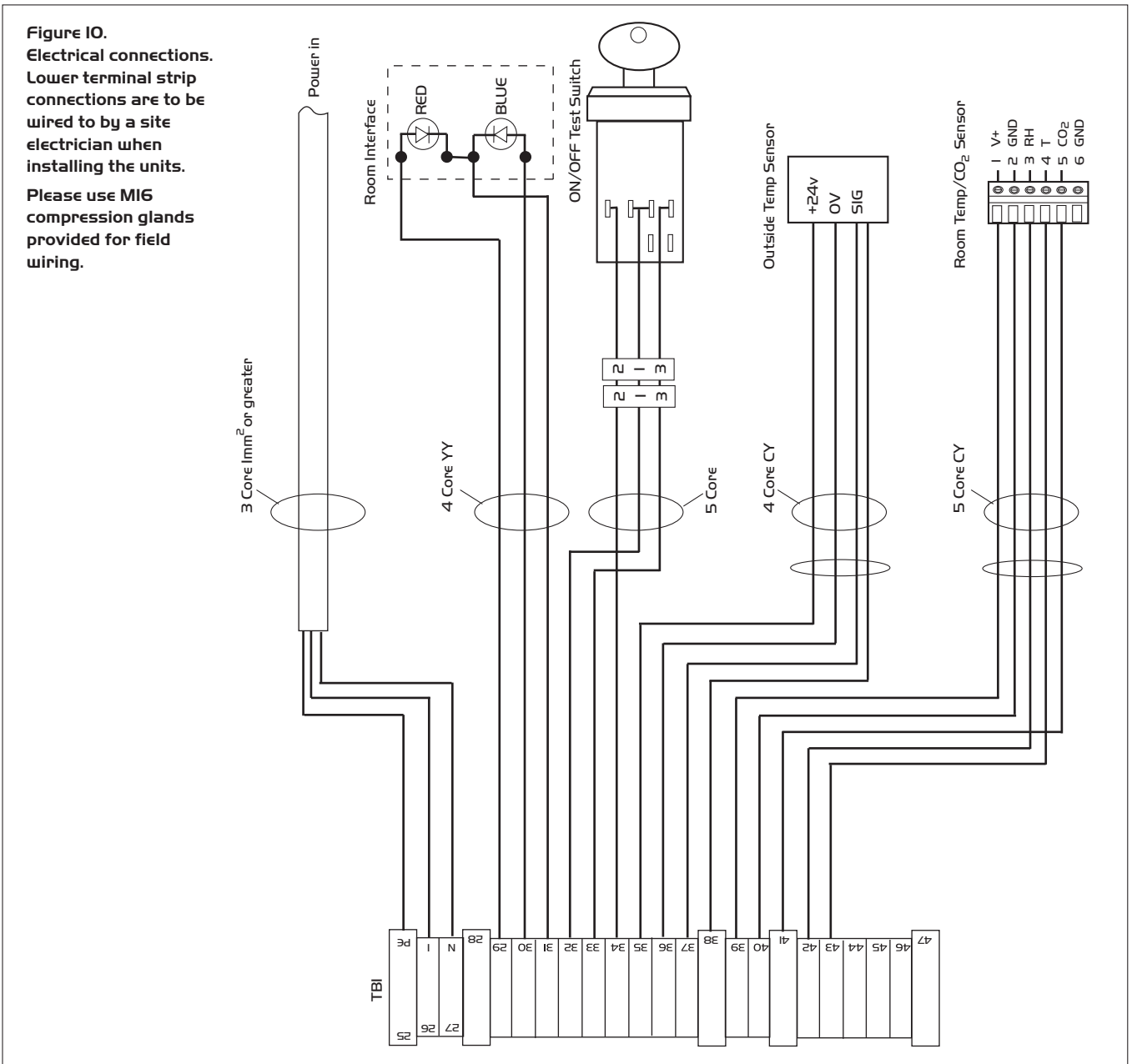
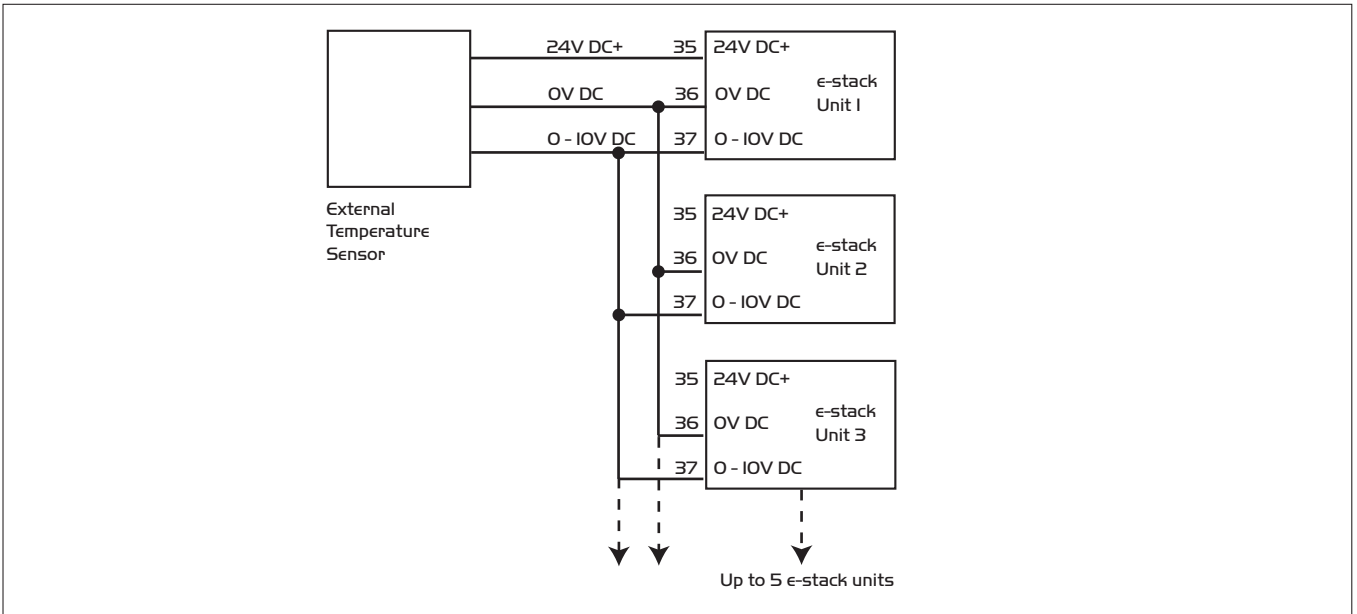

### 3.0 Dimensions e-stack A-Series (mm)

Figure II.

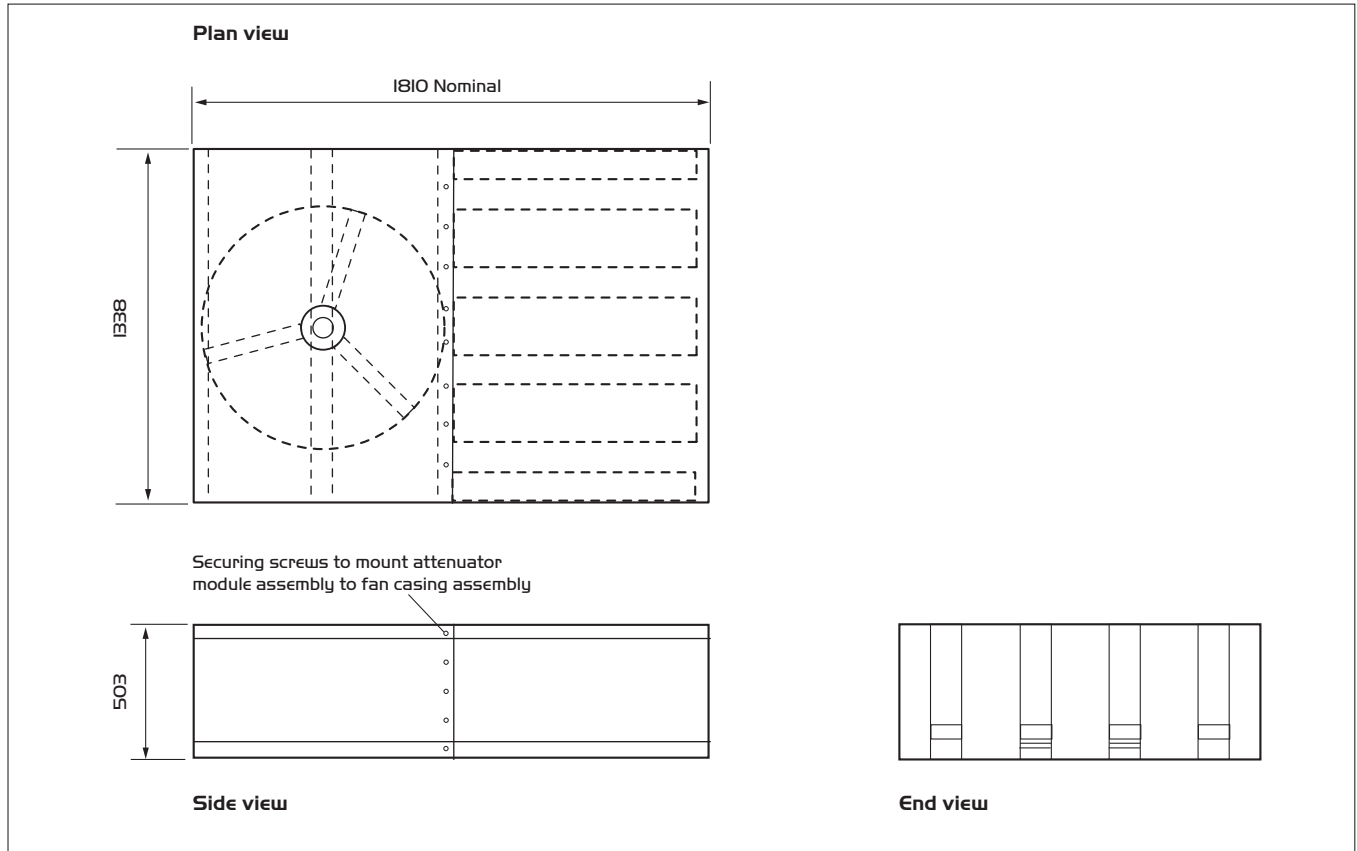

### 4.0 Maintenance

A 6 monthly inspection is required and any debris removed.

### 5.0 Warranty

The 3 year warranty starts from the day of delivery and includes parts and labour for the first year. The remaining 2 years covers parts only. This warranty is conditional on planned maintenance being undertaken.

### 6.0 Service Enquiries

Nuaire can assist you in all aspects of service. Our service department will be happy to provide any assistance required initially by telephone and if necessary arrange for an engineer to call.

**Telephone 029 2085 8400**

## DECLARATION OF INCORPORATION AND INFORMATION FOR SAFE INSTALLATION, OPERATION AND MAINTENANCE

We declare that the machinery named below is intended to be assembled with other components to constitute a system of machinery. All parts except for moving parts requiring the correct installation of safety guards comply with the essential requirements of the Machinery Directive. The machinery shall not be put into service until the system has been declared to be in conformity with the provisions of the EC Machinery Directive.

Designation of machinery: e-stack A-Series  
 Machinery Types: Natural Ventilation System  
 Relevant EC Council Directives: 2006/42/EC (Machinery Directive)  
 Applied Harmonised Standards: BS EN ISO 12100-1, BS EN ISO 12100-2, EN60204-1, BS EN ISO 9001, BS EN ISO 13857  
 Applied National Standards: BS848 Parts 1, 2.2 and 5

### Signature of manufacture representatives:

Name:	Position:	Date:
1) C. Biggs	Technical Director	29.12.10
2) A. Jones	Manufacturing Director	29.12.10

Note: All standards used were current and valid at the date of signature.

## CE DECLARATION OF CONFORMITY

We declare that the machine named below conforms to the requirements of EC Council Directives relating to Electromagnetic Compatibility and Safety of Electrical Equipment.

Designation of machinery: e-stack A-Series  
 I & M Serial No.: 671532  
 Machinery Types: Natural Ventilation System  
 Relevant EC Council Directives: 2004/108/EC (EMC), 2006/95/EC (Low Voltage Directive)  
 Applied Harmonised Standards: EN55014-1, EN55014-2, EN61000-3-2, EN61000-3-3, EN60335-2-80  
 Basis of Self Attestation: Quality Assurance to BS EN ISO 9001 BSI Registered Firm Certificate No. FM 149

### Signature of manufacture representatives:

Name:	Position:	Date:
1) C. Biggs	Technical Director	29.12.10
2) A. Jones	Manufacturing Director	29.12.10

Nuaire Ltd,  
 Western Industrial Estate,  
 Caerphilly CF83 1NA.

Note: All standards used were current and valid at the date of signature.

## INFORMATION FOR SAFE INSTALLATION, OPERATION AND MAINTENANCE OF NUAIRE VENTILATION EQUIPMENT

To comply with EC Council Directives 2006/42/EC Machinery Directive and 2004/108/EC (EMC).

To be read in conjunction with the relevant Product Documentation (see 2.1)

### 1.0 GENERAL

1.1 The equipment referred to in this Declaration of Incorporation is supplied by Nuaire to be assembled into a ventilation system which may or may not include additional components.  
 The entire system must be considered for safety purposes and it is the responsibility of the installer to ensure that all of the equipment is installed in compliance with the manufacturers recommendations and with due regard to current legislation and codes of practice.

### 2.0 INFORMATION SUPPLIED WITH THE EQUIPMENT

2.1 Each item of equipment is supplied with a set of documentation which provides the information required for the safe installation and maintenance of the equipment. This may be in the form of a Data sheet and/or Installation and Maintenance instruction.  
 2.2 Each unit has a rating plate attached to its outer casing. The rating plate provides essential data relating to the equipment such as serial number, unit code and electrical data. Any further data that may be required will be found in the documentation. If any item is unclear or more information is required, contact Nuaire.  
 2.3 Where warning labels or notices are attached to the unit the instructions given must be adhered to.

### 3.0 TRANSPORTATION, HANDLING AND STORAGE

3.1 Care must be taken at all times to prevent damage to the equipment. Note that shock to the unit may result in the balance of the impeller being affected.  
 3.2 When handling the equipment, care should be taken with corners and edges and that the weight distribution within the unit is considered. Lifting gear such as slings or ropes must be arranged so as not to bear on the casing.  
 3.3 Equipment stored on site prior to installation should be protected from the weather and steps taken to prevent ingress of contaminants.

### 4.0 OPERATIONAL LIMITS

4.1 It is important that the specified operational limits for the equipment are adhered to e.g. operational air temperature, air borne contaminants and unit orientation.  
 4.2 Where installation accessories are supplied with the specified equipment eg. wall mounting brackets. They are to be used to support the equipment only. Other system components must have separate provision for support.  
 4.3 Flanges and connection spigots are provided for the purpose of joining to duct work systems. They must not be used to support the ductwork.  
 4.4 In the event of RF interference the fan may change speed. This is normal and will have no adverse effect on the fan. The speed will return to normal once the interference has subsided.

### 5.0 INSTALLATION REQUIREMENTS

In addition to the particular requirements given for the individual product, the following general requirements should be noted.

5.1 Where access to any part of equipment which moves, or can become electrically live are not prevented by the equipment panels or by fixed installation detail (eg ducting), then guarding to the appropriate standard must be fitted.  
 5.2 The electrical installation of the equipment must comply with the requirements of the relevant local electrical safety regulations.  
 5.3 For EMC all control and sensor cables should not be placed within 50mm or on the same metal cable tray as 230V switched live, lighting or power cables and any cables not intended for use with this product.

### 6.0 COMMISSIONING REQUIREMENTS

6.1 General pre-commissioning checks relevant to safe operation consist of the following:  
 Ensure that no foreign bodies are present within the fan or casing.  
 Check electrical safety. e.g. Insulation and earthing.  
 Check guarding of system.  
 Check operation of Isolators/Controls.  
 Check fastenings for security.  
 6.2 Other commissioning requirements are given in the relevant product documentation.

### 7.0 OPERATIONAL REQUIREMENTS

7.1 Equipment access panels must be in place at all times during operation of the unit, and must be secured with the original fastenings.  
 7.2 If failure of the equipment occurs or is suspected then it should be taken out of service until a competent person can effect repair or examination. (Note that certain ranges of equipment are designed to detect and compensate for fan failure).

### 8.0 MAINTENANCE REQUIREMENTS

8.1 Specific maintenance requirements are given in the relevant product documentation.  
 8.2 It is important that the correct tools are used for the various tasks required.  
 8.3 If the access panels are to be removed for any reason the electrical supply to the unit must be isolated.  
 8.4 A minimum period of two minutes should be allowed after electrical disconnection before access panels are removed. This will allow the impeller to come to rest.  
**NB: Care should still be taken however since airflow generated at some other point in the system can cause the impeller to "windmill" even when power is not present.**  
 8.5 Care should be taken when removing and storing access panels in windy conditions.



Western Industrial Estate  
Caerphilly United Kingdom  
CF83 1NA  
T: 029 2085 8200  
F: 029 2085 8300  
E: [ahu@nuaire.co.uk](mailto:ahu@nuaire.co.uk)  
W: [www.nuaire.co.uk](http://www.nuaire.co.uk)

Technical or commercial considerations may, from time to time, make it necessary to alter the design, performance and dimensions of equipment and the right is reserved to make such changes without prior notice.