

XBOXER 55

Supply & Extract Ventilation Unit with Heat Recovery

Installation, Operating and Maintenance Instructions

XBOXER 55

The information contained in this document provides details of installation, operation and maintenance for installers and users of the XBOXER 55 Supply and Extract Ventilation Unit with Heat Recovery.

These air handling units comprise a combination of three modular sections assembled to suit the application requirements as specified by the purchaser, they comprise:

1. XBOXER 55 Atmosphere Side Silencer and Mixing Box
2. XBOXER 55 Central Fan Unit
3. XBOXER 55 Room Side Silencer

The XBOXER 55 Central Fan Unit houses two fan units with associated air filters, a plate heat recovery section, an optional supplementary heater (LPHW or Electric).

General information regarding performance and specifications for the equipment may be obtained from our Technical Literature, and / or project specific documentation.

Figure 1: Dimensions of modular sections viewed from above and access panels for the sections.

Access for maintenance and inspection of the XBOXER 55 units is generally from the sides. (for details of individual component access, see figure 1).

Code description:

XBOXER 55 Central Ventilation Unit

XB 55 - L - €

1	2	3

1. XBOXER 55 Range
2. L = Left, R = Right

3. € = Electric heater
N = No heater
U, L2, L3, L4 = LPHW heater

Code description:

Silencer & Mixing Box

XB 55 - SIL - AT - M - L - 240

1	2	3	4	5	6

1. XBOXER 55 Range
2. SIL = Silencer
3. AT = Atmosphere side or RM = Roomside
4. M = Mixing box (control by others)

5. L = Left, R = Right
6. 240 = 240V actuator,
24 = 24V DC actuator,
24/10 = 24V actuator with 0-10V modulation control

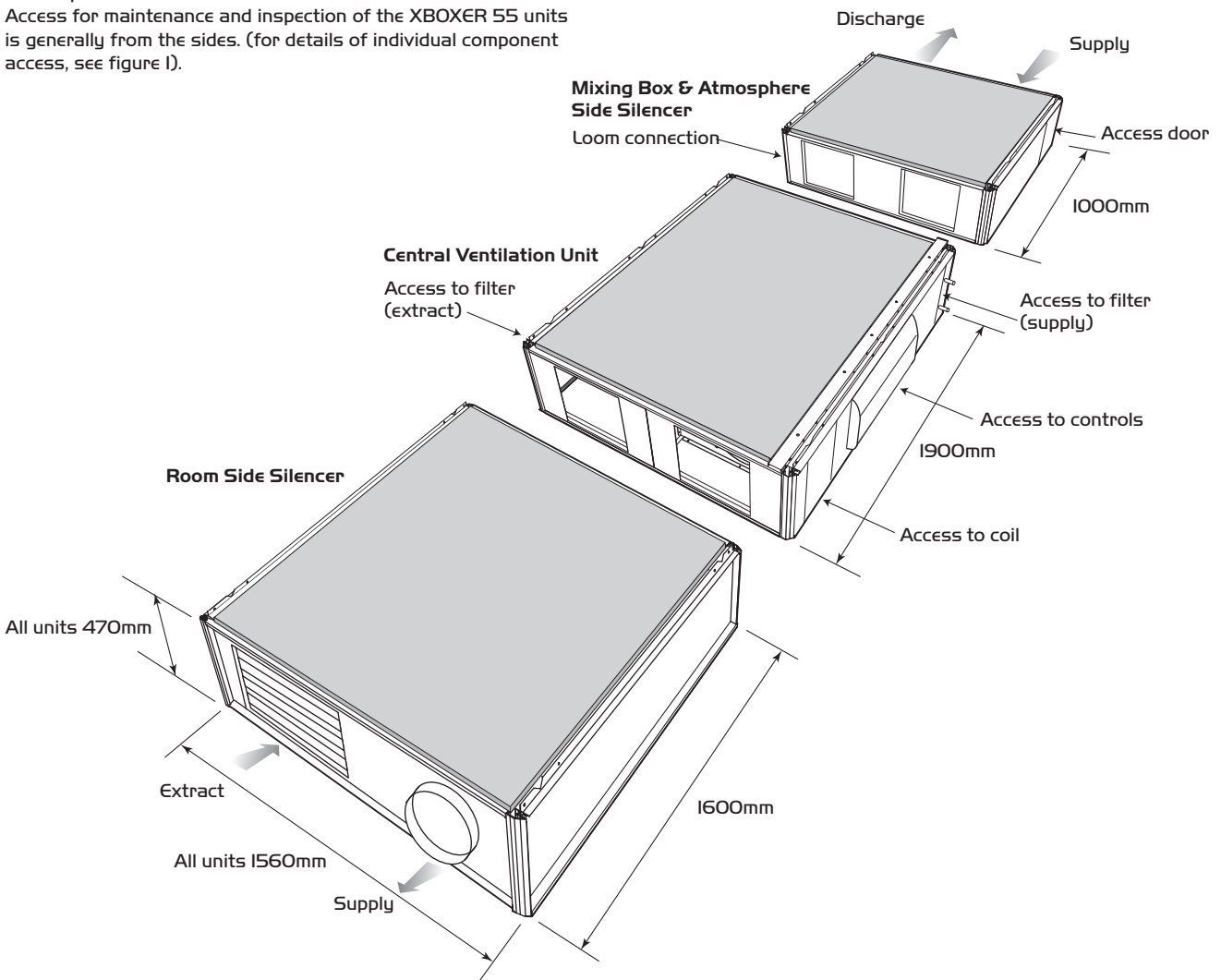

IMPORTANT

- Safety first! –before commencing any work ensure:
- That all appropriate risk assessments have been carried out, and the required safety measures have been taken
 - That you understand the work required
 - That you are trained and competent to carry it out

I.0 Delivery of Equipment

I.1 Receipt of equipment

All equipment is inspected prior to despatch and leaves the factory in good condition. Upon receipt of the equipment an inspection should be made and any damage indicated on the delivery note.

Particulars of damage and/or incomplete delivery should be endorsed by the driver delivering the goods before offloading by the purchaser.

No responsibility will be accepted for damage sustained during the offloading from the vehicle or on the site thereafter.

All claims for damage and/or incomplete delivery must be reported to Nuair within two days of receipt of the equipment.

I.2 Offloading and Handling from the delivery Vehicle

The weight of the unit modules and palletised items is displayed on the unit rating plate or on the packaging. Some of the modules have an uneven weight distribution, and this will be indicated by labelling where appropriate. Ensure that lifting and handling equipment is adequately rated.

Offloading and positioning of the equipment is the responsibility of the purchaser.

Spreaders should be used when lifting with slings to avoid damage to the casings. Care must be taken to ensure that slings are correctly positioned to avoid crushing and twisting of the unit castings.

Where channels and/or support frames are bolted to the underside of the unit casing, slings or fork-lift arms should be positioned to locate in the apertures in the channels. If Lifting Eyes have been supplied / fitted it is recommended that they are used.

Figure 2: Lifting.

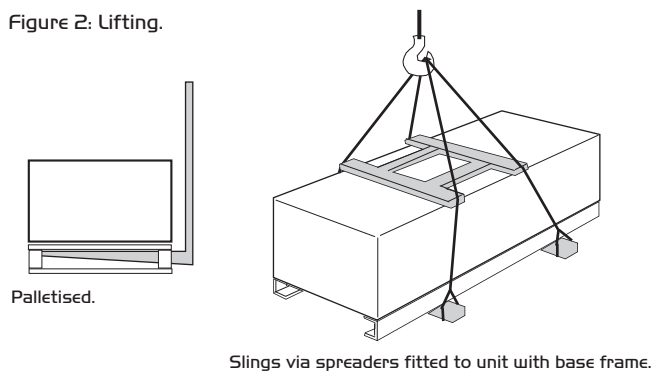

XBOXER 55 unit sections will be delivered to site in the number of sections shown below.

Unit	No. of sections
Atmosphere Side Silencer and Mixing Box	1
XBOXER 55 Central Ventilation Unit	1
Room Side Silencer	1

Each Section will be labelled with the direction of air flow. The direction convention must be observed during assembly. The units may only be operated in their intended horizontal installation plane.

The 3 units are supplied with ceiling mounting brackets attached to the top of each unit and 28 cap head fixing bolts. (see figure 7).

Units are also supplied with 4 matching external extrusion connection joints and screws with which the sections are bolted together after installation on the ceiling.

Unit and Silencer weights

	Weight (kg)	Packed Weight (kg)
XBOXER 55 Atmosphere Side Silencer With Mixing Box	153	240
XBOXER 55 Roomside Silencer	141	267
XBOXER 55 Ventilation Unit	391	516

I.3 Storage

The equipment must be stored in a dry, internal location. Ductwork connection apertures shall be sealed against the ingress of dust, water and vermin. Note that units that are intended for internal locational use only.

If the storage period is to exceed two months, contact Nuair for guidance on the appropriate “mothballing” procedures.

Do not stack units, modules or components.

2.0 Erection and Assembly

Units must be installed in accordance with good industry practice, horizontal and level on a prepared ceiling utilising the fixing brackets supplied.

Heat recovery modules and modules that incorporate cooling coils may produce condensation during use. An insulated drip tray and drain connection is provided, and should be connected to a suitable drainage point.

Provision may be required, and if so, should be made, for the fitting of a correctly sized cleanable trap to each drain connection.

Please see figure 10. for condensate connections and sizes.

Figure 3: Drainage point.

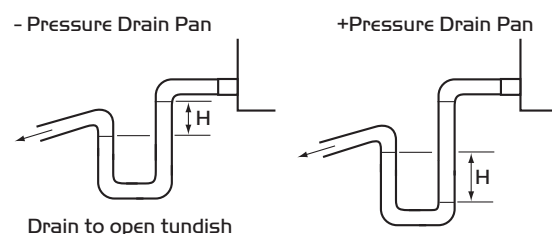

$H \text{ (mm)} = (\text{Static Pressure (Pa)} / 10) + 12$

Pipe Connection size

(Low Pressure/Cooling Condensate Run) XBOXER 55 = 15mm

Coils are tested during manufacture to 16 Bar (using dry compressed air). Operation of standard equipment is rated at PNG, if the intended system requires higher operating pressures; please contact the Nuair Technical department for advice.

Electrical connections to the unit shall be made in accordance with the appropriate product (see below); and installation wiring diagrams, and shall use appropriately sized and rated cables.

The unit rating label shows the maximum electrical load of the equipment. Connections to the unit may include single phase supply connections, and a variety of control circuits.

Control circuit connections must be segregated (i.e. routed separately) from power connections.

Only the prepared apertures in the unit casing may be used for cable entry. Do not drill or cut the unit casing for this purpose.

The equipment must be earthed and earth-bonded. Means of local isolation for maintenance purposes are generally required.

IMPORTANT

Isolation - Before commencing work make sure that the unit and Nuair control are electrically isolated from the mains supply.

3.0 Installation of the Units

Installation of the three XBOXER 55 units, including all external services and controls should be installed in accordance with the appropriate authority and MUST conform to all governing regulations e.g. CDM, CIBSE, IEE, and in strict accordance with the applicable Building Regulations.

Having decided on the correct installation position for the units, appropriate external wall grilles must be installed located to combine with the spigots on the out facing side of the Mixing Box:

The three supplied units must be installed on the ceiling in the following order:

1. The Mixing Box/Side Silencer must be installed first, positioned against the outside wall.
2. The Central Fan Unit is the second unit for installation.
3. The third unit to be installed is the Room Side Silencer.

Installation begins by removing the 28 Cap Head fixing bolts and 3 ceiling mounting brackets (one for unit see figure 4).

The final assembled position of the units on the ceiling, must allow for sufficient free space to be available adjacent to the units for future inspection, maintenance, repair and replacement.

Mark positions for mounting the ceiling brackets for each of the three units ensuring that the fixed brackets on the units will fit into the same ceiling brackets they were first removed from. (see figure 5 and 5a).

As previously mentioned the **Mixing Box/Side Silencer must be installed first**, positioned against the outside wall.

Ensure that the fixed ceiling brackets will allow for the weight of the XBOXER 55 units to be suspended from them. The first unit the Mixing Box/Side Silencer may be lifted up to be aligned and installed using the Cap Head bolts (see figure 6).

Figure 4: Removing Cap Head Bolts holding ceiling mounting brackets to the units.

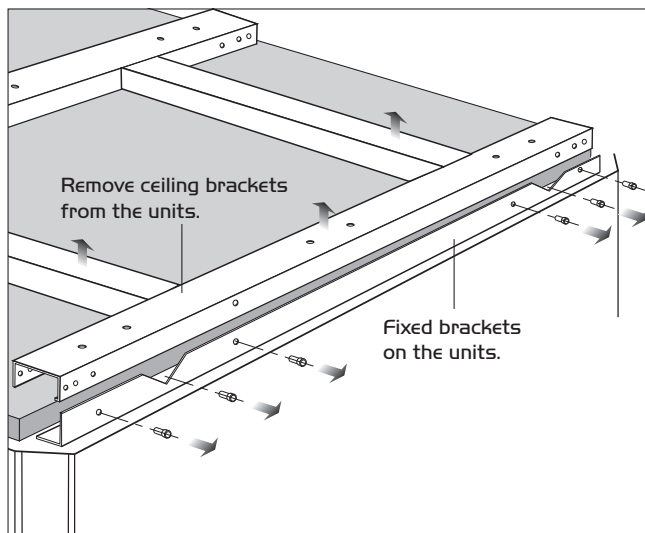

Figure 5: Mark positions for mounting the ceiling brackets (1 for each unit). External pitch (A) is 1500mm apart with a tolerance of +0/-3mm. Flatness tolerance +/-1mm.

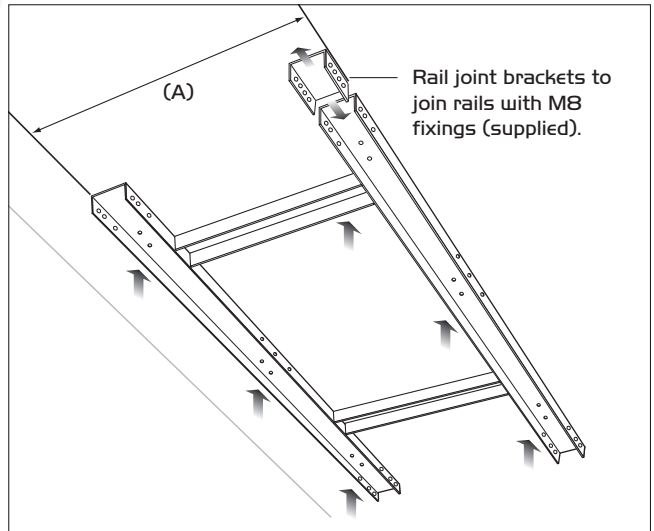

Figure 5a: The 3 ceiling bracket sets must be joined together using the 4 joining brackets and bolts supplied.

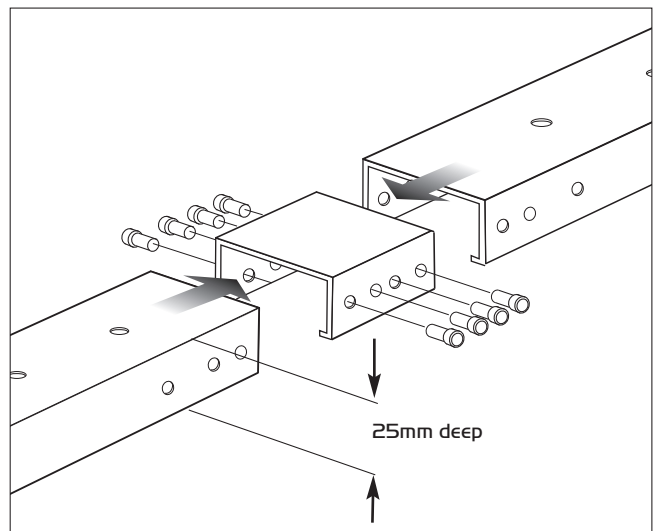
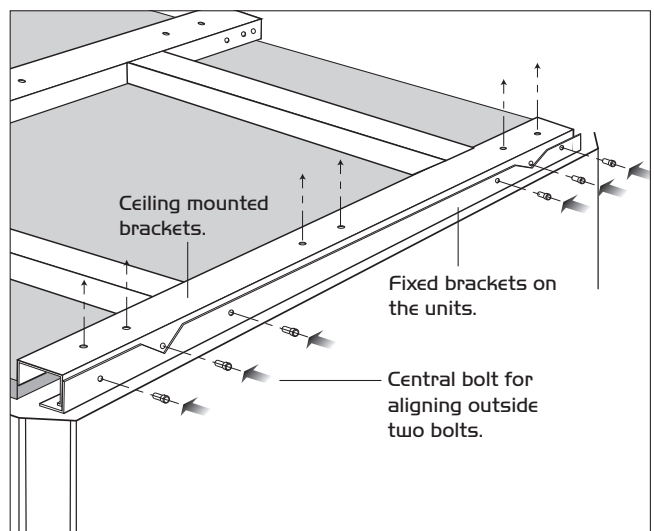

Figure 6: Position Cap Head Bolts through fixed unit bracket and ceiling mounting brackets using the central one of the three bolt holes in the "V" shape to align the outside two bolt holes.



Installation of the Units cont.

The Central Fan Unit is the second unit for installation (see figure 7), and when this unit is secured the third and final unit the Room Side Silencer should be installed using the same method.

IMPORTANT

When installing ceiling brackets ensure each one matches the specific units they were first removed from.

Figure 7: Lifting the units with appropriate equipment.

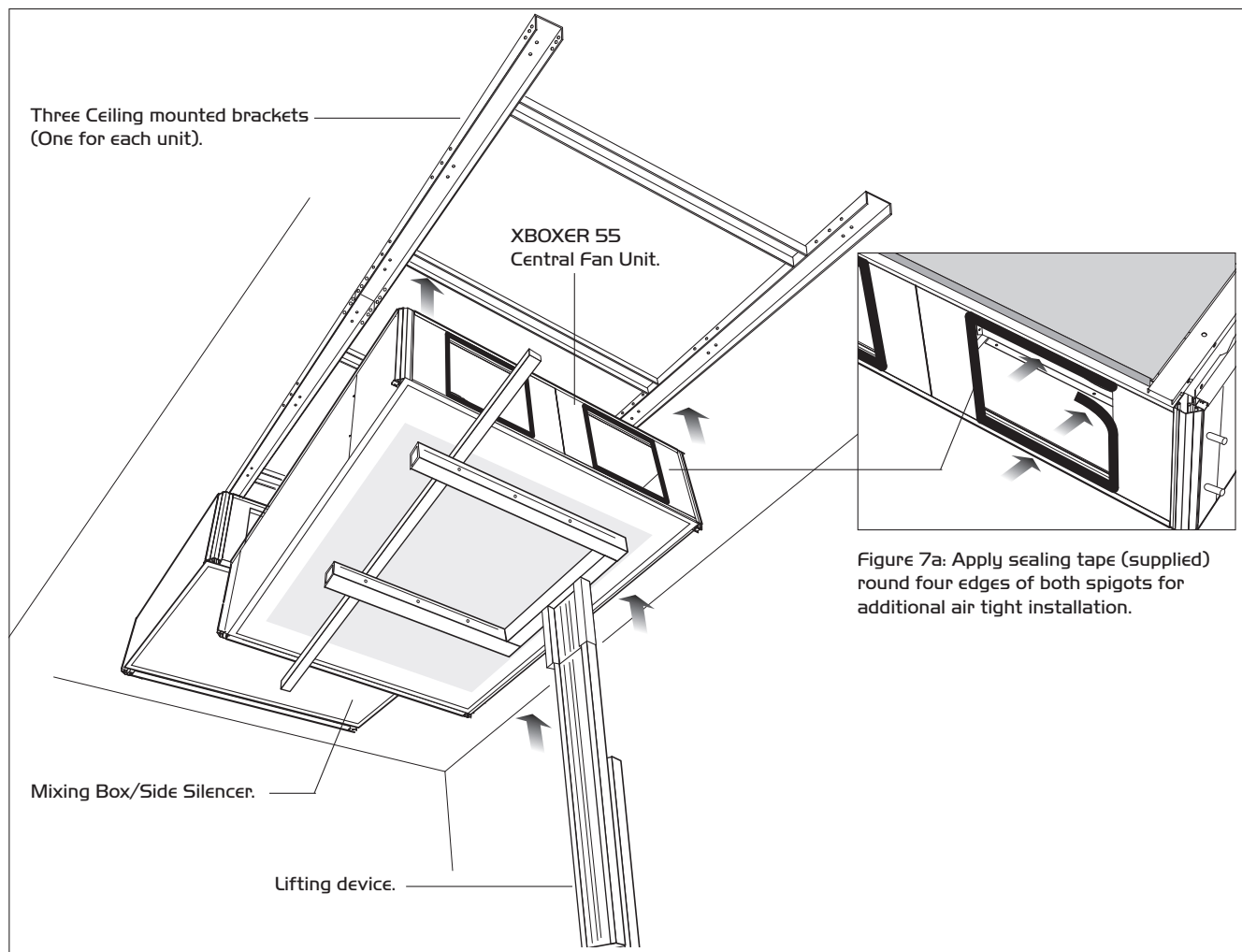

Figure 7a: Apply sealing tape (supplied) round four edges of both spigots for additional air tight installation.

It is important that the units fit tightly together so that maximum performance is achieved. On completing the installation of the three units onto the ceiling mounted brackets the units should be joined together using the supplied extrusion joining strips and screws. (see figure 8).

Figure 8: Join units together using the four supplied extrusion joining strips and screws.

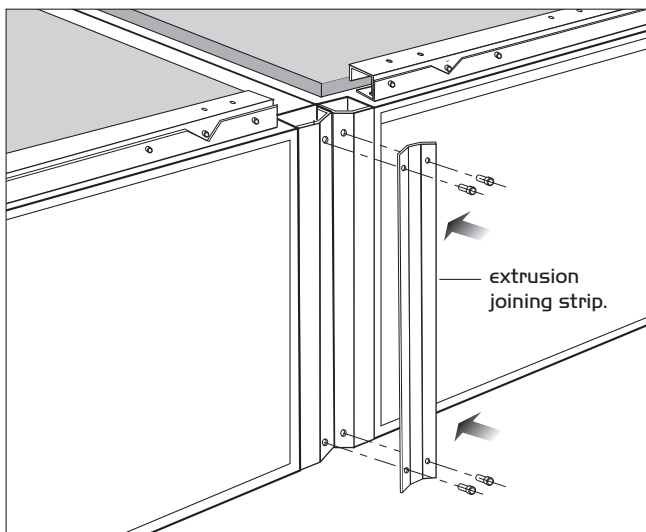

Figure 9: Three units mounted together on the ceiling.

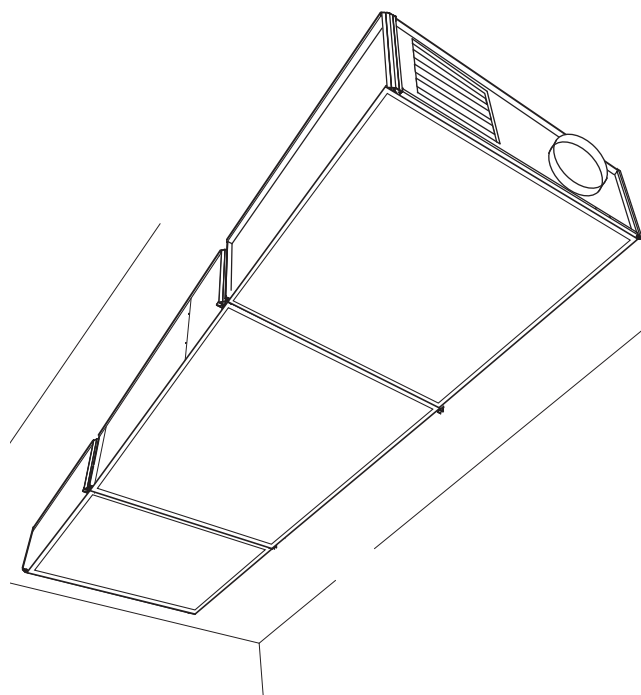
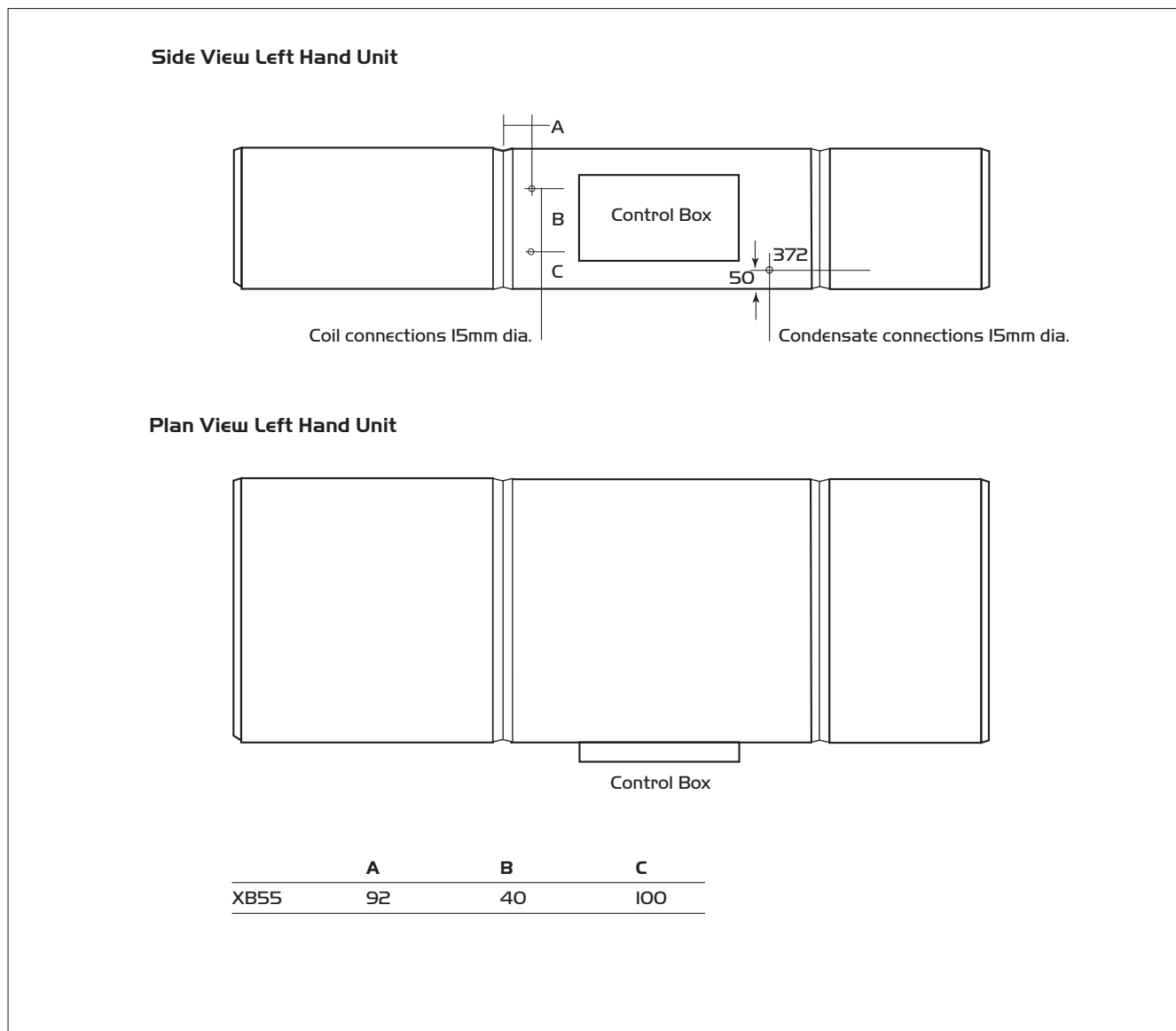

Figure 10: Coil and condensate connections to left hand unit.



4.0 Commissioning & Setting to work

(Note - not all of the components listed here are necessarily included with the equipment supplied).

4.1 Filters

Remove filter access panels (observe and note airflow direction labels), inspect filters for contamination with construction debris, replace as necessary. Replace access panels.

Filter pressure drops will depend on actual flow rate and condition. Observe and record filter pressure drops after performance commissioning.

Typically, filter “dirty” condition occurs when the initial filter “clean” readings have been increased by 125Pa.

If filter manometers, pressure switches or indicators have been fitted, they should be set or adjusted to reflect the commissioned system operation.

4.2 Heating & Cooling Coils

Water

Water coils should be connected to ensure that full counter flow exists i.e. - the entering airflow meets the return connection. All water coils should be connected with the flow at the bottom and the return at the top unless otherwise advised. Drain and bleed valves are located on the coil, others may be required in the system pipe-work depending on the installation.

Ideally, where the system is at risk of frost damage, the addition of a proprietary anti-freeze solution to the water is recommended.

Pipe-work connections should be made to the unit using appropriate techniques, and must be independently supported. The connections should be pressure tested.

DX

Direct expansion coils must be fitted with a correctly sized thermostatic expansion valve with an external equalising connection. The expansion valve phial must be fitted between the suction header connection and the equalising line.

The recommendations of the TE valve manufacturer should be referred to when locating the phial and adjusting the superheat. In all cases, settings should be in accordance with the recommendations of the manufacturer of the refrigeration equipment.

4.3 Fan Sections

Access to the fan section is via lift off panels. (see figures 11 & 12).

For non-Ecosmart units, wiring to the fan motor / unit terminal box should be mechanically protected and in made in accordance with the details on the motor name plate and diagram attached to the unit.

With the unit electrically isolated, rotate the fan impeller / drive manually, checking that it spins freely. Check all fixings are secure.

Units must not be operated without all access panels in place – damage to equipment or injury to personnel may result.

Units must not be operated unless control interlocks are in place – damage to equipment may result.

Test run motor for condition and correct rotation.

Check that the correct current overloads are fitted and that the current being drawn does not exceed the motor nameplate value. Excessive current normally indicates that the ductwork system resistance is different to design.

4.4 Access to fan unit

Access to the fan sections on the non control side and controls side of the unit is shown in figures 11 and 12.

Access to the Dampers and actuators is shown in figures 13. in section 4.5.

IMPORTANT

Isolation - Before commencing work make sure that the unit, switched live and Nuair control are electrically isolated from the mains supply.

Figure 11: Non control side (Right hand unit) access of unit to condensate pumps, heat exchanger bypass actuator,



Figure 11a, 11b and 11c: Remove non control centre side access panel by removing the four bolts (2 x 2) on rear of panel and disconnect condensate pipe.

Figure 11c.

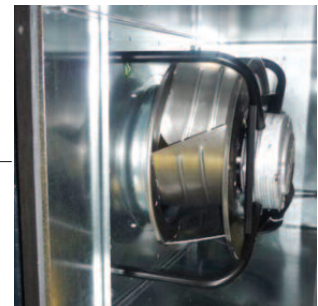
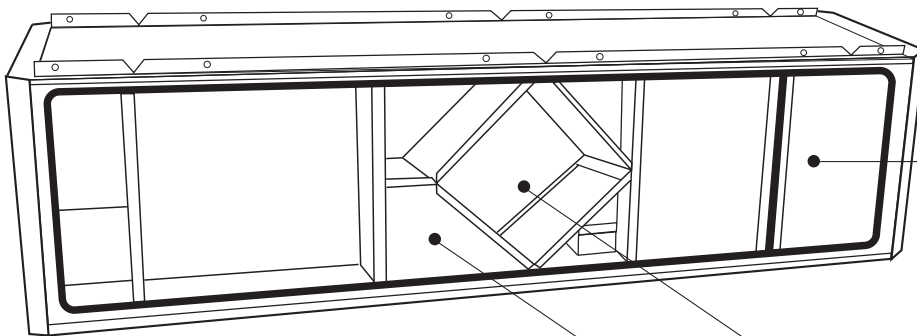

Figure 11d: Extract fan.



Figure 11f: Remove where fitted.

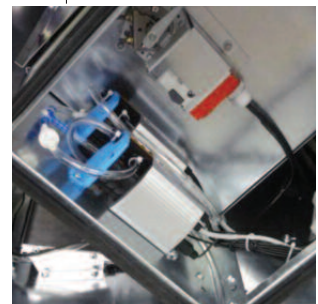

Figure 11g: Condensate pump and bypass actuator fitted as standard.

Figure I2: Control side (Right hand unit) access of unit to filter, supply fan, controls and coils.

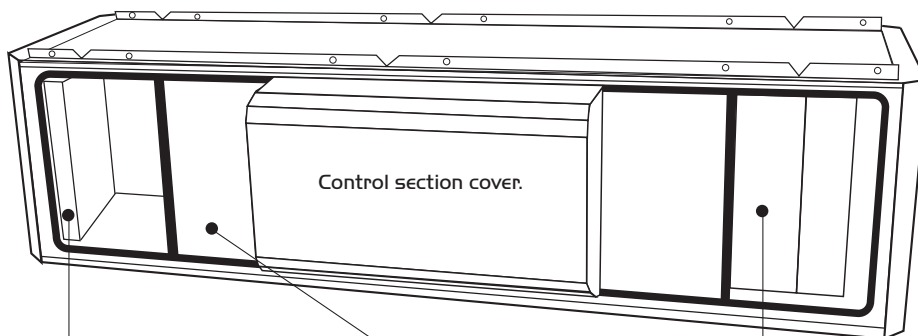

Figure I2a: Remove panel for access to filter and supply fan.



Figure I2b: Removable fanplate for supply fan removal.

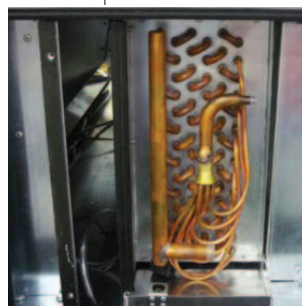

Figure I2c. Access to coils.

4.5 Access to Dampers and Actuators in the Atmospheric Silencer and Mixing Box

Figure I3: (Right hand unit) access of Atmospheric Silencer and Mixing Box. Remove access panel, pod and frame by sliding out to reveal terminal box for Mixing Box actuators.



Figure I3a: Actuators are removed in sequence from accessibility.

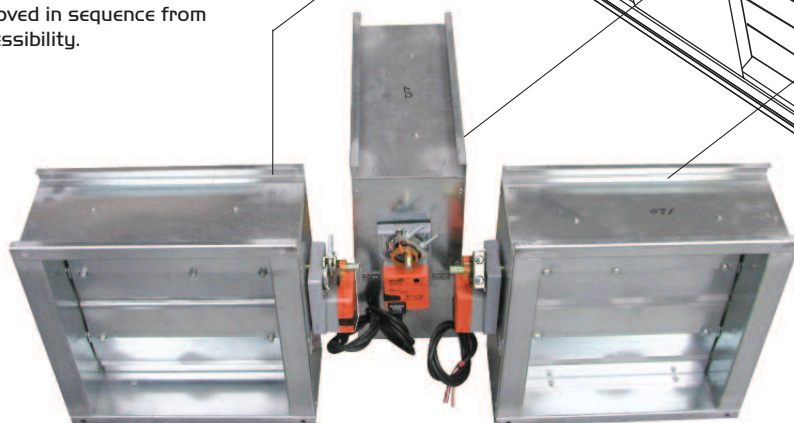
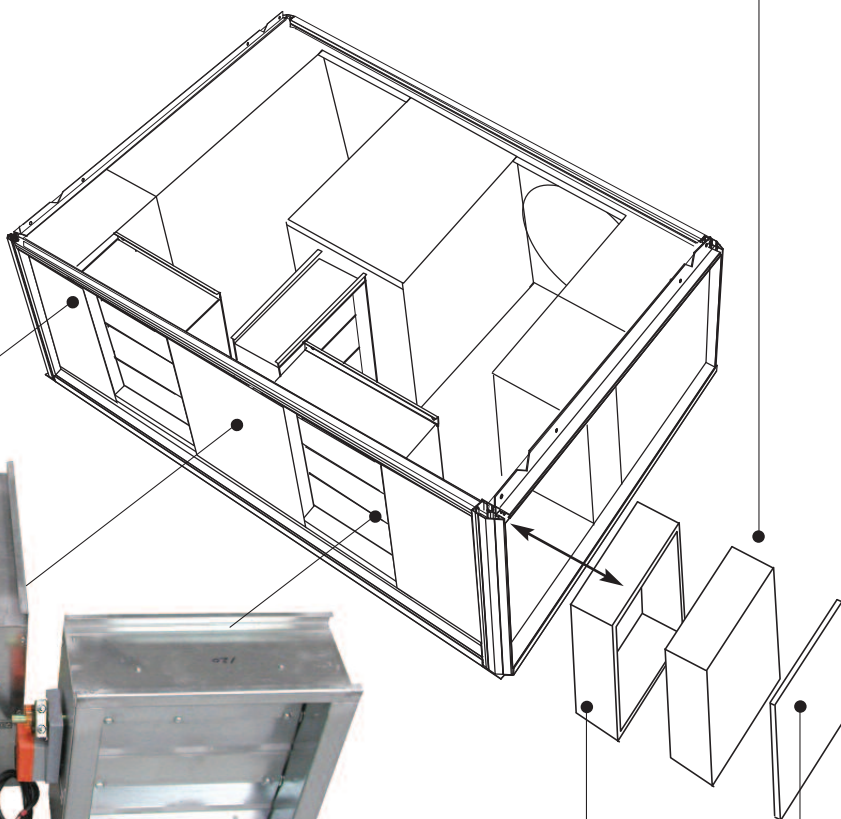

Figure I3b: View of dampers and actuators as installed in the unit. Removal is via fixings top and bottom - then slides towards operative.

Pod and insulation inside pod.

Access panel.

5.0 Wiring (Units with Ecosmart Control)

The electrical wiring must be carried out by competent persons, in accordance with good industry practice and should conform to all governing and statutory bodies i.e. IEE, CIBSE, COHSE etc.

Connections

a) Control Connections

Net - the 4 IDC plug-in connectors are provided for the connection of compatible sensors, manual controls and for linking the fans together under a common control. If more than 4 connections are required, the junction box (product code ES-JB) should be used (see data cable installation).

Switch Live (SL) terminal - A signal of 100-230V a.c. will activate the fan (required at each control).

Note that a signal from an isolating transformer will produce an unpredictable result and is not recommended.

b) Damper Connections

OP - 230V 50Hz 1A max supply to open the damper

CL - 230V 50Hz 1A max supply to close the damper

N - Neutral supply to damper

RET - 230V ac return signal from the damper limit switch indicates the damper has reached its operating position.

If the return signal is not present, the fan will wait for 1 minute before starting.

Note: If a damper is not fitted, connect a link wire from OP to RET. This will cancel the delay.

Where units are supplied in modular sections, it will be necessary to install and connect mains wiring between controls and devices such as motorised dampers, it may also be necessary to install and connect mains wiring between sensors and actuators.

Depending on final damper location, extension of the cable looms may be required.

c) Volt Free Relay Contacts

Note that the volt free contacts are not fused. If these are used to power any external equipment, the installer must provide adequate fusing or other protections.

These contacts are rated at 5A resistive, 0.5A inductive.

Run connections - These contacts are closed when the fan is running.

Fault connections - No fault = the contacts are closed. Fault = the contacts are opened.

Heat demand - contacts closed when heating is selected.

d) Data Cable Installation

A 4-core SELV data cable is used to connect devices.

Do not run data cable in the same conduit as the mains cables and ensure there is a 50mm separation between the data cable and other cables. The maximum cable run between any two devices is 300m when it is installed in accordance with the instructions.

Please note that the total data cable length used in any system must be less than 1000m. Keep the number of cable joints to a minimum to ensure the best data transmission efficiency between devices.

e) Maximum Number of Devices

The maximum number of devices (including fans) that can be connected together via the cable is 32, irrespective of their functions.

f) Other Low Voltage Cables

Follow the basic principle (as d). Keep the cable run as short as possible, less than 50 metres. Use screened cable if cable length is more than 2m.

Electrical Details

Fans without Electric Heater		Fans with Electric Heater	
Unit Code	flc (amps)	Unit Code	flc (amps)
XB55*N/L	2 X 3.5	XB55*E	18.7

Wiring diagrams for units with Ecosmart Control

Wiring with Ecosmart fan only control. Figure I4.

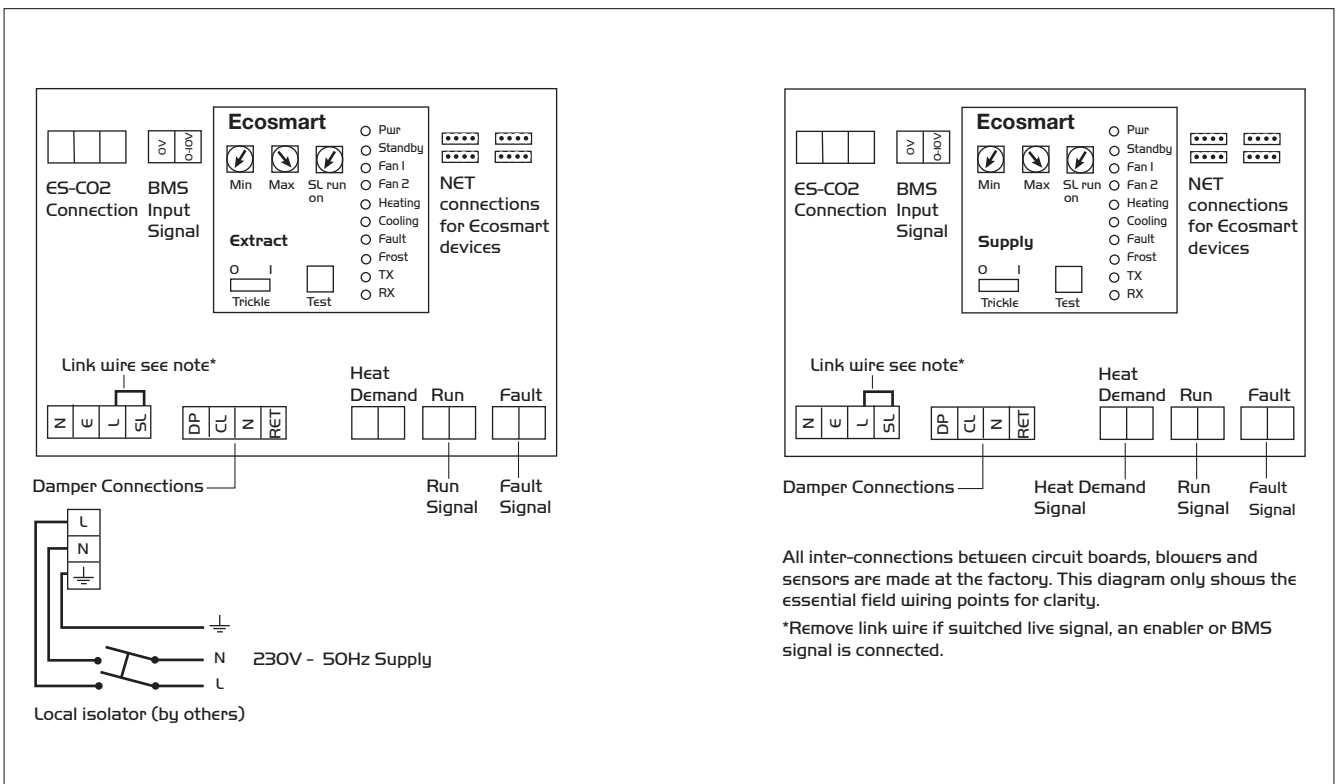

Wiring diagrams for units with Ecosmart Control cont.

Wiring with Ecosmart control and electric heater. Figure 15.

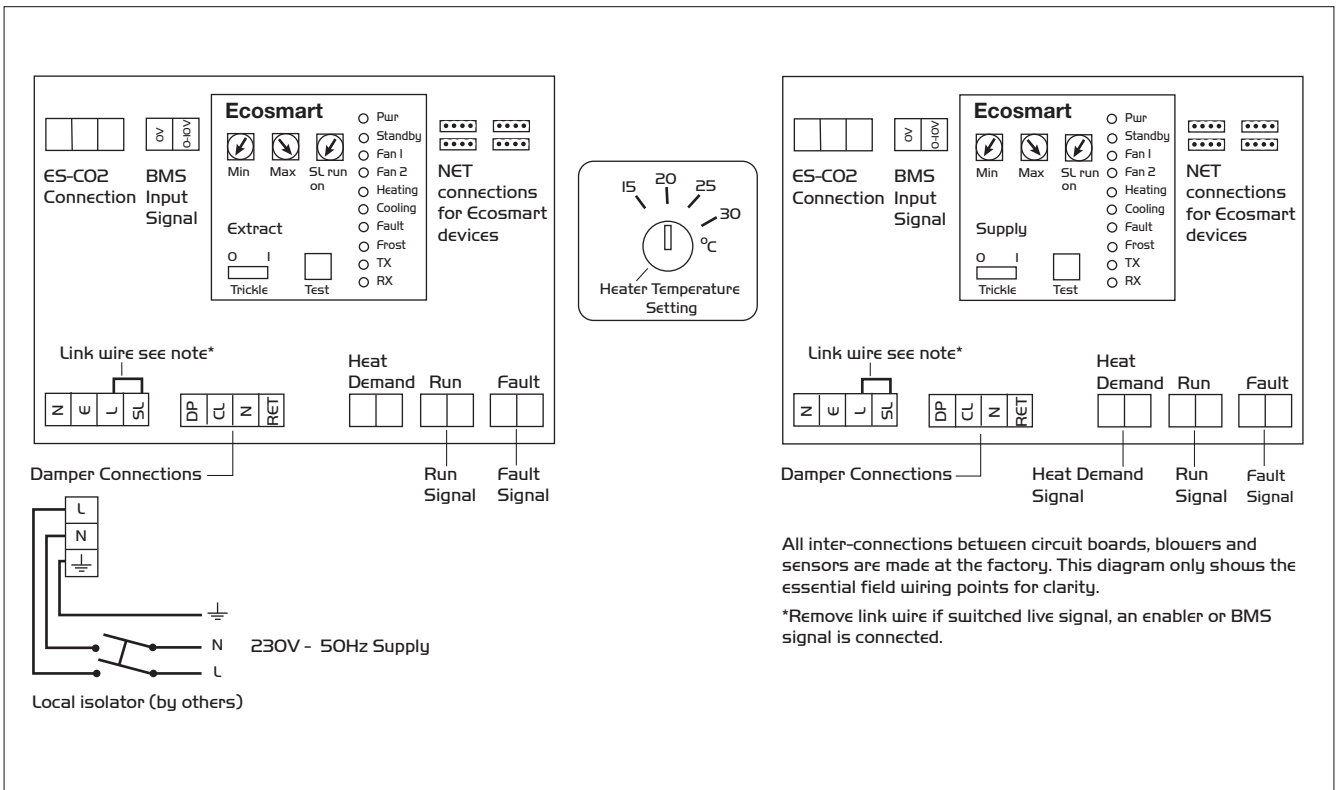

Wiring with Ecosmart fan and LPHW coil control. Figure 16.

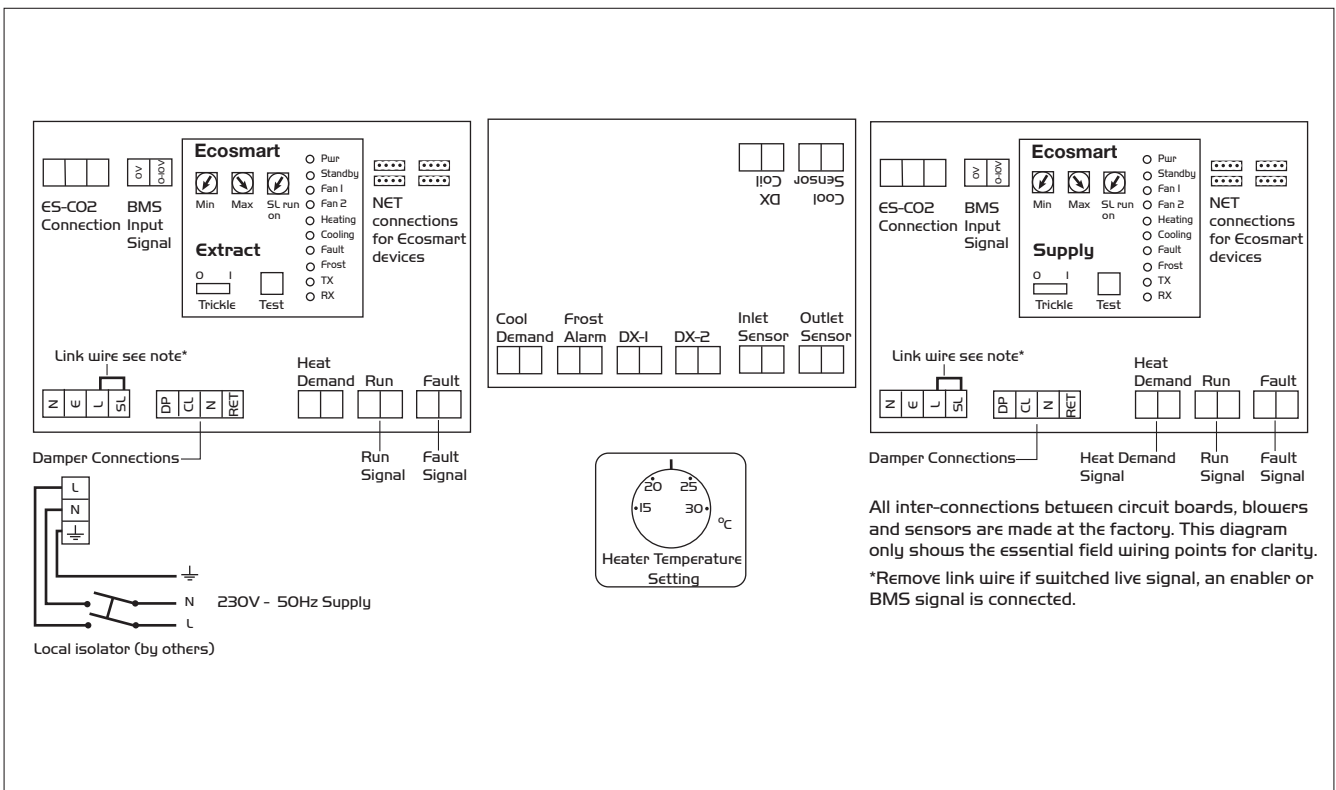

6.0 Setting to Work Using the Test Button

The test button allows the individual blowers within the unit to be checked for its operation. If the fan is running already, press the button once to stop the fan, press again to switch on the fan.

Note that the fan will return to normal operation after 30 seconds.

IMPORTANT

Note: this unit contains two fan units and two controls. Generally, it is recommended that the two fans are operated together (factory default arrangement), but the fans are capable of independent operation if required.

LED Indication

PWR	GREEN: Power on & OK,
Standby	LED on when fan is not running.
Fan 1	GREEN: Fan 1 is running, RED: Fan 1 faulty.
Fan 2	GREEN: Fan 2 is running, RED: Fan 2 faulty.
Heating*	GREEN: Heating selected RED: Heating faulty.
Cooling*	Not applicable. See note.
Fault	LED on when a fault is present on unit.
Frost*	Not applicable. See note.
TX	LED on when the controller is transmitting data.
RX	LED on when the controller is receiving data.

* Note that the control panel is common to all the Ecosmart products and will have indicators for functions that are not available in this particular fan. However these indicators will not be illuminated.

BMS Input Signals

The system's response to a 0-10V dc BMS signal is given in the following table.

Note the BMS signal will override any sensors and user control connected in the system. The voltage tolerance is +/- 125mV and is measured at the fans terminal.

	Ventilation mode	Cooling mode*	Heating mode*
Local control	0.00	-	-
OFF / trickle	0.25	-	-
Speed 1	0.50	0.75	1.00
Speed 2	1.50	1.75	2.00
Speed 3	2.50	2.75	3.00
Speed 4	3.50	3.75	4.00
Speed 5	4.50	4.75	5.00
Speed 6	5.50	5.75	6.00
Speed 7	6.50	6.75	7.00
Speed 8	7.50	7.75	8.00
Speed 9	8.50	8.75	9.00
Speed 10	9.50	9.75	10.00

* Only available on relevant unit

Settings

Setting the maximum air flow

i) Ensure the power supply is switched off and that a link wire is connected from the supply L to the SL terminal. Unplug all items connected to the 'Net' connectors.

ii) Switch on the power supply.

iii) Wait for the fan to complete its self-test operation.

Measure the airflow using standard commissioning instruments at a suitable point in the ductwork. If adjustment is required, rotate the pot marked 'MAX' to obtain the desired airflow.

Setting the minimum trickle airflow (nominal 40%)

i) Repeat the same procedure as for maximum airflow above but without the link wire between supply L and SL terminal. Ensure the trickle switch is in the 'ON' position. Adjustment must be made on the pot marked 'Min'.

ii) Note that the minimum setting (nominally 40%) must be below the maximum setting, otherwise minimum setting will be automatically set to be the same as the maximum.

Setting the overrun time

A switched live of 100-230V at terminal SL will activate the fan. When the switched live signal is removed the fan will overrun for period set by the dial 'SL run on' - adjust the desired overrun time by rotating clockwise.

Setting the trickle ventilation facility

Slide the 'trickle' switch 0 = Off, 1 = On. With 'trickle' on and power to unit the fan will run at minimum speed until the switch live signal activates it to boost.

Setting the 'air off' temperature

The adjustment knob is located in the control pack and must be set to the desired 'air off' temperature.

Figure 17.

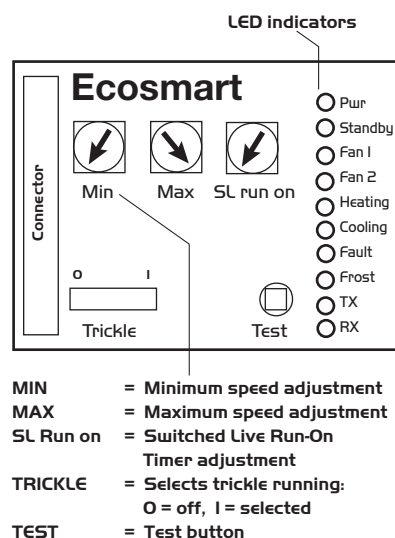

8.0 Wiring diagrams for Mixing Box (control by others)

The mixing box incorporates a supply, extract and mixing damper. The connection of these dampers is to an externally mounted termination box, situated on the access side of the mixing box.

The mixing box is supplied with three actuator options: 240VAC, 24VAC/DC or 24VAC/DC with 0-10VDC modulation control.

Note: The operational control for these dampers is by others and not a function of the Ecosmart control if fitted.

Wiring for 240V AC Actuator. Figure 20.

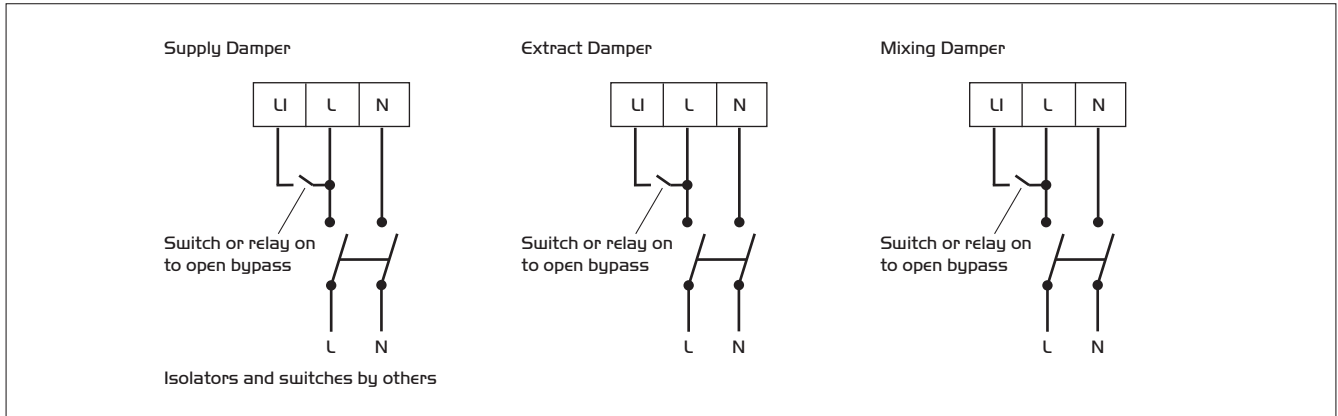

Wiring for 24V AC/DC Actuator. Figure 21.

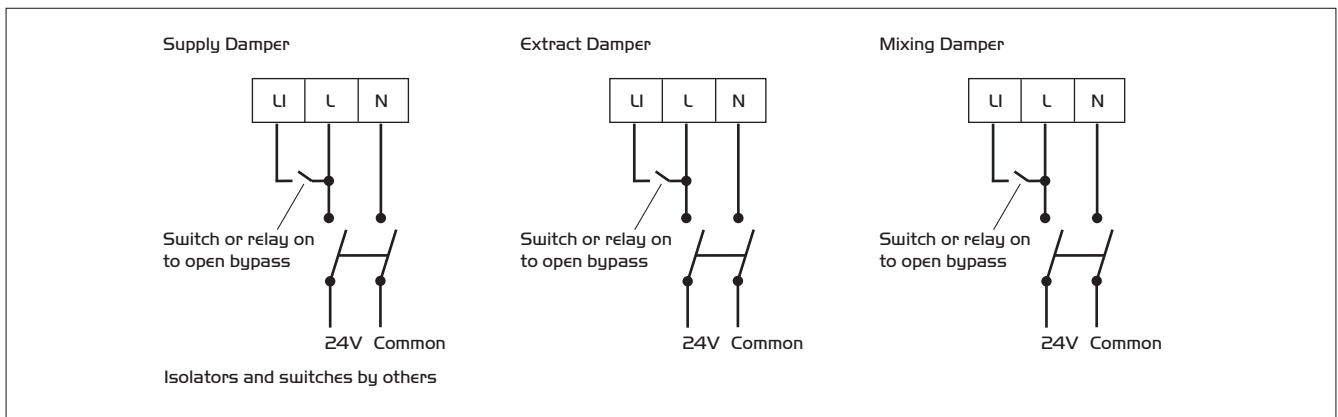

Wiring for 24V AC/DC with 0-10V DC Modulating Control Actuator. Figure 22.

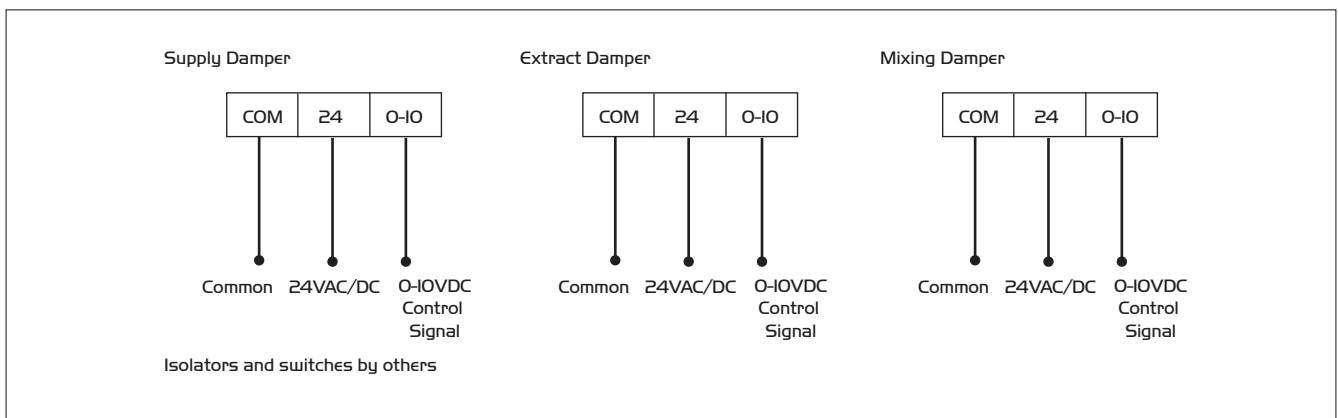

9.0 Maintenance

It is recommended that PPE is always used during the maintenance of Air Handling Equipment – gloves, eye shields and respiratory mask.

IMPORTANT

Isolation - Before commencing work make sure that the unit and Nuair control are electrically isolated from the mains supply.

In some Ecosmart units and in some third party controls, variable speed drives (inverters) are used to provide fan speed control. After the fan is isolated, allow at least 5 minutes for the capacitors in the inverter to discharge before commencing any work on the unit.

9.1 Dampers

At regular intervals check that the blades move freely.

9.2 Filters

Disposable filters should be changed when an appropriate pressure drop is achieved.

9.3 Heating and Cooling Coils

Coils should have their finned surface examined for accumulation of dirt, lint and biological contaminants or similar. If necessary, wash down affected areas with a mild detergent solution and a soft brush. Care should be taken not to damage the finned surface, and any cleaning fluids should be rinsed away with water. A compressed air line may be used to blow out any solids between fins. Do not probe the coil fin block with metal objects as damage may cause leaks.

Drain lines should be checked to ensure that they are unobstructed and free draining. Traps should be checked that they are fully primed and functioning.

Drain pans should be flushed out periodically to remove contamination.

Note: The unit application may require particular attention to this item – Check with Building Management personnel for details.

9.4 Recuperator/Plate Heat Exchanger

The recuperator block is normally protected from dust and contamination by upstream pre-filters. It is possible to clean the unit with compressed air in the case of dust deposits or by spraying with a mild detergent solution for grease deposits. Solvents, strong alkaline, acidic or any products that may be aggressive to aluminium should not be used. Do not use cleaning water over 50°C.

Drain lines should be checked to ensure that they are unobstructed and free draining. Traps should be checked that they are fully primed and functioning.

Drain pans should be flushed out periodically to remove contamination, and chemical treatments may be used to provide protection between service visits.

Note: The unit application may require particular attention to this item – Check with Building Management personnel for details.

9.5 Fans and Motors

Fan bearings should be manually checked at regular intervals for condition. Standard fan bearings are supplied as 'sealed for life' and have an anticipated life of 40,000 hours.

Motors have an enclosed bearing housing and are pre-greased for life.

Check all fixings are secure.

9.6 General

Inspect all internal and external surfaces to check for corrosion or peeling of painted surfaces.

Thoroughly clean affected areas with a wire brush, apply a coat of zinc rich primer or similar, and re-touch with suitable finishing paint. Ensure tightness of all nuts, bolts, and fixings.

Check all components for general condition.

10.0 Service

Service schedule (typical – will depend on site conditions)

	6 MONTHS	12 MONTHS
FILTERS	✓ or	✓
DAMPERS		✓
DAMPER ACTUATORS		✓
VENT WATER COILS		✓
COIL FINNED SURFACES		✓
CHECK DRAIN LINES + DRIP TRAY	✓	✓
CLEAN & FLUSH DRAIN PANS	Building Schedule ?	✓
NUTS, BOLTS, FIXINGS SECURE		✓
FAN BEARINGS		✓
ELECTRIC HEATERS		✓
ELECTRICAL WIRING		✓
FAN IMPELLER		✓
GENERAL		✓

11.0 Warranty

XBOXER 55 units fitted with Ecosmart control carry a 5 year warranty. Units without controls carry a 2 year warranty. The warranty starts from the day of delivery and includes parts and labour for the first year. The remaining period covers replacement parts only.

This warranty is void if the equipment is modified without authorisation, is incorrectly applied, misused or not installed commissioned and maintained in accordance with the details contained in this manual and general good practice.

12.0 Spares

Spare parts and replacement components, and general advice are available from the Nuair Ltd Service department.



Telephone 029 2085 8585
Fax 029 2085 8586

DECLARATION OF INCORPORATION AND INFORMATION FOR SAFE INSTALLATION, OPERATION AND MAINTENANCE

We declare that the machinery named below is intended to be assembled with other components to constitute a system of machinery. All parts except for moving parts requiring the correct installation of safety guards comply with the essential requirements of the Machinery Directive. The machinery shall not be put into service until the system has been declared to be in conformity with the provisions of the EC Machinery Directive.

Designation of machinery: XBOXER 55
Machinery Types: Supply & Extract fans with Heat Recovery
Relevant EC Council Directives: 2006/42/EC (Machinery Directive)
Applied Harmonised Standards: BS EN ISO 12100-1, BS EN ISO 12100-2, EN60204-1, BS EN ISO 9001, BS EN ISO 13857
Applied National Standards: BS848 Parts 1, 2.2 and 5
 Note: All standards used were current and valid at the date of signature.

Signature of manufacture representatives:

Name:	Position:	Date:
1) C. Biggs 	Technical Director	1. 09. 11
2) A. Jones 	Manufacturing Director	1. 09. 11

INFORMATION FOR SAFE INSTALLATION, OPERATION AND MAINTENANCE OF NUAIRE VENTILATION EQUIPMENT

To comply with EC Council Directives 98/37/EC Machinery Directive and 2004/108/EC (EMC).

To be read in conjunction with the relevant Product Documentation (see 2.1)

1.0 GENERAL

1.1 The equipment referred to in this Declaration of Incorporation is supplied by Nuairé to be assembled into a ventilation system which may or may not include additional components.
 The entire system must be considered for safety purposes and it is the responsibility of the installer to ensure that all of the equipment is installed in compliance with the manufacturers recommendations and with due regard to current legislation and codes of practice.

2.0 INFORMATION SUPPLIED WITH THE EQUIPMENT

2.1 Each item of equipment is supplied with a set of documentation which provides the information required for the safe installation and maintenance of the equipment. This may be in the form of a Data sheet and/or Installation and Maintenance instruction.
 2.2 Each unit has a rating plate attached to its outer casing. The rating plate provides essential data relating to the equipment such as serial number, unit code and electrical data. Any further data that may be required will be found in the documentation. If any item is unclear or more information is required, contact Nuairé.
 2.3 Where warning labels or notices are attached to the unit the instructions given must be adhered to.

3.0 TRANSPORTATION, HANDLING AND STORAGE

3.1 Care must be taken at all times to prevent damage to the equipment. Note that shock to the unit may result in the balance of the impeller being affected.
 3.2 When handling the equipment, care should be taken with corners and edges and that the weight distribution within the unit is considered. Lifting gear such as slings or ropes must be arranged so as not to bear on the casing.
 3.3 Equipment stored on site prior to installation should be protected from the weather and steps taken to prevent ingress of contaminants.

4.0 OPERATIONAL LIMITS

4.1 It is important that the specified operational limits for the equipment are adhered to e.g. operational air temperature, air borne contaminants and unit orientation.
 4.2 Where installation accessories are supplied with the specified equipment e.g. wall mounting brackets. They are to be used to support the equipment only. Other system components must have separate provision for support.
 4.3 Flanges and connection spigots are provided for the purpose of joining to duct work systems. They must not be used to support the ductwork.

5.0 INSTALLATION REQUIREMENTS

In addition to the particular requirements given for the individual product, the following general requirements should be noted.

5.1 Where access to any part of equipment which moves, or can become electrically live are not prevented by the equipment panels or by fixed installation detail (eg ducting), then guarding to the appropriate standard must be fitted.
 5.2 The electrical installation of the equipment must comply with the requirements of the relevant local electrical safety regulations.
 5.3 For EMC all control and sensor cables should not be placed within 50mm or on the same metal cable tray as 230V switched live, lighting or power cables and any cables not intended for use with this product.

6.0 COMMISSIONING REQUIREMENTS

6.1 General pre-commissioning checks relevant to safe operation consist of the following:
 Ensure that no foreign bodies are present within the fan or casing.
 Check electrical safety. e.g. Insulation and earthing.
 Check guarding of system.
 Check operation of Isolators/Controls.
 Check fastenings for security.
 6.2 Other commissioning requirements are given in the relevant product documentation.

7.0 OPERATIONAL REQUIREMENTS

7.1 Equipment access panels must be in place at all times during operation of the unit, and must be secured with the original fastenings.
 7.2 If failure of the equipment occurs or is suspected then it should be taken out of service until a competent person can effect repair or examination. (Note that certain ranges of equipment are designed to detect and compensate for fan failure).

8.0 MAINTENANCE REQUIREMENTS

8.1 Specific maintenance requirements are given in the relevant product documentation.
 8.2 It is important that the correct tools are used for the various tasks required.
 8.3 If the access panels are to be removed for any reason the electrical supply to the unit must be isolated.
 8.4 A minimum period of two minutes should be allowed after electrical disconnection before access panels are removed. This will allow the impeller to come to rest.
NB: Care should still be taken however since airflow generated at some other point in the system can cause the impeller to "windmill" even when power is not present.
 8.5 Care should be taken when removing and storing access panels in windy conditions.

Technical or commercial considerations may, from time to time, make it necessary to alter the design, performance and dimensions of equipment and the right is reserved to make such changes without prior notice.