



# MRXBOX95-HUM

## Low Voltage Humidistat Sensor

### Installation and Maintenance



**IMPORTANT! Please refer to the installation instructions of the fan to check the compatibility of this sensor.**

## 1.0 Introduction

Designed to be compatible with the Ecosmart system, this humidistat unit is supplied with a pre-plugged, 10 metre length of communications cable. Note: longer lengths are available if required.

The sensor operates with low voltage with power supplied from the fan unit via the communications cable.

The Humidistat will enable the Ecosmart fan when the measured humidity level is 2% above the set point and will stop the fan when the humidity is at or below set point.

### 1.1 Parts Check List

- MRXBOX95-HUM Humidistat Sensor
- 1 off 10 metre length of plugged cable

## 2.0 Installation

### 2.1 Installing the Sensor

The sensor unit should be installed away from any direct source of heat (e.g. radiators) and areas where it would be subjected to water spray.

The Sensor is supplied complete with 10 metres of connecting cable with plugs attached. Sensors are also supplied with all fixings and are clipped into a back plate wall mounting bracket.

- Fix one end of the 10m cable to the Ecosmart connection point.
- Select a suitable location for the sensor and arrange the cable in position. Leave approx. 75mm of the cable free at the mounting point to ease the connection of the plug (Figure 1).
- Carefully separate the sensor from the back plate using a small screwdriver (Figure 2) Note: the sensor will remain connected by its internal cable.
- Release this cable from the bracket by simply pulling the plug off the socket pins in the back plate.
- Before fixing the back plate to the wall, connect the wall fixed cable end plug to the upper set of pins on the bracket (Figure 3).
- Note: Ensure the colour code matches** when fitting the plug onto the pins.
- Arrange the cable so it lies in the cable slot at the top of the back plate moulding and fix the bracket to the wall surface using the screws supplied.
- The sensor plug can now be connected into the back plate Note: check the colour code matching when fitting the plug onto the pins. Clip the sensor body in the back plate arms and adjust the sensor body to the desired position.

### 2.2 Data Cable Installation

A 4-core data cable is used to connect devices.

Do not run data cable in the same conduit as the mains cables and ensure there is a 50mm separation between the data cable and other cables. The maximum cable run between any two devices is 300m when it is installed in accordance with the instructions.

Please note that the total data cable length used in any system must be less than 1000m. Keep the number of cable joints to a minimum to ensure the best data transmission efficiency between devices.

## 3.0 Operation

### 3.1 Adjusting Sensor Set Points (65-85 %RH)

Assuming the sensor(s) are installed, adjustment of the set points achieved by tilting the sensor forwards which exposes the adjustment aperture (Figure 5).

Using a small screwdriver, gently turn the dial either clockwise or anti-clockwise to increase or decrease the set point.

When adjustments are made to the sensor, the LED light on the sensor front will flash on and off to show the set point. First, green flashes will indicate the set point in TENS and then red flashes will indicate UNITS.

For example seven green flashes and three red flashes show a RH set point of 73%.

### 4.0 Maintenance

The unit does not require any maintenance. However, for optimum performance, it is advisable to remove any accumulated dust with a low power vacuum cleaner.

**NOTE: Installation and Maintenance of the equipment must be as directed in the instructions provided with the unit.**

Figure 1.

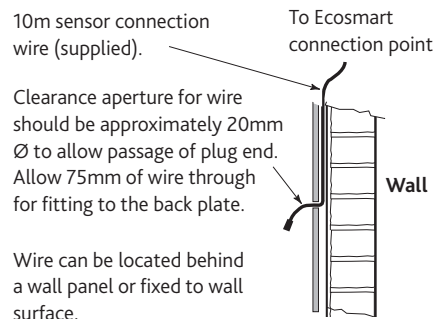

Figure 2.

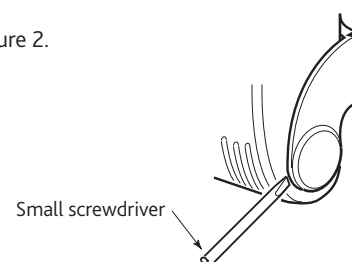

Figure 3.

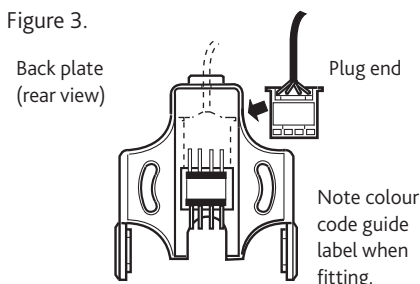

Figure 4.

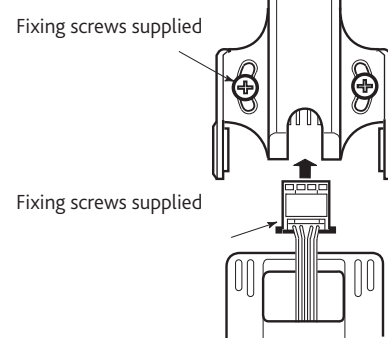
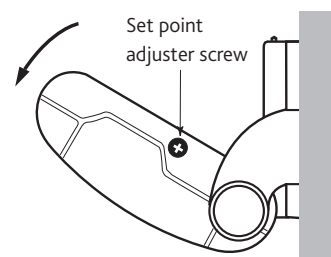

Figure 5.



## 5.0 Warranty

The 5 year warranty starts from the day of delivery and includes parts and labour for the first year. The remaining 4 years covers replacement parts only.

This warranty is void if the equipment is modified without authorisation, is incorrectly applied, misused, disassembled, or not installed, commissioned and maintained in accordance with the details contained in this manual and general good practice.

The product warranty applies to the UK mainland and in accordance with Clause 14 of our Conditions of Sale.

Customers purchasing from outside of the UK should contact Nuaire International Sales office for further details.

## 6.0 After Sales Enquiries

For technical assistance or further product information, including spare parts and replacement components, please contact the After Sales Department.

Telephone 02920 858 400  
[aftersales@nuaire.co.uk](mailto:aftersales@nuaire.co.uk)

