

# NUAIRE

## SINGLEPAK

### In Line Single Fan

## Installation and Maintenance

### NUAIRE

Nuair Limited  
Western Industrial Estate, Caerphilly,  
Mid Glamorgan. CF83 1XH United Kingdom  
Telephone 029 2088 5911  
Facsimile No. 029 2088 7033  
Email: info@nuaire.co.uk  
www.nuaire.co.uk

Leaflet No. 671024  
NOVEMBER 2001

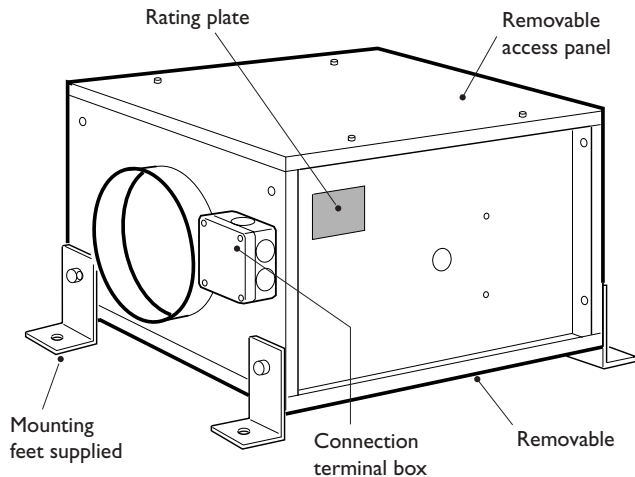

Fig. 1 General view of fan unit

## Introduction

The Singlepak range of In Line singlefans are rectangular in section and manufactured in galvanised steel. The fan units and the matching ancillaries are fitted with circular spigots. Fans are available with duties up to 0.95m<sup>3</sup>/s. and are suitable for air extract or air input.

Integral backdraught shutters fitted as standard. Access panels top and bottom simplify installation and maintenance.

Units are supplied complete with heavy gauge steel mounting feet. Singlepak may be installed at any angle **except vertically blowing downwards and inverted horizontally.**

QSP (Quiet Singlepak) unit cases have fire resistant acoustic lining.

Fan is easily serviced after removal of the access panel. Each assembly is electrically terminated in a connector box inside the unit casing. Supply cable enters unit through cable grommet provided on case side.

The motors have thermal overload protection and sealed for life bearings. Forward curved centrifugal impellers are fitted.

A matching range of ancillaries including silencers, filters and heaters is available.

Auto Transformer or Electronic speed controls are available. A run on timer is available giving automatic operation when linked to a light switch or similar source.

## Handling

Always handle the units carefully to avoid damage and distortion. If mechanical aids are used to lift the unit, spreaders should be employed and positioned so as to prevent the slings, webbing etc. making contact with the casing.

## Mounting

The method of mounting used is the total responsibility of the installer.

Note that the unit is supplied with flange holes, see fig. 1. The mounting feet (supplied) can be attached at any of these points and the unit may be installed at any angle.

## Contents

## Page

Introduction .....	1
Installation .....	1
Testing after Installation .....	1
Dimensions .....	2
Motor Details .....	3
Electrical Diagrams .....	4
Maintenance .....	6
Replacement of parts .....	6
Certification .....	8

## Installation

Units should always be positioned with sufficient space to allow removal of the access covers and subsequent removal of fan and motor assemblies etc.

Note: when the unit is mounted horizontally the correct orientation must be observed as indicated by direction labels on the side of the unit case. **Note Do not install the unit inverted.**

## Speed Controls and Remote Fan Failure Indicator.

These controls may be mounted onto any firm surface using the fixing holes provided in the base. Drill and plug the mounting surface, positioning the control or indicator so that the cover screws remain accessible. This is particularly important if a battery of controls is being installed. Fix the unit using suitable woodscrews (not supplied). For wiring purposes, the control or indicator cover has knock out slots for cable entry to suit up to 20mm conduit.

## Testing after Installation

Ensure that the Singlepak unit and Control / Remote Fan Failure Indicator, as relevant, are fitted.

Switch on and check that the Singlepak unit runs satisfactorily.

If a NuAire Transformer speed control has been installed check that the correct speed variation is obtained.

For electronic type speed controls follow the installation set-up procedure provided with the control.

Switch off. If a Run-on Timer (230 RTIM) is fitted, check that the fan continues to run.

Time the run-on period, which is adjustable between 5 and 30 minutes nominal.

Timer controls are set at the works to the shortest period.

# Installation and Maintenance

## SINGLEPAK IN LINE FAN

### Dimensions

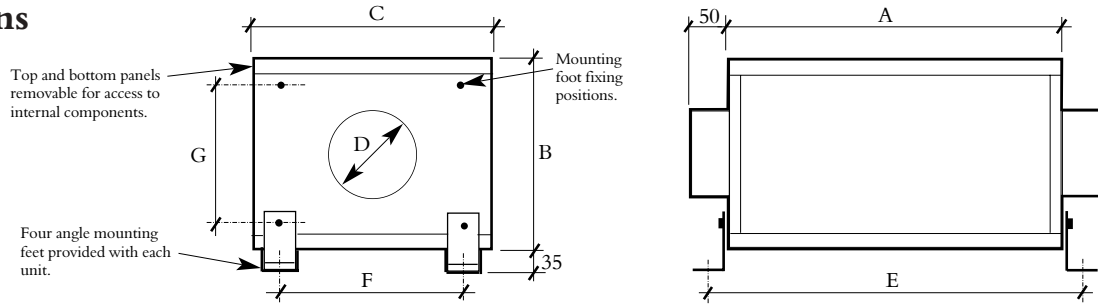

### Dimensions & Weights

Unit Code (Q) *	Case overall			Spigot	Bracket centres			Weight (kg)
	A	B	C	D dia	E	F	G	
(Q)SP125	458	231	418	125	562	372	113	11
(Q)SP200	473	296	478	200	577	432	178	19
(Q)SP200H	568	363	478	200	672	432	245	26
(Q)SP250	708	469	762	250	812	716	351	38
(Q)SP400	708	469	762	400	812	716	351	40
(Q)SP400H	708	469	762	400	812	716	351	43

### Ancillaries codes

Unit Code (Q) *	Speed ** Control Auto-trans	Speed *** Control Electronic	Matching Heater	Matching Filter	Matching Silencer	Matching Fast Clamp
(Q)SP125	SPCON2	ESC1- 3A	SH125	SF125	SIL125	FC 125
(Q)SP200	SPCON11	ESC1- 3A	SH200	SF200	SIL200	FC200
(Q)SP200H	SPCON12	ESC1- 3A	SH200	SF200	SIL200	FC200
(Q)SP250	SPCON12	ESC1- 3A	SH250	SF250	SIL250	FC250
(Q)SP400	SPCON13	ESC1- 6A	SH400	SF400	SIL400	FC400
(Q)SP400H	SPCON16	ESC1- 10A	SH400	SF400	SIL400	FC400

\* (Q) QSP = Quiet Singlepak, acoustically lined.

\* (Q) QSP = Quiet Singlepak, acoustically lined.

\*\* All Auto Transformer Speed Controls are 3 speed.

\*\*\* All Electronic Speed Controls are continuously variable.

### Silencer

Unit Code (Q) *	Matching Silencer	Spigot dia. D	X	Y	Z	Weights kg
(Q)SP125	SIL125	125	230	600	159	4.8
(Q)SP200	SIL200	200	350	600	234	8.7
(Q)SP200H	SIL200	200	350	600	234	8.7
(Q)SP250	SIL250	250	350	600	284	10.9
(Q)SP400	SIL400	400	700	900	475	30
(Q)SP400H	SIL400	400	700	900	475	30

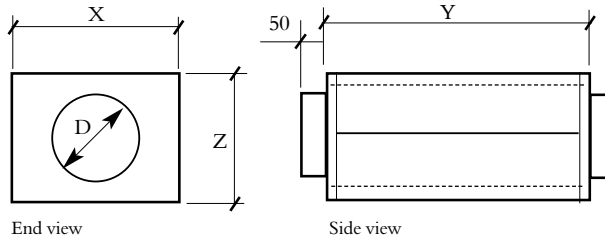

\* (Q) QSP = Quiet Singlepak, acoustically lined.

### Electric Duct Heater

Unit Code (Q) *	Matching Heater	kW	Phase	Heater Weight kg	Heater Stages	Cross sect. area C.s.a.	A		B	
							A	B	A	B
(Q)SP125	SH-125	1.0	1	3	1	0.012	125	115	125	115
(Q)SP200	SH-200	2.0	1	4	1	0.030	200	180	200	180
(Q)SP200H	SH-200	2.0	1	4	1	0.030	200	180	200	180
(Q)SP250	SH-250	3.0	1	5	1	0.050	250	180	250	180
(Q)SP400	SH-400	9.0	3	6	3	0.126	400	235	400	235
(Q)SP400H	SH-400	9.0	3	6	3	0.126	400	235	400	235

Constructed from galvanised steel. Can be installed at any angle. Terminals are provided for electrical connection. Incorporates a high temperature safety cut-out (rated 13amps). Manual reset button located on integral terminal box.

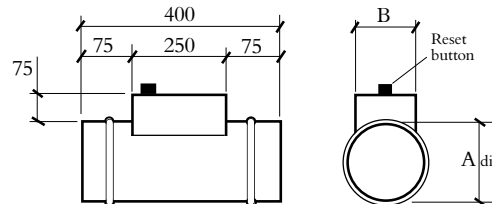

\* (Q) QSP = Quiet Singlepak, acoustically lined.

### Filter Cassette

Unit Code (Q) *	Matching Filter	A	B	C	D	C.s.a.t	Weights kg
(Q)SP125	SF125	159	230	50	125	0.09	3
(Q)SP200	SF200	234	350	50	200	0.22	4
(Q)SP200H	SF200	234	350	50	200	0.22	4
(Q)SP250	SF250	284	350	50	250	0.24	6
(Q)SP400	SF400	475	700	50	400	0.58	9
(Q)SP400H	SF400	475	700	50	400	0.58	9

Constructed from galvanised steel. Can be installed at any angle. The filter medium is non-woven synthetic fibres which are resistant to moisture, fungus, bacteria and frost. Cover retained by quick release toggle clips.

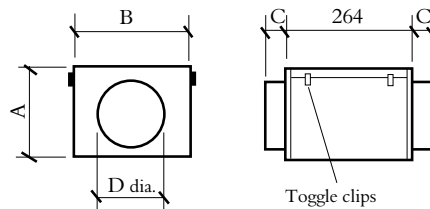

\* (Q) QSP = Quiet Singlepak, acoustically lined.  
C.s.a. t = Filter media cross sectional area (m<sup>2</sup>).

### Fast Clamp

Unit Code	Clamp code	A
(Q)SP125	FC125	125
(Q)SP200	FC200	200
(Q)SP200H	FC200	200
(Q)SP250	FC250	250
(Q)SP400	FC400	400
(Q)SP400H	FC400	400

Constructed from galvanised steel. Fitted with a gasket liner.

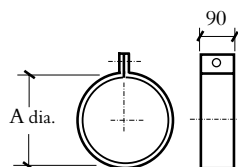

### Mounting Feet (support brackets)

4 Per kit supplied with unit

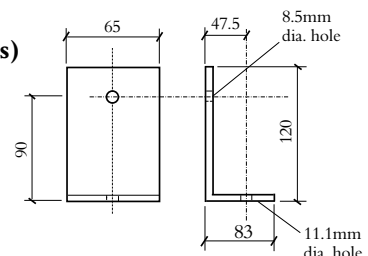

### Dimensions

### Speed Controls

#### ESC1- electronic type

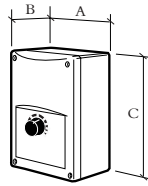

ESC1 -3A illustrated

Dims	ESC1 - 3A	ESC1 - 6A	ESC1 - 10A
A	83	115	115
B	88	95	95
C	180	195	195

#### SP CON transformer type

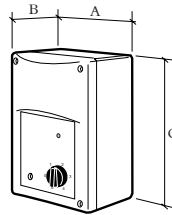

SPCON7.5 illustrated

Dims & weights	SP CON 1.5	SP CON 3.5	SP CON 7.5
A	115	200	200
B	85	140	140
C	180	280	280
kg	1.70	3.60	6.00

#### Run-on Timer (Code 230-RTIM)

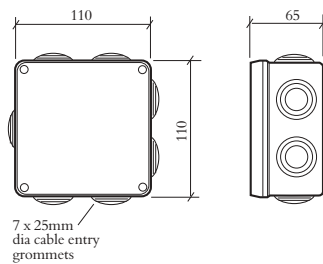

Maintains the running of the fan for a set period after the initiating circuit (coupled light switch or similar) has been disconnected. Run-on period can be adjusted between 5 and 30 minutes nominal.

#### Isolator (SWDIS-4P)

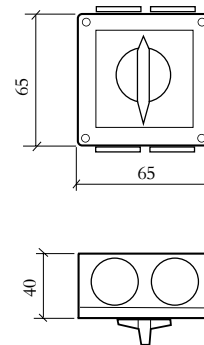

The SWDIS-4P, 4-pole off / on isolator switch can be installed on any flat surface. The base is suitable for screw fixing. Four cable knock outs are provided.

### Motor Electrical Details

Unit	Nominal Fan Speed		Motor Details			Maximum permissible temperature of air passing over motor °C
	r/s	rp	Input Power Watts	Nominal run and start currents (amps)		
				flc	sc	
SP125	34	2040	83	0.70	0.80	60
QSP125						
SP200	21	1260	97	0.58	0.80	60
QSP200						
SP200H	21	1260	229	1.56	2.30	60
QSP200H						
SP250	21	1260	325	1.63	2.30	60
QSP250						
SP400	17	1020	732	2.70	4.50	60
QSP400						
SP400H	20	1200	1225	6.00	9.60	60
QSP400H						

#### Electrical Note

(See also electrical wiring diagrams)

If a NuAire control has been supplied, wire the control to the Singlepak unit and also to the mains supply.

Refer to the diagrams when wiring to the Singlepak use the terminal block provided in the terminal box inside the casing. If a control other than NuAires' is being installed, the design of suitable circuitry is the responsibility of others.

### Unit only

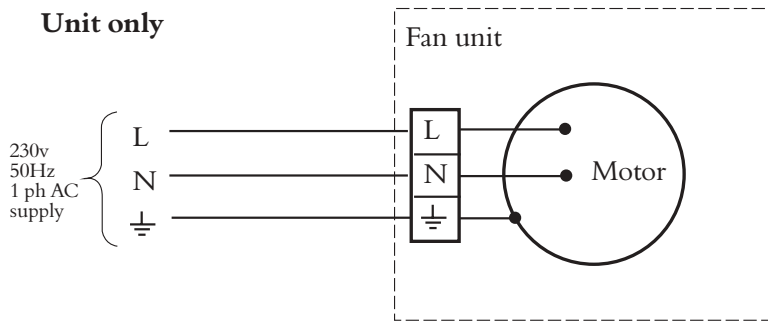

### Unit and Run on Timer

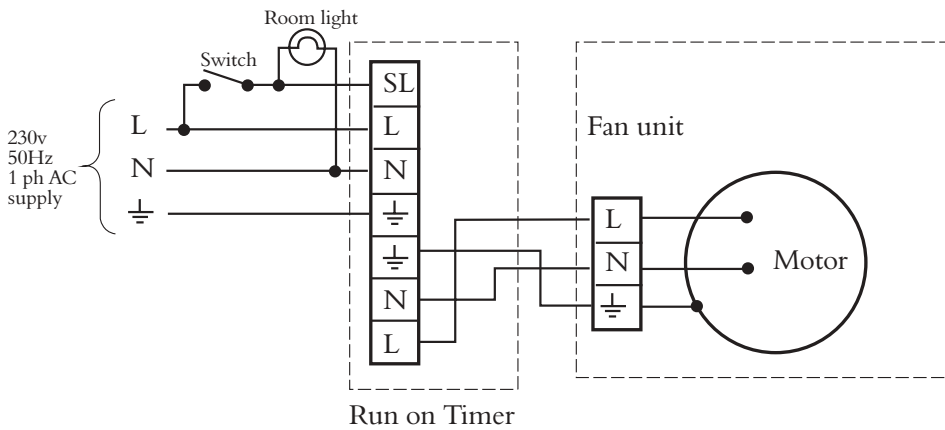

### Singlepak Heaters Single phase, single stage

(SH-100, SH-125,  
SH-200, SH-250)

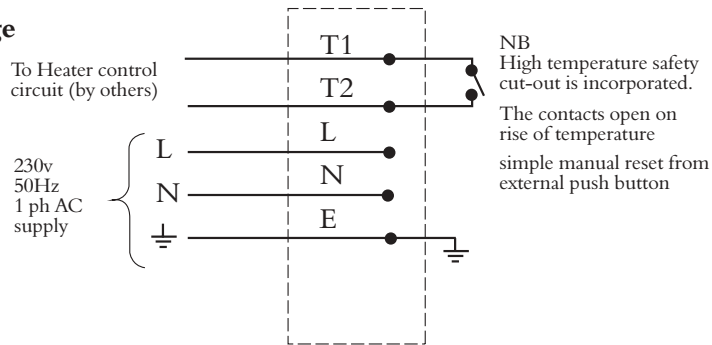

### Singlepak Heaters Three single phase stages

(SH-400)

NB  
Singlepak Heaters 3 Phase  
For 3 phase, multi-stage wiring information,  
please telephone NuAire Technical Sales  
02920 858200

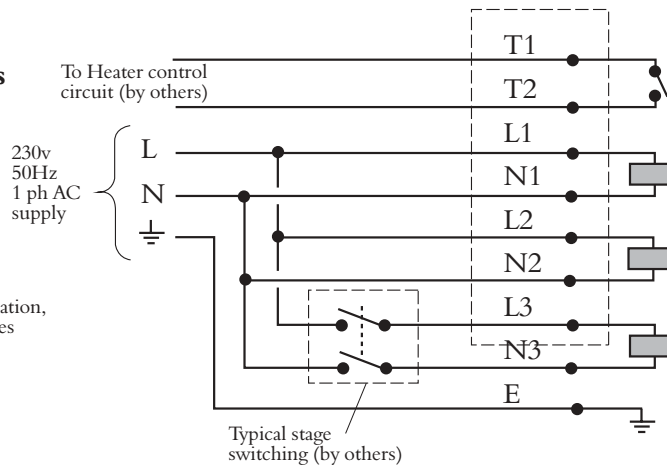

### Singlepak with Electronic speed control types:

ESC1-3A ESC1-6A ESC1-10A

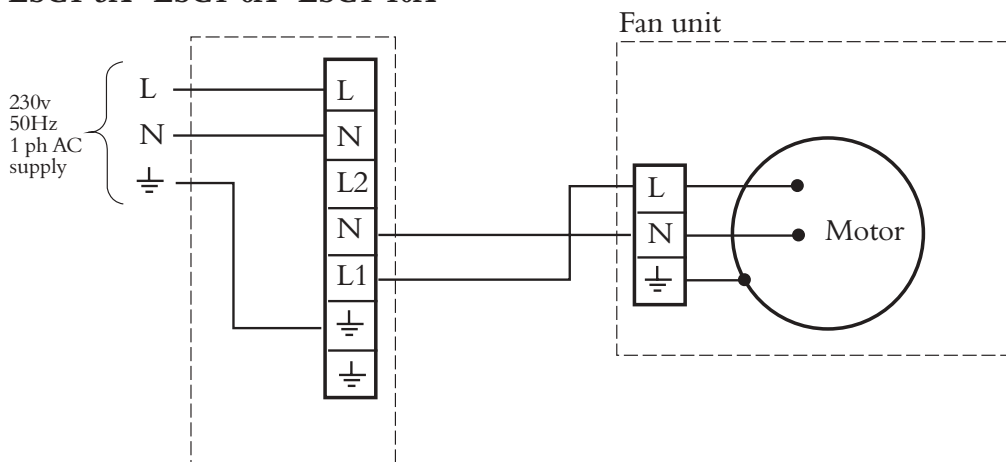

### Singlepak with Auto transformer speed control types:

SPCON-1.5 SPCON-3.5 SPCON-7.5

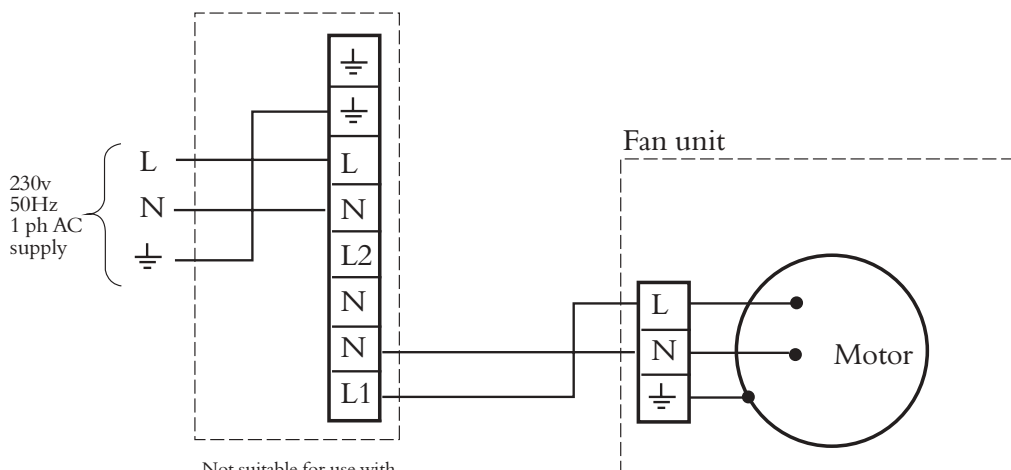

Not suitable for use with the following units:  
SP/QSP200  
SP/QSP200H  
SP/QSP250

#### Note on Speed Controls:

A list of setting instructions is supplied with each Speed Control unit.

### Maintenance

#### ISOLATION

**BEFORE COMMENCING WORK MAKE SURE THAT THE UNIT AND NUAIRE CONTROL, IF FITTED, ARE ELECTRICALLY ISOLATED FROM THE MAINS SUPPLY.**

#### Maintenance Intervals (fan unit)

The first maintenance should be carried out three months after commissioning and thereafter at twelve monthly intervals. These intervals may need to be shortened if the unit is operating in adverse environmental conditions, or in heavily polluted air.

#### Lubrication

Motors are fitted with sealed for life bearings and therefore require no further lubrication.

#### General Cleaning and Inspection (fan unit)

Clean and inspect the exterior of the Singlepak unit and associated controls etc.

Remove the access panel from the Singlepak unit. Inspect and, if necessary, clean the fan and motor assemblies and the interior of the case. If the unit is heavily soiled it may be more convenient to remove the fan / motor assemblies.

Check that the shutters are free to move smoothly and that they seal the appropriate fan outlet effectively.

Clean and inspect the fan and motor assembly as follows; taking care not to damage, distort or disturb the balance of the impeller.

- Lightly brush away dirt and dust, paying particular attention to any build up at the motor ventilating slots. If necessary, carefully remove with a blade or scraper.
- Stubborn dirt at the impeller may be carefully removed with a stiff nylon brush.
- Check all parts for security and general condition. Check that the impeller rotates freely.

Refit the assembly to the unit then replace the access covers.

#### Controls

If NuAire controls and or remote indicators are fitted, remove the covers and carefully clean out the interiors as necessary. Check for damage. Check security of components. Refit the access covers.

#### Filter Cassette

Every three months (or more frequently if operating conditions warrant) release the cover and inspect the filter. The filter element is formed over a wire mesh supporting frame and can be vacuum cleaned (preferably from the frame side). Badly soiled filters can be replaced, spares available from NuAire on request. Quote code SF followed by unit size e.g. SF250. Note: the replacement frame/filter element may need to be 'formed' to shape as the original prior to fitting.

### Replacement of Parts

The only item of the Singlepak unit likely to require replacement is the fan / motor assembly due to a failed motor or damaged impeller. In either eventuality the complete fan / motor assembly must be removed from the unit case.

#### NOTE:

**BEFORE COMMENCING WORK, ELECTRICALLY ISOLATE THE TWINPAK UNIT AND / OR THE ASSOCIATED NUAIRE CONTROL, IF FITTED, FROM THE MAINS SUPPLY.**

Remove the access cover. Disconnect the incoming wiring from the connection box (located inside case) Support the weight of the fan/motor assembly and remove the mounting screws and washers. Lift the assembly out of the case.

After replacing the faulty item, refit the fan/motor assembly and reconnect the incoming wiring to the terminal box. Replace the access cover.

#### Schedule of Parts

When ordering spares please quote the serial number of the unit together with the part number if. If the part number is not known please give a full description of the part required. The serial number will be found on the identification plate attached to the unit casing

#### Spares listing

Unit code	Blower assembly c/w motor.
(Q)SP125	771950
(Q)SP200	771954
(Q)SP200H	771955
(Q)SP250	771517
(Q)SP400	771418
(Q)SP400H	771847

### 3 YEAR WARRANTY

The three year warranty starts from the date of delivery and includes parts and labour for the first year.

The labour element is subject to full, free and safe access to the equipment as recommended by the CDM regulations.

The remaining two years covers replacement parts only.

#### NOTE:

**Installation & Maintenance of the equipment must be as directed in the instructions provided with the unit.**

### Service

As a manufacturer NuAire provides you with factory trained Service Engineers. Our Engineers are supported by a comprehensive range of spare parts 'off the shelf'.

If you are an industrial or commercial user, you may be interested in details of NuAire's regular maintenance Service Contracts.

This is a worthwhile service that helps you get the most from our products.

Our Service Department will be happy to give you more information.

**Telephone: 02920 858585**

### Controls Application Service (CAS)

A team of Engineers and technicians is available to provide pre and post order support.

We are on hand to provide help and advice from the most basic use of any NuAire equipment to the more complex applications, maximising on the versatility of our control products.

**Telephone: 029 2085 8585**

**Facsimile: 029 2085 8586**

#### NB

If you have any comments or queries on any of our products or services please write to the Product Information Manager at the main address.

# NUAIRE

## DECLARATION OF INCORPORATION & INFORMATION FOR SAFE INSTALLATION, OPERATION & MAINTENANCE

NuAire Limited,  
Western Industrial Estate, Caerphilly,  
Mid Glamorgan, CF8 1XH, United Kingdom.  
Telephone: 029 2088 5911 Fax: 029 2088 7033  
Email: info@nuaire.co.uk  
www.nuaire.co.uk

NOVEMBER 2000



**We declare that the machinery named below is intended to be assembled with other components to constitute a system of machinery. The machinery shall not be put into service until the system has been declared to be in conformity with the provisions of the EC Council Machinery Directive.**

---

<b>Designation of machinery :-</b>	SINGLE IN-LINE FAN
<b>Machinery Types :-</b>	SINGLEPAK & QUIET SINGLEPAK (SP & QSP)
<b>Relevant EC Council Directives :-</b>	98/37/EC (Machinery Directive)
<b>Applied Harmonised Standards :-</b>	EN292-1, EN292-2, EN294, EN29001
<b>Applied National Standards :-</b>	BS848 Parts One, Two and Five

---

Signature of manufacture representatives :-

Name:	Position:	Date:
1) C. Biggs 	Technical Director	3.11.00
2) W. Glover 	Manufacturing Director	3.11.00

# NUAIRE

## CE DECLARATION OF CONFORMITY

NuAire Limited,  
Western Industrial Estate, Caerphilly,  
Mid Glamorgan, CF8 1XH, United Kingdom.  
Telephone: 029 2088 5911 Fax: 029 2088 7033  
Email: info@nuaire.co.uk  
www.nuaire.co.uk

NOVEMBER 2000



**We declare that the machine named below conforms to the requirements of EC Council Directives relating to Electromagnetic Compatibility and Safety of Electrical Equipment.**

---

<b>Designation of machinery :-</b>	SINGLE IN-LINE FAN
<b>Machinery Types :-</b>	SINGLEPAK & QUIET SINGLEPAK (SP & QSP)
<b>Relevant EC Council Directives :-</b>	89/336/EEC, 92/31/EEC (EMC) 73/23/EEC, 93/68/EEC (Low Voltage Directive)
<b>Applied Harmonised Standards :-</b>	EN55014-1, EN55014-2, EN60204-1 EN60335-2-80
<b>Basis of Self Attestation :-</b>	Quality Assurance to BS EN ISO 9001 BSI Registered Firm Certificate No. FM 149

---

Signature of manufacture representatives :-

Name:	Position:	Date:
1) C. Biggs 	Technical Director	2.11.00
2) W. Glover 	Manufacturing Director	2.11.00

# **INFORMATION FOR SAFE INSTALLATION, OPERATION AND MAINTENANCE OF NUAIRE VENTILATION EQUIPMENT**

To comply with EC Council Directives 98/37/EC Machinery Directive

*To be read in conjunction with the relevant Product Documentation (see 2.1)*

## **1.0 GENERAL**

- 1.1 The equipment referred to in this **Declaration of Incorporation** is supplied by NuAire to be assembled into a ventilation system which may or may not include additional components.  
The entire system must be considered for safety purposes and it is the responsibility of the installer to ensure that all of the equipment is installed in compliance with the manufacturers recommendations and with due regard to current legislation and codes of practice.

## **2.0 INFORMATION SUPPLIED WITH THE EQUIPMENT**

- 2.1 Each item of equipment is supplied with a set of documentation which provides the information required for the safe installation and maintenance of the equipment. This may be in the form of a Data sheet and/or Installation and Maintenance instruction.
- 2.2 Each unit has a rating plate attached to its outer casing. The rating plate provides essential data relating to the equipment such as serial number, unit code and electrical data. Any further data that may be required will be found in the documentation. If any item is unclear or more information is required, please contact NuAire.
- 2.3 Where warning labels or notices are attached to the unit the instructions given must be adhered to.

## **3.0 TRANSPORTATION, HANDLING AND STORAGE**

- 3.1 Care must be taken at all times to prevent damage to the equipment. Note in particular that shock to the unit may result in the balance of the impeller being affected.
- 3.2 When handling the equipment, care should be taken with corners and edges and that the weight distribution within the unit is considered. Lifting gear such as slings or ropes must be arranged so as not to bear on the casing.
- 3.3 Equipment stored on site prior to installation should be protected from the weather and steps taken to prevent ingress of contaminants.

## **4.0 OPERATIONAL LIMITS**

- 4.1 It is important that the specified operational limits for the equipment are adhered to *e.g. operational air temperature, air borne contaminants and unit orientation.*
- 4.2 Where installation accessories are supplied with the specified equipment eg. wall mounting brackets. They are to be used to support the equipment only. Other system components must have separate provision for support.
- 4.3 Flanges and connection spigots are provided for the purpose of joining to ductwork systems. They must not be used to support the ductwork.

## **5.0 INSTALLATION REQUIREMENTS**

- In addition to the particular requirements given for the individual product, the following general requirements should be noted.*
- 5.1 Where access to any part of equipment which **moves**, or can become **electrically live** are not prevented by the equipment panels or by fixed installation detail (eg ducting), then guarding to the appropriate standard must be fitted.
- 5.2 The electrical installation of the equipment must comply with the requirements of the relevant local electrical safety regulations.

## **6.0 COMMISSIONING REQUIREMENTS**

- 6.1 General pre-commissioning checks relevant to safe operation consist of the following -  
Ensure that no foreign bodies are present within the fan or casing  
Check electrical safety. *e.g. Insulation and earthing.*  
Check guarding of system.  
Check operation of Isolators/Controls.  
Check fastenings for security.
- 6.2 Other commissioning requirements are given in the relevant product documentation.

## **7.0 OPERATIONAL REQUIREMENTS**

- 7.1 Equipment access panels must be in place at all times during operation of the unit, and must be secured with the original fastenings.
- 7.2 If failure of the equipment occurs or is suspected then it should be taken out of service until a competent person can effect repair or examination. (Note that certain ranges of equipment are designed to detect and compensate for fan failure).

## **8.0 MAINTENANCE REQUIREMENTS**

- 8.1 Specific maintenance requirements are given in the relevant product documentation.
- 8.2 It is important that the correct tools are used for the various tasks required.
- 8.3 If the access panels are to be removed for any reason the electrical supply to the unit must be isolated.
- 8.4 A minimum period of two minutes should be allowed after electrical disconnection before access panels are removed. This will allow the impeller to come to rest.  
*NB: Care should still be taken however since airflow generated at some other point in the system can cause the impeller to "windmill" even when power is not present.*
- 8.5 Care should be taken when removing and storing access panels in windy conditions.