

Twinpak In-Line Twinfan

NuAire Limited
Western Industrial Estate
Caerphilly,
Mid Glamorgan CF83 1XH
Telephone: 01222 885911
Facsimile: 01222 887033
Email: info@nuaire.co.uk

Leaflet 670526

JANUARY 1999

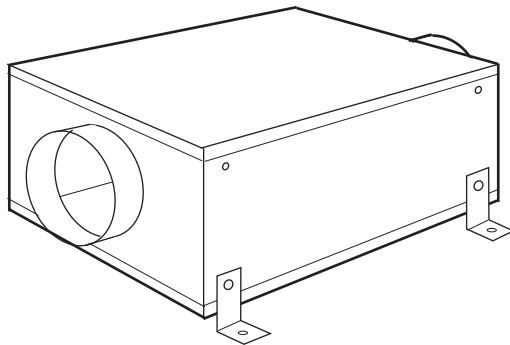

Fig. 1. General view of unit,
shown with optional mounting brackets.

Introduction

The NuAire Twinpak range consists of 10 units with duties up to a maximum of 0.92 m³/s. Units are rectangular in section and have circular rigid spigots at each end. The casing is manufactured from galvanised steel to BS 2989 1982.

Full size access panels are fitted to the top and bottom faces. These panels are fully detachable for inspection purposes.

The internal surfaces of the case (including the top and bottom panels) are lined with fire retardant acoustic material.

The fan assemblies incorporate high efficiency, forward curved centrifugal impellers running in metal scrolls. Fans discharge into a common outlet chamber through separate shutters.

Motors are manufactured to BS 5000 and are suitable for single phase supply. "Heatseeker" thermal overload protection is standard as is Class B insulation. Motor wiring terminates in connector boxes attached to the fan scrolls.

Support brackets (optional) are manufactured in galvanised steel.

A full range of matching silencers is available. See NuAire leaflet No 670527 for details.

Controls to provide a variety of options are available, including automatic change-over should the duty fan fail.

A range of 3 speed Auto Transformer and stepless Electronic Speed Controls is also available as is a Run on Timer which allows the fan to run-on for a pre-determined time after the initiating source (e.g. coupled light switch) has been disconnected. Run on period is adjustable between 5 and 30 minutes. Speed Controls and Run-on Timer Controls must be used with Auto change-over Control.

A Remote Fan Failure Indicator is also available.

Installation

Twinpak units can be mounted in any attitude except upside down or vertical with the outlet facing down. In these positions the shutters will not operate satisfactorily.

Units should always be positioned with sufficient space to allow removal of the access covers and subsequent removal of fan and motor assemblies etc.

Note: when the unit is mounted horizontally the correct orientation must be observed as indicated by direction labels on the side of the unit case.

Contents

Page

Introduction	1
Installation	1
Dimensions	2
Testing after Installation	2
Maintenance	2
Electrical	3
Replacement of parts	3
Service	3
Electrical diagrams	4

Handling

Always handle the units carefully to avoid damage and distortion. If mechanical aids are used to lift the unit, spreaders should be employed and positioned so as to prevent the slings, webbing etc. making contact with the casing.

Mounting

The method of mounting used is the total responsibility of the installer.

Note that the unit is supplied with threaded holes (M8) see fig. 1, which can be used after the removal of the rubber plugs. Support brackets (optional) can be attached at these points.

NuAire Twinfan Controls and Remote Fan Failure Indicator.

These controls may be mounted onto any firm surface using the fixing holes provided in the base. Drill and plug the mounting surface, positioning the control or indicator so that the cover screws remain accessible. This is particularly important if a battery of controls is being installed. Fix the unit using No.8 woodscrews (not supplied). For wiring purposes, the control or indicator cover has knock out slots for cable entry to suit up to 20mm conduit.

Dimensions *Fig.2. Unit dimensions. Note: Fixing points for optional support brackets shown thus ●*

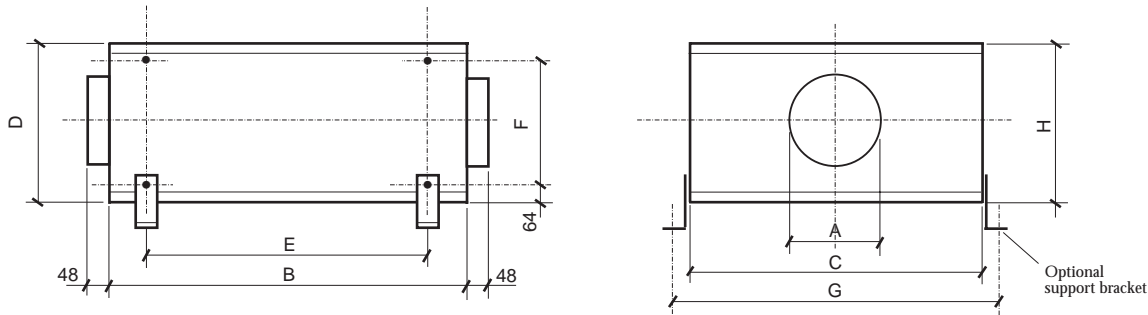

Table 1 Unit dimensions.

Unit code	Dimensions (mm)								Weight (kg)
	A	B	C	D	E	F	G	H	
GTP1	125	450	495	238	374	110	590	264	19.5
GTP2	200	465	710	303	389	175	805	329	31.9
GTPR3	200	560	710	370	484	242	805	396	43.4
GTP3	200	560	710	370	484	242	805	396	43.4
GTPR4	250	700	970	476	624	348	1065	502	57.5
GTP4	250	700	970	476	624	348	1065	502	57.5
GTPR5	400	700	970	476	624	348	1065	502	62.5
GTP5	400	700	970	476	624	348	1065	502	62.5
GTPR6	400	700	970	476	624	348	1065	502	68.5
GTP6	400	700	970	476	624	348	1065	502	68.5

Testing after Installation

Ensure that the Twinpak unit and Control / Remote Fan Failure Indicator, as relevant, are fitted.

Switch on and check that the Twinpak unit runs satisfactorily.

If a NuAire control has been installed, switch over to the standby fan by means of the control's fan selection switch.

Check that the change-over occurs.

Switch off. If a Run-on Timer (QSTIMX) is fitted, check that the fan continues to run.

Time the run-on period, which is adjustable between 5 and 30 minutes nominal.

Timer controls are set at the works to the shortest period. If a speed control is fitted, check the speed variation is obtained (3 speed auto-transformer type).

For electronic type speed controls follow the installation set-up procedure provided with the control.

Lubrication

Motors are fitted with sealed for life bearings and therefore require no further lubrication.

Maintenance

ISOLATION
BEFORE COMMENCING WORK MAKE SURE THAT THE UNIT AND NUAIRE CONTROL, IF FITTED, ARE ELECTRICALLY ISOLATED FROM THE MAINS SUPPLY.

Maintenance Intervals

The first maintenance should be carried out three months after commissioning and thereafter at twelve monthly intervals. These intervals may need to be shortened if the unit is operating in adverse environmental conditions, or in heavily polluted air.

General Cleaning and Inspection

Clean and inspect the exterior of the Twinpak unit and associated controls etc.

Remove the access panel from the Twinpak unit. Inspect and, if necessary, clean the fan and motor assemblies and the interior of the case. If the unit is heavily soiled it may be more convenient to remove the fan / motor assemblies.

Check that the shutters are free to move smoothly and that they seal the appropriate fan outlet effectively.

Clean and inspect each fan and motor assembly as follows; taking care not to damage, distort or disturb the balance of the impeller.

- Lightly brush away dirt and dust, paying particular attention to any build up at the motor ventilating slots. If necessary, carefully remove with a blade or scraper.
- Stubborn dirt at the impeller may be carefully removed with a stiff nylon brush.
- Check all parts for security and general condition. Check that the impeller rotates freely.

Refit the assemblies to the unit (see Replacement of Parts) then replace the access covers

If NuAire controls and or remote indicators are fitted, remove the covers and carefully clean out the interiors as necessary. Check for damage.

Check security of components. Refit the access covers.

Electrical Details (See table 2).

Because the run and start currents depend upon the duty and associated ductwork of an individual unit, the values quoted in the table are nominal.

Run currents will be exceeded if the Twinpak unit is operated with its cover removed. It is therefore recommended that the unit is not run for prolonged periods in this condition.

Unit code	Motor details		Input power watts	Nominal run & start currents (amps)		Maximum permissible temp. of air passing over motor °C
	Nominal Fan Speed r.p.s.	r.p.m.		f.l.c.	s.c.	
GTP1	34.0	2040	85	0.74	0.75	50 *
GTP2	22.0	1320	93	0.68	0.80	50 *
GTPR3	22.0	1320	230	1.83	2.32	50 *
GTP3	22.0	1320	230	1.83	2.32	50 *
GTPR4	19.0	1140	375	2.13	2.52	50 *
GTP4	19.0	1140	375	2.13	2.52	50 *
GTPR5	18.4	1104	650	3.63	5.21	50 *
GTP5	18.4	1104	650	3.63	5.21	50 *
GTPR6	19.5	1170	1150	5.02	10.80	50 *
GTP6	19.5	1170	1150	5.02	10.80	50 *

* 40 °C when used with speed control

Table 2 Motor electrical details.

Electrical Note

(See page 4 for electrical wiring diagrams)

If a NuAire control has been supplied, wire the control to the Twinpak unit and also to the mains supply.

Refer to page 4 when wiring to the Twinpak use the terminal blocks provided on each blower.

If a control other than NuAires' is being installed, the design of suitable circuitry is the responsibility of others.

Replacement of Parts

The only item of the Twinpak unit likely to require replacement is the fan / motor assembly due to a failed motor or damaged impeller. In either eventuality the complete fan / motor assembly must be removed from the unit case.

NOTE:

BEFORE COMMENCING WORK, ELECTRICALLY ISOLATE THE TWINPAK UNIT AND / OR THE ASSOCIATED NUAIRE CONTROL, IF FITTED, FROM THE MAINS SUPPLY.

Remove the access cover. Disconnect the incoming wiring from the connection box (located on the fan scroll) on the particular fan/motor assembly to be removed. Support the weight of the fan/motor assembly and remove the mounting screws and washers. Lift the assembly out of the case.

After replacing the faulty item, refit the fan/motor assembly and reconnect the incoming wiring to the fan mounted connection box. Replace the access cover.

Schedule of Parts

When ordering spares please quote the serial number of the unit together with the part number if. If the part number is not known please give a full description of the part required. The serial number will be found on the identification plate attached to the unit casing

Unit code	Blower assembly c/w motor.
GTP1	771270
GTP2	771271
GTPR3	771272
GTP3	771272
GTPR4	771273
GTP4	771273
GTPR5	771274
GTP5	771274
GTPR6	771275
GTP6	771275

Table 3 Spares listing

Service

As a manufacturer NuAire provides you with factory trained Service Engineers.

Our Engineers are supported by a comprehensive range of spare parts 'off the shelf'.

If you are an industrial or commercial user, you may be interested in details of NuAire's regular maintenance Service Contracts. This is a worthwhile service that helps you get the most from our products.

Our Service Department will be happy to give you more information.

Please telephone: **0222 858313**

GTPCON Auto change-over control

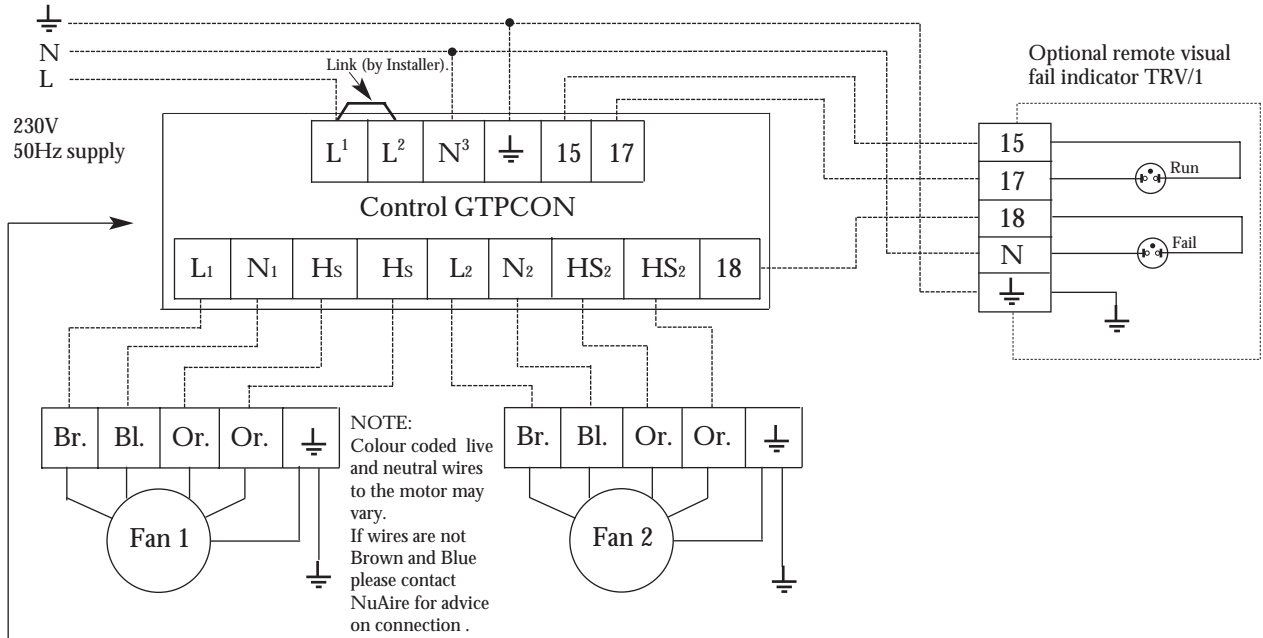

GTPCON- RFRR (Remote Fail / Remote Run indication)

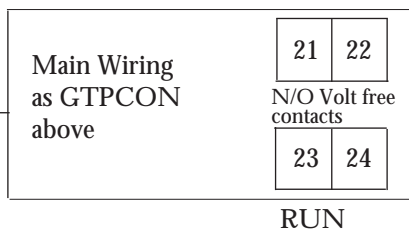

NOTE:
Volt Free Terminals 21-24 are located inside control enclosure

GTPCON with Auto transformer Speed Control

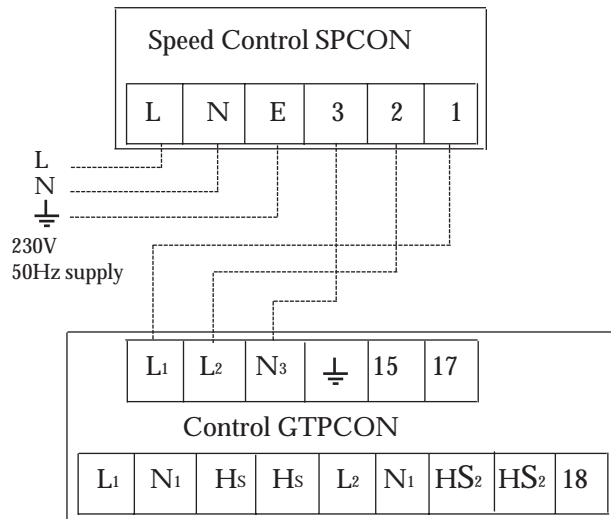

GTPCON with Run on Timer

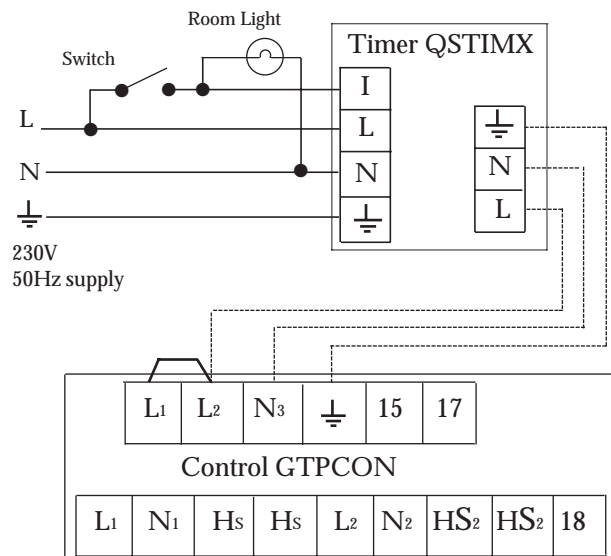

GTPCON with Electronic Speed Control.

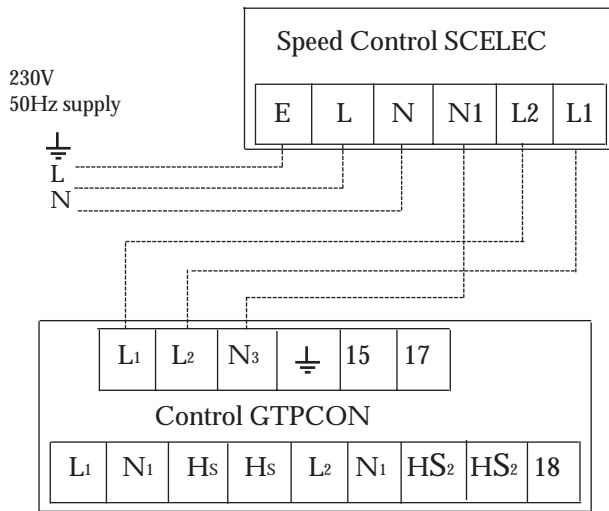

GTPCON with Electronic Speed Control & Run on Timer.

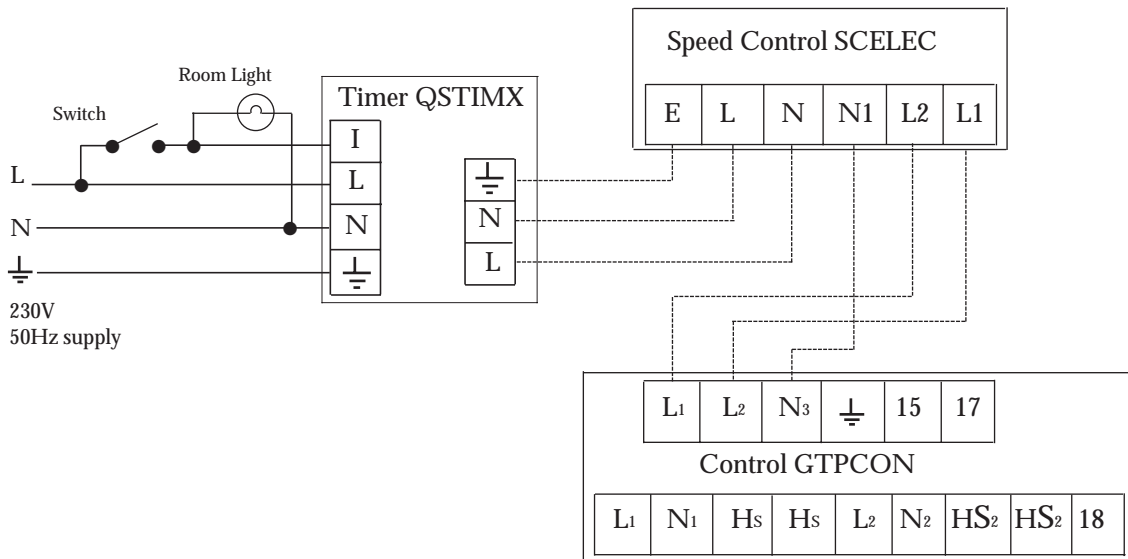

NB. connect as above for SCELEC0/1, SCELEC1/1 & SCELEC2/1. Reverse connections 4 and 5 for SCELEC3/1.

Technical or commercial considerations may, from time to time, make it necessary to alter the design, performance and dimensions of equipment and the right is reserved to make such changes without prior notice.

NUAIRE

**Western Industrial Estate,
Caerphilly, Mid Glam CF83 1XH
United Kingdom.
Telephone: 01222 885911
Facsimile: 01222 887033,
Email: info@nuaire.co.uk**

Leaflet No. 670526